



EVO Manufacturing
2014+ RAM 2500 TRACKBAR



Before starting installation procedure please read <http://evomfg.com>Returns-Warranties-Shipping>



CAREFULLY READ AND FOLLOW ALL INSTRUCTIONS IN THIS MANUAL AND KEEP FOR FUTURE REFERENCE. IF YOU HAVE ANY QUESTIONS ABOUT THE PRODUCT CALL EVO MANUFACTURING. FAILURE TO FOLLOW GUIDELINES COULD RESULT IN MALFUNCTION OF PARTS OR INJURY. PLEASE HAVE A TRAINED PROFESSIONAL ASSIST WITH OR INSTALL ALL PRODUCTS. INSTALLING EVO MFG PRODUCTS OR KITS DEMANDS SPECIFIC KNOWLEDGE, TOOLS AND EXPERIENCE. GENERAL KNOWLEDGE OF HOW TO USE LATER SPECIFIED TOOLS AND/OR LIMITED EXPERIENCE WITH EVO MFG PRODUCTS MAY NOT BE ENOUGH TO PROPERLY COMPLETE THESE TASKS. SOME OF EVO MFG PRODUCTS MAY REQUIRE TWO OR MORE PEOPLE TO INSTALL SAFELY AND CORRECTLY. DO NOT ATTEMPT ALONE, ALWAYS ENLIST THE HELP OF TRAINED PROFESSIONAL WHEN NEEDED.

Notes: Set Up Before installation

These instructions involve how to install a Trackbar.

This installation process may vary.

Some adjustments may be needed to secure liner properly per individual vehicle setup.

Keep all mounting bolts loose (installed but not torqued) we will torque later at the end of complete installation

READ BEFORE INSTALL:

It is generally a good idea to apply Loctite to all threaded bolts.

ALWAYS wear safety glasses and other approved safety gear when working on a vehicle.

All supplied bolts torqued according to chart at end of instruction.

It is recommended all installation be performed by a trained professional. Some modification may have to be done.

Paint all unfinished surfaces after install is complete if preferred.



Product Prt. #	Description	#	Part #	Quantity
EVO-905B	RAM 2500 Trackbar Welded Black, with Uniball	1	EVO-12605BB	1
	RAM 2500 Thread End Trackbar Zinc with Bushing	2	EVO-12606CZBB	1
	M10 Flange Bolt Yellow	3	EVO-900477	2
	M10 Ny Insert Flange Nut Yellow	4	EVO-900478	2
	RAM 2500 Trackbar Unibal Bearing Spacers, Stainless Steel	5	EVO-20050	2

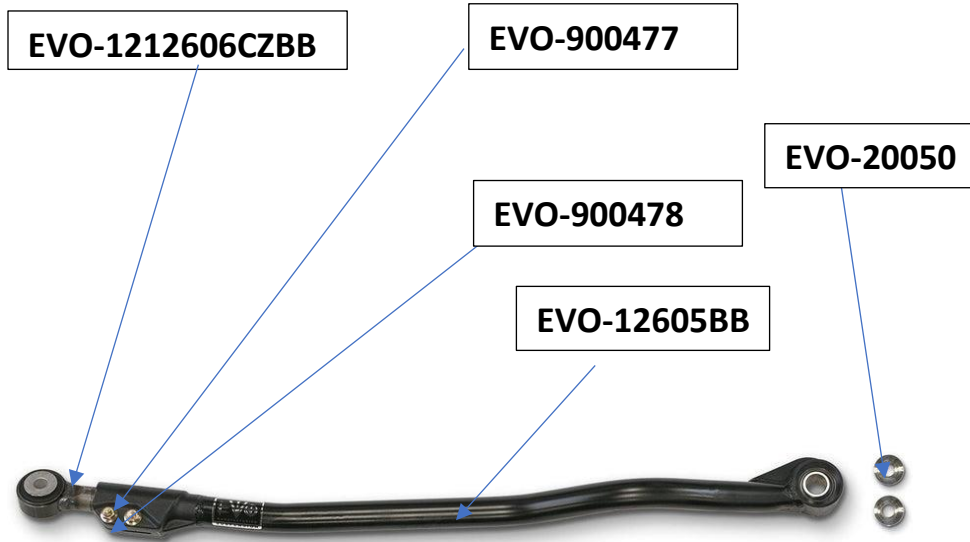



Recommended Tools:

- Wrench with standard sockets 12 Point
 - Grinder
 - Paint
 - Impact Driver
 - Torque
 - Paint
 - Talent
-



Safety Steps for installation

- For installing EVO MFG products always use wheel chokes to block rear tires from rolling.
 - Always make sure you have everything necessary ready before install.
 - If you have to, carefully lift front of vehicle by front frame rails extending suspension until tires leave the ground, place frame on approved jack stands for vehicle. Verify all lines/wires are not over extended.
 - Remove tires if needed for easier install.
 - Make sure to wear safety equipment (eye protection, hand protection, foot protection etc.) at all times during installation.
 - Make sure all safety precautions have been taken.
 - Always check and replace any part of vehicle that is worn or broken before starting install.
 - Do not mix anything EVO with weaker alternatives.
 - It is generally a good idea to apply liquid threadlock to all bolts.
 - Tighten included hardware to torque specifications in bottom table unless it is otherwise specified, factory bolts should be torqued to factory Jeep specifications.
-





INSTALL

Pictures are for reference only, product may vary.

SAFELY PARK VEHICLE ON LEVEL GROUND AND CHALK WHEELS

Remove Factory bolts at Front Trackbar, both ends to remove trackbar from vehicle

IMPORTANT:

1. With grinder or similar. Clearance factory coil mount at passenger side of axle as shown below. Clearance needs to be made for ample clearance with larger aftermarket trackbar end through cycle of suspension.

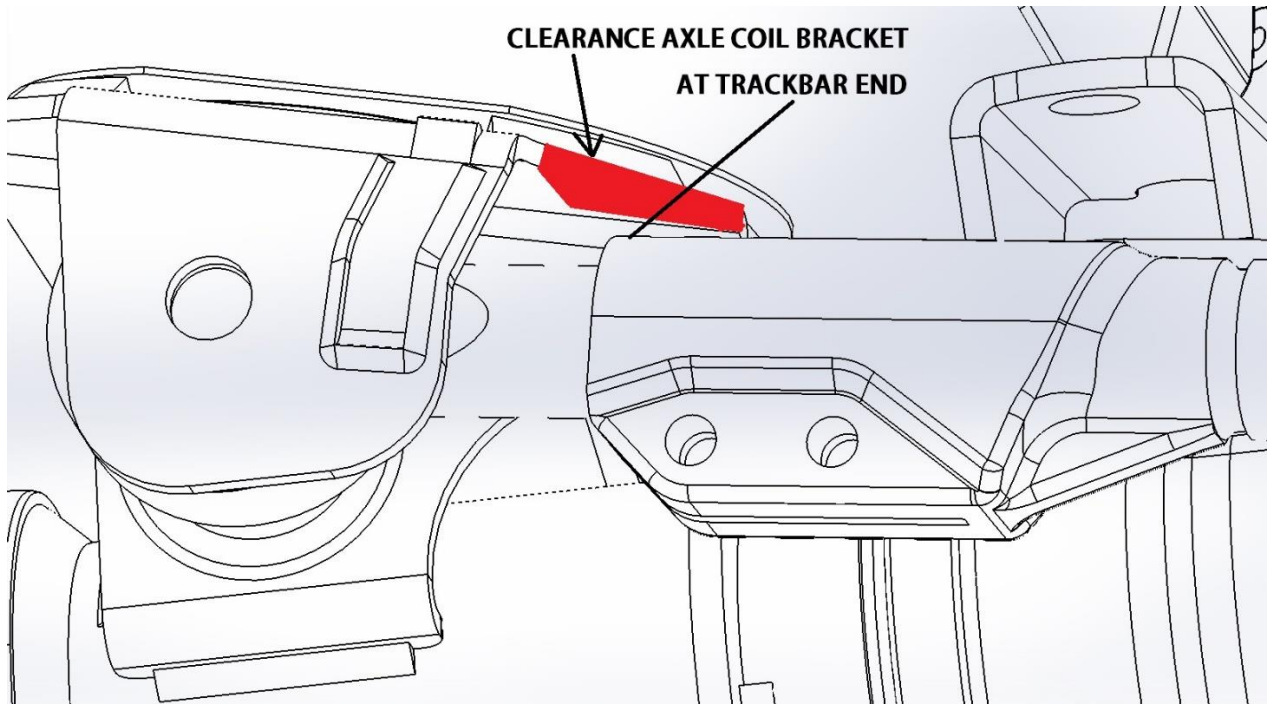

2. Once verified sufficient clearance has been made. Paint all exposed metal.



3. Adjustable EVO Adjustable Trackbar length. Approximate Starting Length.
 - Distance from Center to center of bolt locations should be approximately 39.25"
-

4. Install EVO Trackbar into factory location using the factory hardware. Loosely install bolts at this time.
Welded end should install at frame, adjustable end should install at axle, Clamp/bolts on downside.

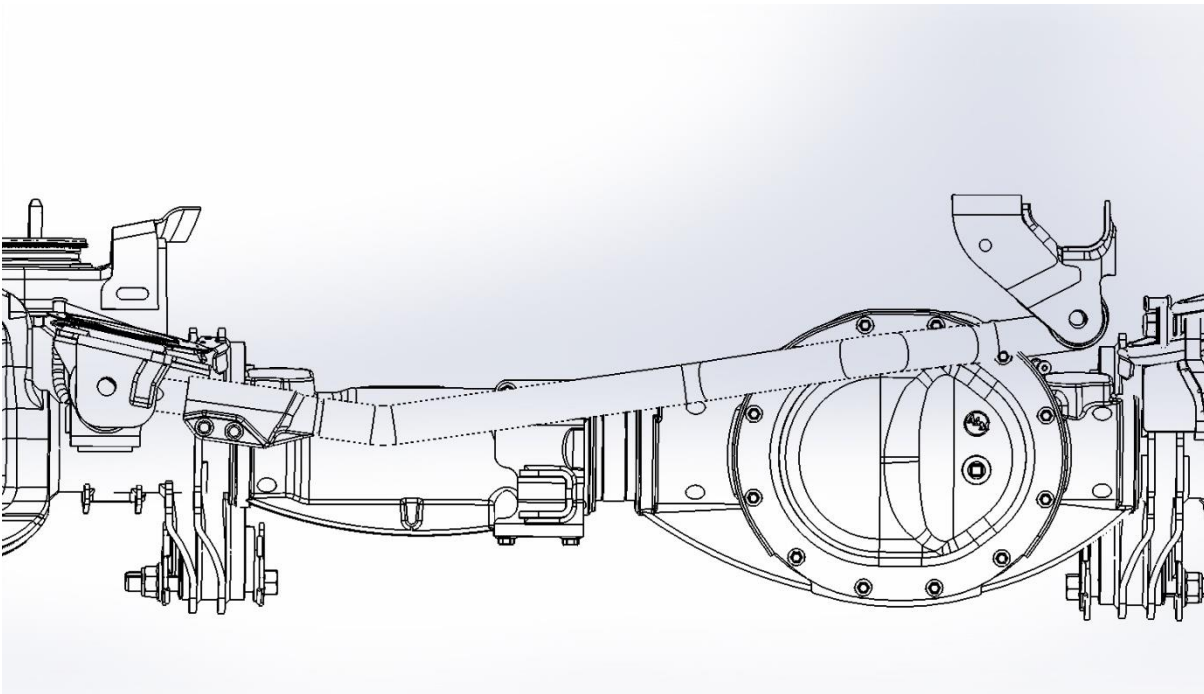

5. Verify axle center at ride height. Adjust as needed to center.
Once centered: Torque both pinch bolts #3/4 on trackbar in an alternating pattern until both pinch bolts reach 45 FT/LB.
-

6. At Ride Height. Torque Factory frame and axle bolts to 200 Ft/Lbs.
-



After Install:

- Tighten all bolts securing purchased parts to specified locations.
- After completing installation using provided instructions, go through all steps again to make sure nothing was missed, not tightened or improperly assembled.
- Some components may need to be purchased separately.
- Check turn signals, headlights, fog lights (if applicable), taillights, blinkers and windshield wipers.
- Adjust mirrors, speedometer and headlights if needed.
- Make sure all gauges are fully operational.
- Drive the vehicle slowly for a couple minutes, looking and listening for abnormal noises while driving. After modification of a vehicle there will be differences in driving experiences and capabilities, be mindful of that.
- Inspect and Retorque all Bolts after 500 miles of completed installation and regularly thereafter.
- Some modification may be required.

Standard Torque Specs:

Size	Grade 2		Grade 5		Grade 8		18-8 S/S	
	Coarse	Fine	Coarse	Fine	Coarse	Fine	Coarse	Fine
#4*	-	-	-	-	-	-	5.2	-
#6*	-	-	-	-	-	-	9.6	-
#8*	-	-	-	-	-	-	19.8	-
#10*	-	-	-	-	-	-	22.8	31.7
1/4	4	4.7	6.3	7.3	9	10	6.3	7.8
5/16	8	9	13	14	18	20	11	11.8
3/8	15	17	23	26	33	37	20	22
7/16	24	27	37	41	52	58	31	33
1/2	37	41	57	64	80	90	43	45
9/16	53	59	82	91	115	129	57	63
5/8	73	83	112	128	159	180	93	104
3/4	125	138	200	223	282	315	128	124
7/8	129	144	322	355	454	501	194	193
1†	188	210	483	541	682	764	287	289