



EVO Manufacturing

Jeep Wrangler JLU 2018+

JL Unlimited Trail Roof Rack

EVO-3038, EVO-3038B kits





Before starting installation procedure please read <http://evomfg.com>Returns-Warranties-Shipping>

**CAREFULLY READ AND FOLLOW ALL INSTRUCTIONS IN THIS MANUAL AND KEEP FOR FUTURE REFERENCE. IF YOU HAVE ANY QUESTIONS ABOUT THE PRODUCT CALL EVO MANUFACTURING. FAILURE TO FOLLOW GUIDELINES COULD RESULT IN MALFUNCTION OF PARTS OR INJURY. PLEASE HAVE A TRAINED PROFESSIONAL ASSIST WITH OR INSTALL ALL PRODUCTS. INSTALLING EVO MFG PRODUCTS OR KITS DEMANDS SPECIFIC KNOWLEDGE, TOOLS AND EXPERIENCE. GENERAL KNOWLEDGE OF HOW TO USE LATER SPECIFIED TOOLS AND/OR LIMITED EXPERIENCE WITH EVO MFG PRODUCTS MAY NOT BE ENOUGH TO PROPERLY COMPLETE THESE TASKS. SOME OF EVO MFG PRODUCTS MAY REQUIRE TWO OR MORE PEOPLE TO INSTALL SAFELY AND CORRECTLY. DO NOT ATTEMPT ALONE, ALWAYS ENLIST THE HELP OF TRAINED PROFESSIONAL WHEN NEEDED.**

**Notes: Set Up Before installation**

**Make sure to start with the standard unmodified hard top.**

**Clean hard top and make sure water gutter is clean and clear of any debris.**

**Keep all mounting bolts loose (installed but not torqued) we will torque later at the end of complete installation**

**READ BEFORE INSTALL:**

It is generally a good idea to apply Loctite to all threaded bolts.

ALWAYS wear safety glasses and other approved safety gear when working on a vehicle.

All supplied bolts torqued according to chart at end of instruction.

It is recommended all installation be performed by a trained professional. Some modification may have to be done.

This rack has a distributed dynamic load rating of 70kg / 154lbs. Applying a bead of RTV Silicone in drip rail before inserting rack rails is advised for higher loads/speeds. It is advised to not carry items at high speeds that can create lift (upward force due to wind) such as but not limited to kayaks and surfboards etc.



Parts included: Table below shows black (painted) trail roof rack.

| Description                  | # | Part #     | Quantity |
|------------------------------|---|------------|----------|
| Lower T Slats                | 1 | EVO-12366B | 8        |
| Front Plate                  | 2 | EVO-12365B | 1        |
| Passenger Side Main Plate    | 3 | EVO-12363B | 1        |
| Driver Side Main Plate       | 4 | EVO-12362B | 1        |
| Rear Plate                   | 5 | EVO-12364B | 1        |
| Upper L Slat                 | 6 | EVO-12367B | 5        |
| Outer Mount Bracket Assembly | 7 | EVO-12368B | 4        |
| Inner/Upper Main Mount       | 7 | EVO-12369B | 4        |
| Inner Bolt Tab               | 7 | EVO-12370B | 4        |
| Heavy Duty Rubber Trim       | 8 | 900432     | 2        |
| Upper Lip Rubber Trim        | 8 | 900433     | 4        |
| Hardware Bag                 | 9 | 770085     | 1        |

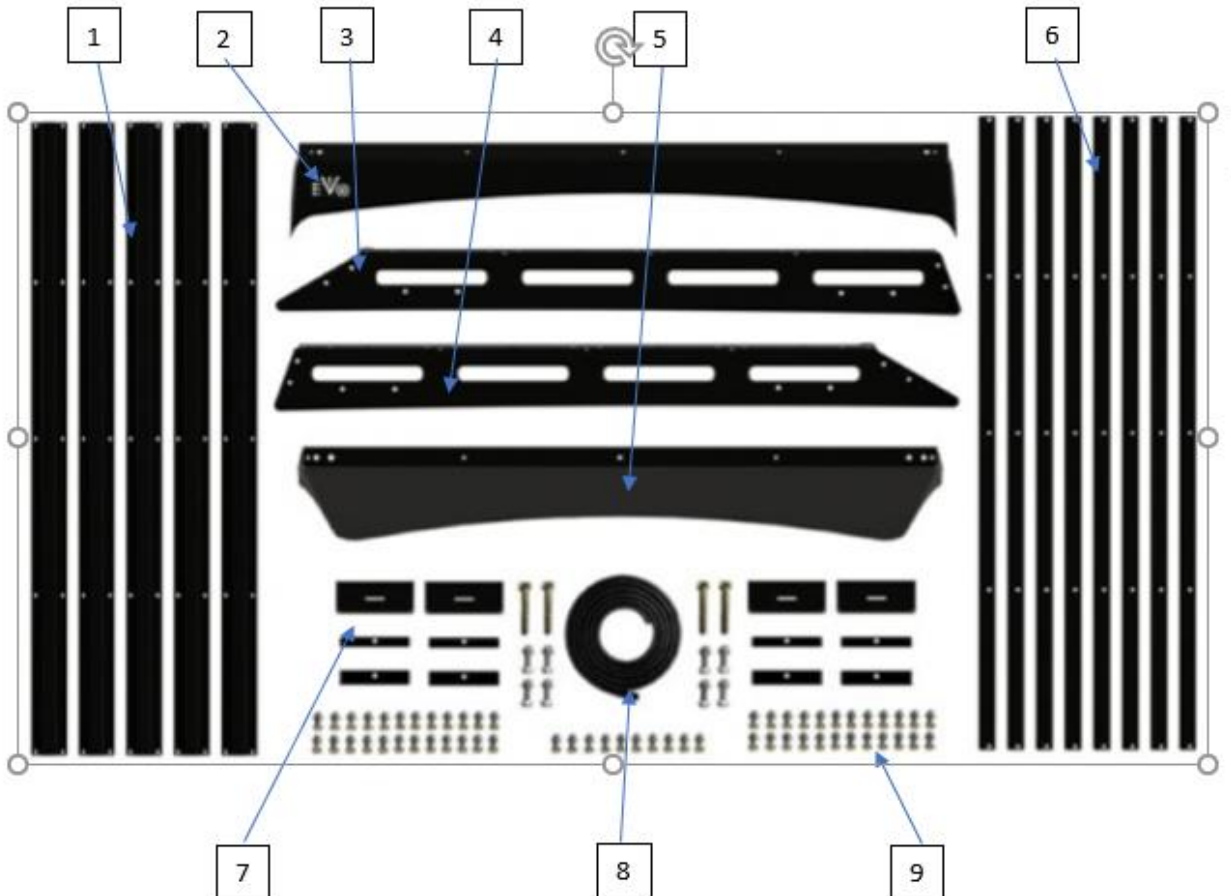



#### Recommended Tools:

- Nutsert tool (5/6-18)
  - Loctite
  - Rubber Mallet
  - Allen Keys
- 



#### Safety Steps for installation

- For installing EVO MFG products always use wheel chokes to block rear tires from rolling.
  - Always make sure you have everything necessary ready before install.
  - If you have to, carefully lift front of vehicle by front frame rails extending suspension until tires leave the ground, place frame on approved jack stands for vehicle. Verify all lines/wires are not over extended.
  - Remove tires if needed for easier install.
  - Make sure to wear safety equipment (eye protection, hand protection, foot protection etc.) at all times during installation.
  - Make sure all safety precautions have been taken.
  - Always check and replace any part of vehicle that is worn or broken before starting install.
  - Do not mix anything EVO with weaker alternatives.
  - It is generally a good idea to apply liquid threadlock to all bolts.
  - Tighten included hardware to torque specifications in bottom table unless it is otherwise specified, factory bolts should be torqued to factory Jeep specifications.
- 





## **FRONT INSTALL**

1. Begin by assembling the 3 inner slat assemblies. Each will consist of 2 "L" Slat pieces and 1 "T" slat pieces.
2. Using supplied  $\frac{1}{4}$ " bolt, washer and flange nuts, assemble 3 sets of inner slat assemblies by installing 6 bolts on the 6 inner holes of each. The end 2 holes on each end of each slat assembly should remain without bolts at this time.

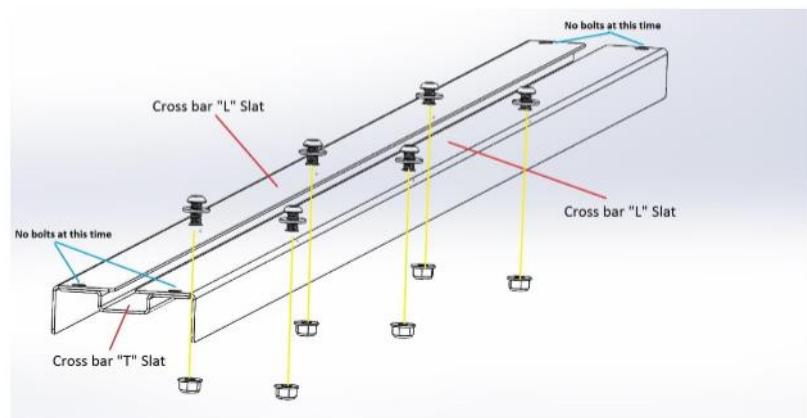

**Tighten bolts of all 3 assemblies.**

3. Assemble the front and rear slat assemblies next. These will consist of 1 "L" Slat piece and 1 "T" flat piece.

4. Using supplied 1/4" bolt, washer and flange nuts, assemble 2 sets of end (front and rear) slat assemblies by installing bolts on the 3 inner holes only. The end 2 holes and other middle 3 holes should remain without bolts at this time.

5. Tighten 3 bolts on both front and rear assemblies. Front and rear assemblies are duplicates of each other.

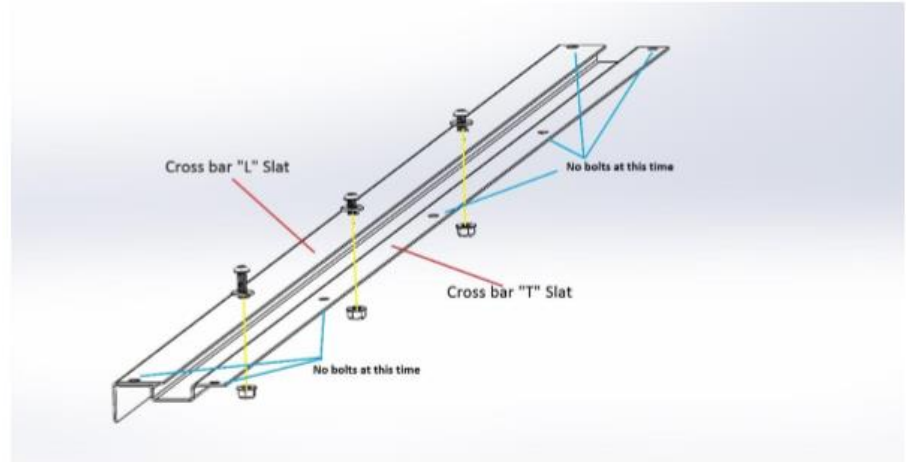

**On a flat surface**

6. Loosely assemble the perimeter sections of the rack. This consists of the Driver side plate, Passenger side plate, Front plate and Rear plate.

Using the supplied 1/4" bolts, washer and flange nut loosely install 2 sets at each corner.

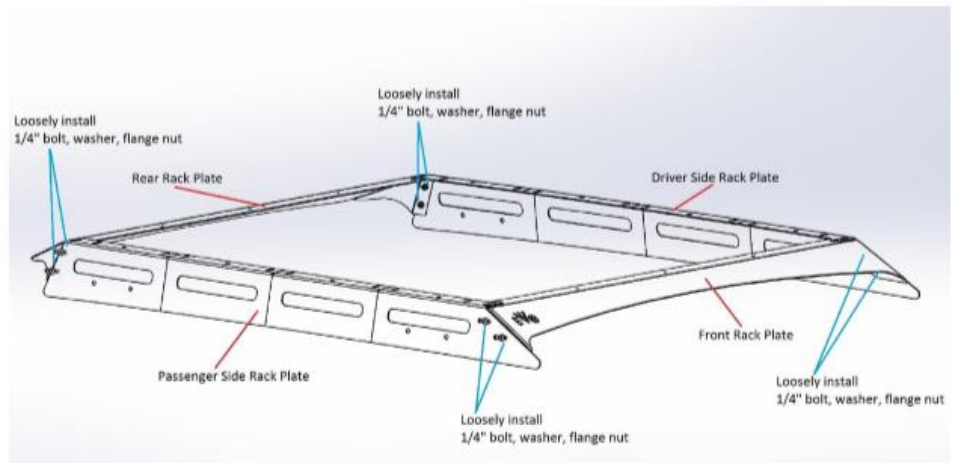

8. Using supplied  $\frac{1}{4}$ " bolt, washer and flange nuts, loosely install the 3 pre-assembled middle cross bar slats, front and rear cross bar slat.

All cross bar assemblies should be installed on the underside of the perimeter parts.

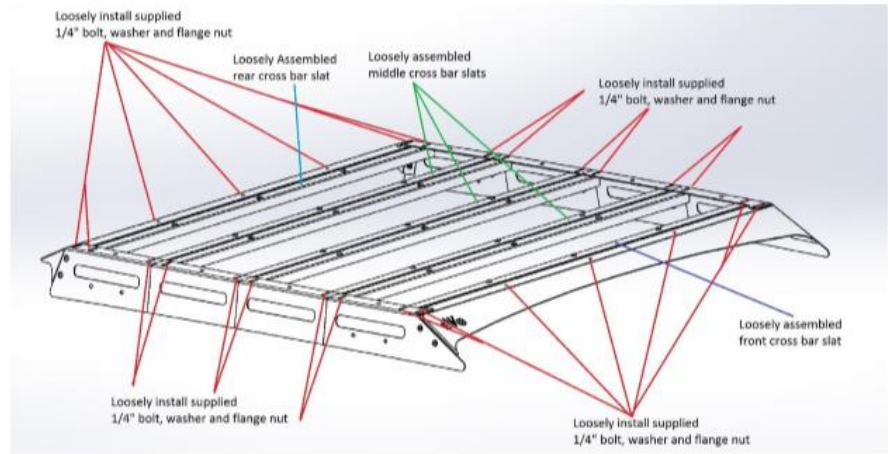

10. Using supplied  $\frac{5}{16}$ " bolt, washer, flange nut. Install upper bolt plate and lower bolt plate as shown. Install upper bolt plate from inside of main plate through slot toward the outside. Tighten bolts. Do this at all 4 ends.

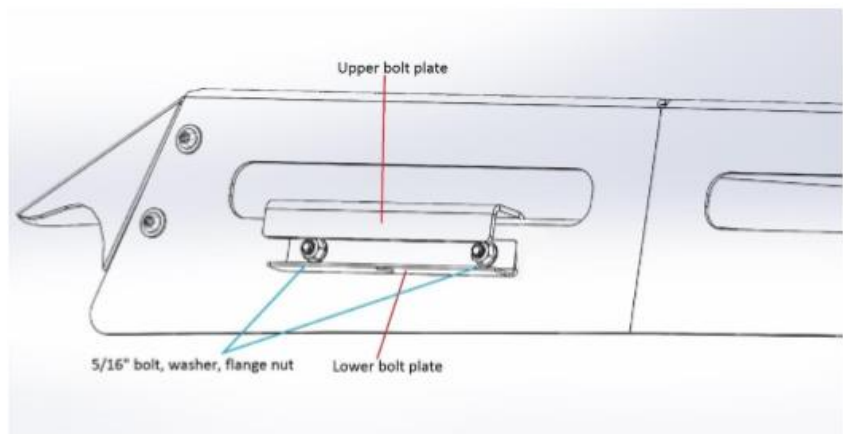

11. Install edge trimming on the edge of the 4 outer rail mounting plate lips.
- 



1. Using your nutsert installation tool and tool specific installation guide, install nutserts onto the outer rail mounting plate. Use picture as reference.
- 





**Upper bolt plate should be installed to the inside of main side plate and pass through large slot. See picture to the right**

---



**This may require 2 or more people.**

12. With rack loosely assembled and upside down. Flip over if needed. Install/press on edge trim on driver side plate edge end to end. Trim and use remainder to repeat on passenger side plate.
13. Flip rack with top up. Lift over jeep hard top and set into place on into the drip rail. Rack should be placed where the rear edge of the side plates line up with the rear of the drip rail. Use line on picture as reference.

**The rack may require a slight push to fully seat into drip rail.**

---





14. Insert bolt and washer from top down of upper mounting plate and thread into outer rail mount. Lower edge with trim should be grabbing underside of hardtop drip rail.

**Note:** Do not over tighten this bolt. Snug to 15 lb/ft. Repeat on all 4 mounting ends.

---



15. Tighten all bolts.

---





**After Install:**

- Tighten all bolts securing purchased parts to specified locations.
- After completing installation using provided instructions, go through all steps again to make sure nothing was missed, not tightened or improperly assembled.
- Some components may need to be purchased separately.
- Check turn signals, headlights, fog lights (if applicable), taillights, blinkers and windshield wipers.
- Adjust mirrors, speedometer and headlights if needed.
- Make sure all gauges are fully operational.
- Drive the vehicle slowly for a couple minutes, looking and listening for abnormal noises while driving. After modification of a vehicle there will be differences in driving experiences and capabilities, be mindful of that.
- Inspect and Retorque all Bolts after 500 miles of completed installation and regularly thereafter.
- Some modification may be required.

**Recommended Torque:**

| Size        | Grade 2 |      | Grade 5 |      | Grade 8 |      | 18-8 S/S |      |
|-------------|---------|------|---------|------|---------|------|----------|------|
|             | Coarse  | Fine | Coarse  | Fine | Coarse  | Fine | Coarse   | Fine |
| <b>#4*</b>  | -       | -    | -       | -    | -       | -    | 5.2      | -    |
| <b>#6*</b>  | -       | -    | -       | -    | -       | -    | 9.6      | -    |
| <b>#8*</b>  | -       | -    | -       | -    | -       | -    | 19.8     | -    |
| <b>#10*</b> | -       | -    | -       | -    | -       | -    | 22.8     | 31.7 |
| <b>1/4</b>  | 4       | 4.7  | 6.3     | 7.3  | 9       | 10   | 6.3      | 7.8  |
| <b>5/16</b> | 8       | 9    | 13      | 14   | 18      | 20   | 11       | 11.8 |
| <b>3/8</b>  | 15      | 17   | 23      | 26   | 33      | 37   | 20       | 22   |
| <b>7/16</b> | 24      | 27   | 37      | 41   | 52      | 58   | 31       | 33   |
| <b>1/2</b>  | 37      | 41   | 57      | 64   | 80      | 90   | 43       | 45   |
| <b>9/16</b> | 53      | 59   | 82      | 91   | 115     | 129  | 57       | 63   |
| <b>5/8</b>  | 73      | 83   | 112     | 128  | 159     | 180  | 93       | 104  |
| <b>3/4</b>  | 125     | 138  | 200     | 223  | 282     | 315  | 128      | 124  |
| <b>7/8</b>  | 129     | 144  | 322     | 355  | 454     | 501  | 194      | 193  |
| <b>1+</b>   | 188     | 210  | 483     | 541  | 682     | 764  | 287      | 289  |