

TRIM AREA

N 37° R.19



TRIM AREA

N 37° R.19





EVO Manufacturing

Jeep Wrangler JL/JT Gladiator

JL/JT Control Arms

EVO- 3082B, 3081B, 3007B, 3006B, 1175B, 1174B





Before starting installation procedure please read <http://evomfg.com>Returns-Warranties-Shipping>

**CAREFULLY READ AND FOLLOW ALL INSTRUCTIONS IN THIS MANUAL AND KEEP FOR FUTURE REFERENCE. IF YOU HAVE ANY QUESTIONS ABOUT THE PRODUCT CALL EVO MANUFACTURING. FAILURE TO FOLLOW GUIDELINES COULD RESULT IN MALFUNCTION OF PARTS OR INJURY. PLEASE HAVE A TRAINED PROFESSIONAL ASSIST WITH OR INSTALL ALL PRODUCTS. INSTALLING EVO MFG PRODUCTS OR KITS DEMANDS SPECIFIC KNOWLEDGE, TOOLS AND EXPERIENCE. GENERAL KNOWLEDGE OF HOW TO USE LATER SPECIFIED TOOLS AND/OR LIMITED EXPERIENCE WITH EVO MFG PRODUCTS MAY NOT BE ENOUGH TO PROPERLY COMPLETE THESE TASKS. SOME OF EVO MFG PRODUCTS MAY REQUIRE TWO OR MORE PEOPLE TO INSTALL SAFELY AND CORRECTLY. DO NOT ATTEMPT ALONE, ALWAYS ENLIST THE HELP OF TRAINED PROFESSIONAL WHEN NEEDED.**

**Notes: Set Up Before installation**

**This is a general instruction for this component kit.**

**Directions/pictures may vary for each specific install, use for reference only.**

**Keep all mounting bolts loose (installed but not torqued) we will torque later at the end of complete installation**

**Do not remove more than two control arms at a time**

**FRONT LOWER JL ENFORCER ARM STARTING LEGNTH CENTER TO CENTER, 24 1/8"**

**FRONT UPPER JL ENFORCER ARM STARTING LEGNTH CENTER TO CENTER, 20 1/4"**

**REAR LOWER JL ENFORCER ARM STARTING LEGNTH CENTER TO CENTER, 19 3/4"**

**REAR UPPER JL ENFORCER ARM STARTING LEGNTH CENTER TO CENTER, 17 1/2"**

**READ BEFORE INSTALL:**

ALL measurements stated above are starting points only, every vehicle is different. Professional alignment is recommended.

It is generally a good idea to apply Loctite to all threaded bolts.

ALWAYS wear safety glasses and other approved safety gear when working on a vehicle.

All supplied bolts torqued according to chart at end of instruction.

It is recommended all installation be performed by a trained professional. Some modification may have to be done.

Paint all unfinished surfaces after install is complete.



Parts included: Table below shows JL/JT Control Arms.

Description	#	Part #	Quantity
Jl Rear Lower Adj Control Arms	1	1174B	2
JL Rear Upper Adj Control Arms	2	1175B	2
JL/JT Front Lower Control Arms	3	3006B	2
JL/JT Front Upper Control Arms	4	3007B	2
JT Rear Adj Upper Control Arms	5	3081B	2
JT Rear Adj Lower Control Arms	6	3082B	2

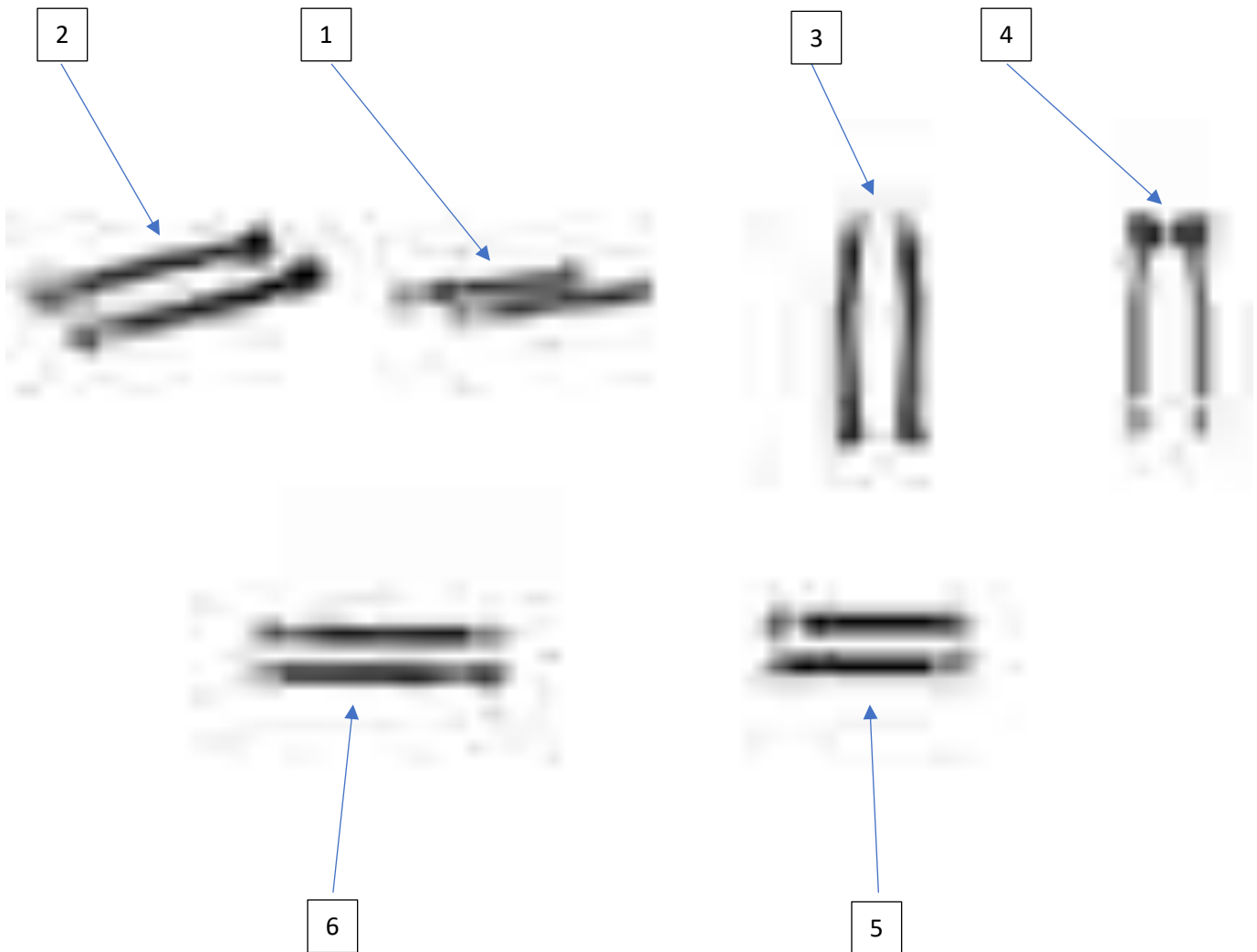



#### **Recommended Tools:**

- Standard socket set w/ wrench
  - OR Standard wrench set
- 



#### **Safety Steps for installation**

- For installing EVO MFG products always use wheel chokes to block rear tires from rolling.
  - Always make sure you have everything necessary ready before install.
  - If you have to, carefully lift front of vehicle by front frame rails extending suspension until tires leave the ground, place frame on approved jack stands for vehicle. Verify all lines/wires are not over extended.
  - Remove tires if needed for easier install.
  - Make sure to wear safety equipment (eye protection, hand protection, foot protection etc.) at all times during installation.
  - Make sure all safety precautions have been taken.
  - Always check and replace any part of vehicle that is worn or broken before starting install.
  - Do not mix anything EVO with weaker alternatives.
  - It is generally a good idea to apply liquid threadlock to all bolts.
  - Tighten included hardware to torque specifications in bottom table unless it is otherwise specified, factory bolts should be torqued to factory Jeep specifications.
- 





**After alignment is complete and no additional adjustments are to be made to control arms. Torque all 1" Jam Nuts to 250 ft/lbs and all 1-1/4" Jam Nuts torque to 300 ft/lbs. Regularly check all jam nuts and punch bolts on all control arms for proper torque/tightness. Failure to do so may cause premature wear of threads on arms.**

For front upper control arms:

1. Disconnect push-in clip from front upper control arm mounts at axle holding wire.

For all other arms:

2. Remove and replace one arm at a time. Keep bolts loose (installed but un-torqued) as described above. We will torque later in the installation process.

Use pictures as reference.



3. Make sure zerk fittings are facing up and at adjustable end at axle.
4. Adjustable end of control arms should be on the axle side.
5. Reuse factory hardware to mount EVO MFG control arms.

Note: For front upper control arms, bend in arm should face down.

Use pictures as reference.





Set pinion angle on vehicle so that the driveshaft and the pinion are inline with the axle at an approximate right height and centered to vehicle.

---



---

After Install:

- Tighten all bolts securing purchased parts to specified locations.
- After completing installation using provided instructions, go through all steps again to make sure nothing was missed, not tightened or improperly assembled.
- Some components may need to be purchased separately.
- Check turn signals, headlights, fog lights (if applicable), taillights, blinkers and windshield wipers.
- Adjust mirrors, speedometer and headlights if needed.
- Make sure all gauges are fully operational.
- Drive the vehicle slowly for a couple minutes, looking and listening for abnormal noises while driving. After modification of a vehicle there will be differences in driving experiences and capabilities, be mindful of that.
- Inspect and Retorque all Bolts after 500 miles of completed installation and regularly thereafter.
- Some modification may be required.





Recommended Torque:

Size	Grade 2		Grade 5		Grade 8		18-8 S/S	
	Coarse	Fine	Coarse	Fine	Coarse	Fine	Coarse	Fine
<b>#4*</b>	-	-	-	-	-	-	5.2	-
<b>#6*</b>	-	-	-	-	-	-	9.6	-
<b>#8*</b>	-	-	-	-	-	-	19.8	-
<b>#10*</b>	-	-	-	-	-	-	22.8	31.7
<b>1/4</b>	4	4.7	6.3	7.3	9	10	6.3	7.8
<b>5/16</b>	8	9	13	14	18	20	11	11.8
<b>3/8</b>	15	17	23	26	33	37	20	22
<b>7/16</b>	24	27	37	41	52	58	31	33
<b>1/2</b>	37	41	57	64	80	90	43	45
<b>9/16</b>	53	59	82	91	115	129	57	63
<b>5/8</b>	73	83	112	128	159	180	93	104
<b>3/4</b>	125	138	200	223	282	315	128	124
<b>7/8</b>	129	144	322	355	454	501	194	193
<b>1†</b>	188	210	483	541	682	764	287	289



**EVO-201-1**

**EVO Enforcer PRO Stage 1**



<u>QTY</u>	<u>PART #</u>	<u>DESCRIPTION</u>
☐ 1	EVO-11022B	EVO Front Lower Control Arm, Driver
☐ 1	EVO-11023B	EVO Front Lower Control Arm, Pass
☐ 1	EVO-11042B	REARWARD BRACKET JK FRONT TRACKBAR BRACKET
☐ 1	EVO-11043B	JK FRONT TRACKBAR BRACKET, BLACK
☐ 1	EVO-11044B	DRIVER SIDE SWAYBAR LINK BRACKET, BLACK
☐ 1	EVO-600089	DRAG LINK RHD JK
☐ 1	EVO-20022CZ	JK STEERING FLIP ADAPTOR
☐ 1	EVO-770027	EVO FRONT JK TRACKBAR BRACKET HARDWARE PACK
☐ 1	EVO-11090B	Driver Shock Mount Tower
☐ 1	EVO-11091B	Pass Shock Mount Tower
☐ 1	EVO-11092B	Pass Lower B/O C/O Mount
☐ 1	EVO-11092DB	Driver Lower B/O C/O Mount
☐ 2	EVO-12022CZ	LWR Res Mount
☐ 2	EVO-12023CZ	Drill Plate B/O C/O Clear Zinc
☐ 1	EVO-600067	Brakeline Pack
☐ 1	EVO-770041	F/ Bolt-On Coilover Hardware Pack
☐ 2	EVO-20005	3" Front Bumpstop Spacer
☐ 2	EVO-900333	Thread Cutting Screw for Metal/ Plastic
☐ 4	EVO-20032	Swaybar Bushing Tube
☐ 4	EVO-600077	Bushing
☐ 2	EVO-12029B	Front B/O C/O 14 1/2" Swaybar Link
☐ 1	EVO-770008	Shock Mounting Hardware Pack
☐ 2	EVO-20031	BOC Spacer Tube
☐ 4	EVO-900257	SAE 40 Worm Drive Hose Clamp
☐ 1	EVO-12025B	Rear DRVR Mount Bolt On Coilover
☐ 1	EVO-12026B	Rear PASS Mount Bolt On Coilover
☐ 1	EVO-10041B	DRVR Rockstar Skid
☐ 1	EVO-10040B	PASS Rockstar Skid
☐ 1	EVO-12028B	RCC Trackbar Bracket
☐ 1	EVO-7700021	RCC Trackbar Bracket HARDWARE Pack
☐ 1	EVO-600067	Brakeline Pack

1. Park vehicle on level ground.
2. Elevate front of vehicle securely and safely until tires leave ground.
3. Safely and securely support front frame of vehicle on adjustable jack stands
4. Remove front wheels/tires
5. Remove front swaybar links from vehicle
6. Remove brakeline mounting bolt at frame on both driver and passenger side. Do not disassemble brakeline itself.
7. Remove front shocks
8. Remove front springs
9. Working on the driver side first, remove factory lower front control arm
10. Install Supplied EVO Front lower control arm on driver side with zerk fitting on both ends facing upwards. The arms should bend towards the inside of the vehicle with the clamping tubes at the axle end facing upwards. Starting length of control arms from center of hole to center of hole at the joints should be 22 7/8". This is a recommended starting length and will change after a professional alignment has been performed. Adjusting control arm length should be made using the OnVehicle adjuster starting with the joint and adjuster threaded completely in.
11. Torque both bolts to factory specifications
12. Repeat previous steps on passenger side.
13. On both driver and passenger side, drill and 5/16" hole in the center of the spring mount on axle.
14. Using supplied self threading bolt, place the bumpstop extensions over the drilled hole on the axle and thread through the center the self threading bolt on both driver and passenger sides
15. Remove bolt at trackbar on passenger side at axle
16. Remove swaybar links from axle mounts.

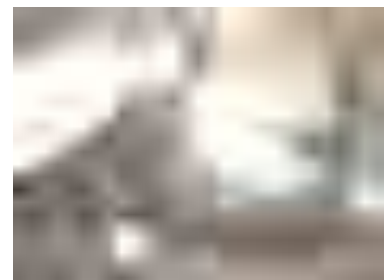
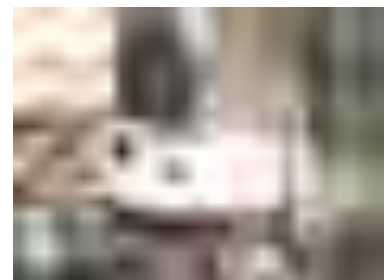

17. Place the smaller supplied bracket into the axle trackbar mount
18. Using the supplied 9/16 bolt, washer and nut and smaller length 5/16 bolt washer and nuts, loosely bolt into place. Do not fully tighten.

19. Place the larger supplied trackbar bracket onto the axle mount on the outside.

20. Using the supplied 9/16 bolt, washer and nut and smaller length 5/16 bolts washer and nuts, loosely bolt into place. Do not fully tighten.

21. Insert the shorter 1/2" bolt with washers and nut for the side bolting the two pieces together.

22. Insert the u-bolt around the axle tube through the mount on the new supplied brackets. Use the supplied 3/8" Locknuts. Make sure to not over tighten.

23. Insert the longer 1/2" bolt with washers and nut through the factory swaybar tab first, then through the supplied trackbar brackets.

24. Tighten all supplied bolts to torque specs at end of these instructions.

25. Remove nut at draglink/steering knuckle connection. Remove Draglink from steering knuckle. This may require you to hit steering knuckle where draglink mounts with small sledge hammer.

26. Remove draglink from factory coupler up towards the pitman arm. You do not want to remove the joint at the pitman arm, just the bar from the coupler. Leave all other components installed as from the factory.

27. With a 13/16" drill bit, drill straight down through factory knuckle where draglink stud was previously mounted. Be as careful as possible to drill straight through knuckle.

28. Using supplied crush sleeve, insert from top down into newly drilled hole in knuckle

29. Using the supplied draglink, thread into coupler at pitman arm end.

30. Insert the new draglink from the top down through the newly installed crush sleeve at the steering knuckle.

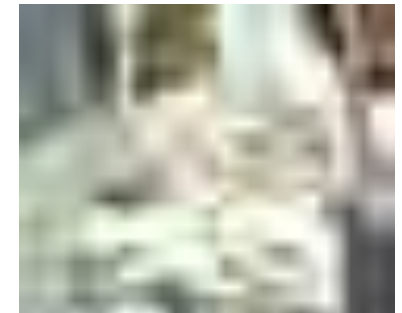
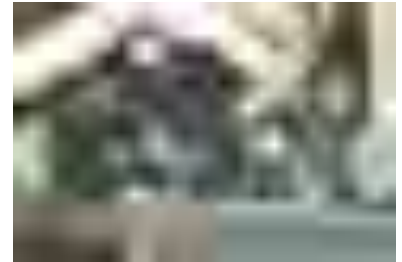

31. Using the factory nut removed from the factory draglink, install on to newly installed draglink. Use of a thread locking compound is recommended.

32. On driver side, hold up the swaybar extension tab to factory swaybar tab on the inside of factory swaybar tab.

33. With bolt holes at the swaybar tab lined up. Mark the hole that needs to be drill into the coil pocket.

34. With a 5/16" drill bit, drill marked hole into coil pocket. This may require the removal of your brake rotor on the driver side depending on your drilling equipment. If removed, follow factory specifications when removing and reinstalling.

35. With the supplied longer 1/2" bolt, washers and nut, bolt supplied bracket on the inside of the factory bracket.

36. Using the supplied longer 5/16" bolt, washers and nut bolt the supplied bracket to the coil spring mount. This will require the use of the supplied thick spacer tube between the supplied bracket and the coil mount.

37. Reinstall the trackbar to its new higher location with factory hardware

38. Reinstall swaybar endlinks at their new higher location with factory hardware.

39. Torque all supplied bolts to torque specs and the end of these instructions.

40. Torque all factory bolts to factory specifications.

41. Reinstall wheels and torque to factory specifications.

42. Carefully lower vehicle back to ground.

43. Retorque all bolts after first 500 miles and every off road use.

44. Insert front plate over factory bump stop. Align at top with existing hole and centered around bump stop. Mark two holes to be drilled.

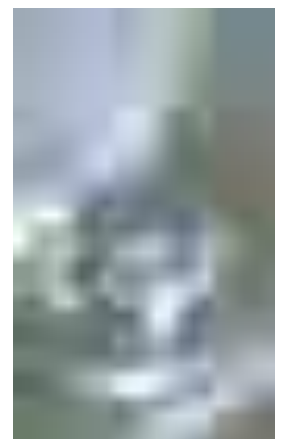
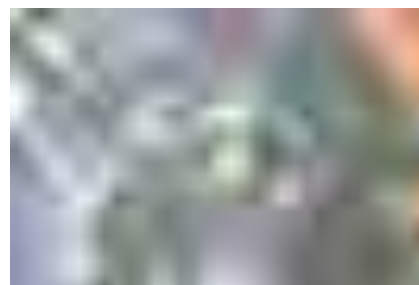

45. Drill marked holes with 7/16" drill
46. Place front coilover tower over upper front bump stop tube.
47. Rotate reward until contact with plastic wheel well. Note where tower makes contact.
48. Make sure all wires and hoses are out of way.
49. Using a grinder, slowly cut away plastic ribs, test tower and repeat. This will take a few iterations of testing, marking and cutting to clean away the plastic. Only the ribs need to be removed. Continue until tower seats onto top of factory spring perch and shock mount. Install hardware.
50. Cut lower axle shock mount as shown. This is to give clearance for coilover
51. Install lower axle bracket on the outside (tire side) of factory shock mount.
52. Holes on underside of factory shock mount and side of spring mount may need to be enlarged with drill. Passenger side will need one hole drilled completely.
53. Install EVO lower shock mount with 3/8" hardware on the underside of current shock mount and 5/16" of side of spring mount
54. Remove brake lines.
55. Install new supplied longer brake line and washers to factory hard-line and caliper
56. Install new mounting bracket at frame stacking EVO lower reservoir mount on outside of brake line bracket using factory bolt. Align as shown.

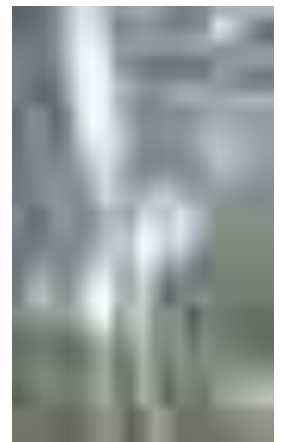
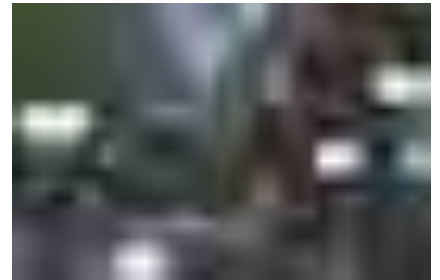

57. Install front coilover where fitting at top of coilover is directed toward rear of JK. Use supplied 1/2" hardware and shock spacers both top and bottom mounts



58. On both driver and passenger side, drill a 5/16" hole in the center of the spring mount on axle.

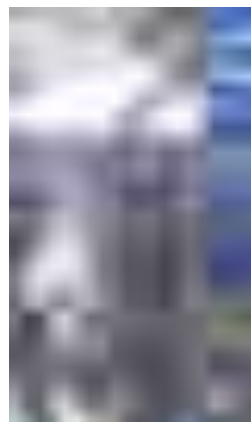

59. Using supplied self threading bolt, place the bump stop extensions over the drilled hole on the axle and thread through the center with supplied self threading bolt on both driver and passenger sides. Press down on bolt firmly while threading.
60. Twist and raise reservoir and place in mount behind rear of upper coilover tower.
61. Using supplied hose clamps mount to both upper and lower mounts.



62. Assemble front swaybar endlinks.  
Tap hourglass into endlink ends with mallet. Insert sleeve into center of hourglasses.



63. Install, outside of swaybar, inside of axle mount.

64. Install wheels/tires.

65. Carefully cycle suspension, turning wheels left and right as you go up and down to make sure you have clearance.

66. Follow factory procedures on bleeding brakes.

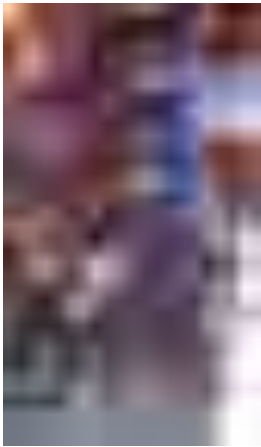

67. Turn spanner nut on top of coil spring, compressing the spring until the distance of the threaded portion between the shock end cap and the spanner is approximately 1.25". This is a starting point. This will vary on a lot of factors (added weight). Screw down if you want more lift, screw up for less. Added vehicle weight will make this vary.

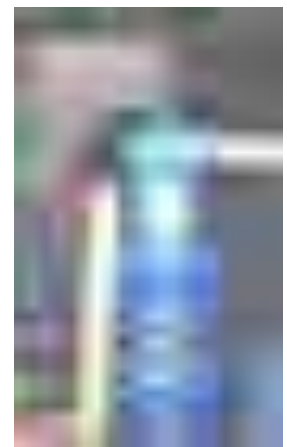

68. Carefully remove jack stands and lower to ground

69. Torque wheels to factory or aftermarket specifications.

70. Set vehicle onto ground. Move vehicle forward and backwards a few feet each way while turning wheel to right and left to settle vehicle.

71. Verify desired ride height. If ride height is undesirable, carefully lift front of vehicle by frame until wheels are off the ground. Turn spanner up to lower ride height, down to raise ride height.

72. Repeat previous steps until desired ride height is achieved

73. Torque all supplied bolts to chart below. All factory bolts to factory specifications. Clean and verify no fluid leaks at Brakelines after brake application.

74. Elevate rear of vehicle securely

75. Remove rear wheels

76. Secure frame with adjustable jack stands

77. Remove rear sway bar end links

78. Remove rear shocks

79. Remove rear springs and parking brake cable bracket from under body

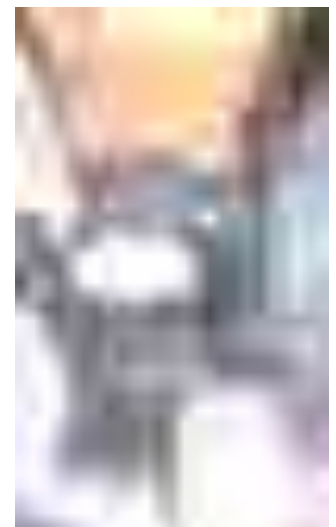
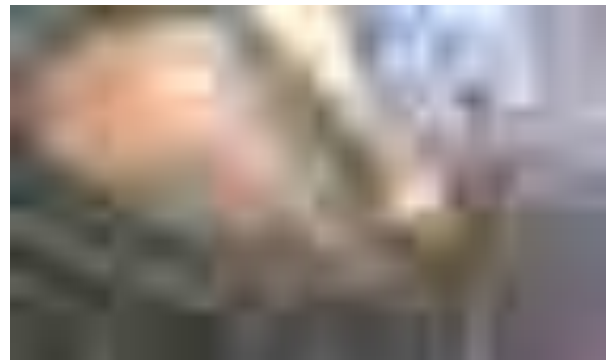



80. Using 15mm wrench, loosen small nuts on body mounts of JK from the middle of the JK to the rear. 2007-2011 JKs will have 3 sets of body mounts on both sides of frame. 2012+ will have 2 sets.

81. On driver side. Remove bolt between frame and body that holds gas filler tube to the body.

82. Remove muffler from vehicle. Loosen clamp just in front of axle on the exhaust. Spray lubricant on rubber hangers, pry hangers from frame.

83. On passenger side rear exhaust hanger at frame. Bend hanger upwards about  $\frac{3}{4}$ " with pry bar.

84. Using a jack, carefully apply pressure to rear tube lifting rear of body from frame. There needs to be about a  $\frac{1}{2}$ " gap between body and frame.

85. With rear body lifted from frame. On both driver and passenger side, insert rear upper strengthening bracket above original shock mount. If difficult to insert. Raise

body more. On 2007-2011 JKs the front section of the bracket (2 slotted holes) needs to be inserted under the body mount flange. OR remove these two body mounts.

86. After strengthening bracket is inserted. Lower Jack, tighten all body mount bolts.

87. Remove driver rear lower control arm bolt at axle.

88. With a paint pen, mark 1.5" down from center of lower control arm hole in the factory axle bracket

89. Carefully, with a Cutoff Wheel/Reciprocating Saw, cut along line, all the way around the control arm pocket and factory swaybar tab.

90. Sand remaining shock tabs, swaybar tab and cut surface smooth

91. Paint all exposed metal surfaces

92. Install driver Rock Star as seen in the photo

93. Install the  $\frac{3}{8}$ " bolts, washers on both sides and lock nuts into the rear two holes on the driver side control arm bracket. The lower  $\frac{3}{8}$ " bolt should be inserted from front to rear. The upper  $\frac{3}{8}$ " should be inserted from the rear to the front.

94. Reinsert lower control arm into the axle mounting brackets

95. Using the factory bolt, reinsert into factory hole with Rock Star brackets in place through control arm

96. Tighten  $\frac{3}{8}$ " hardware to 40 ft-lbs

97. Repeat previous Rockstar steps on passenger side

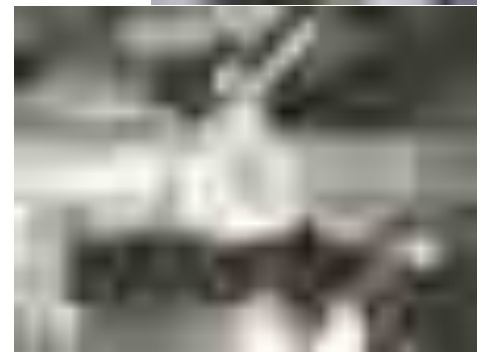
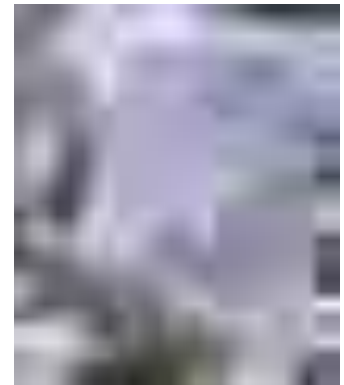
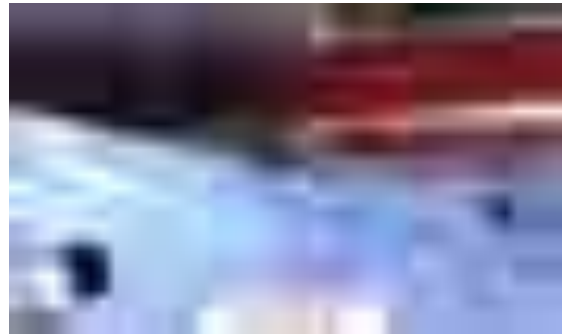

98. Remove rear trackbar bolt at axle, leave trackbar bolt at frame installed  
99. Cut factory rear trackbar bracket at axle as shown. Only remove the rear most part of the bracket. Sand all cuts smooth with flat mounting plate. Install rear trackbar bracket as shown with supplied 9/16 bolt and u-bolts. Recommended: Weld on rear trackbar bracket to axle where ever possible. Reinstall trackbar into new higher location with factory bolt. (torque to factory specifications once vehicle is on ground and at ride height.)

100. Install bumpstop extension to axle. Upper pad should be angled forward of axle. Use supplied 5/16" hardware.

101. Assemble upper shock bracket to coilover as shown. Add 1/2" washers to both sides of shock. This will help prevent shock rotation. Reservoir should be angled to middle of JK on both pass and driver sides.

102. Thread two mounting bolts into stock threaded frame bolts. This needs to be done in iterations. Walk the bracket up by threading one bolt a few turns then the other and continue until fully seated. Bolts need to go through 2 holes in the EVO upper strengthening brackets.

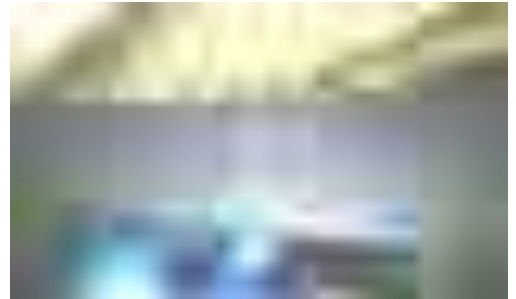
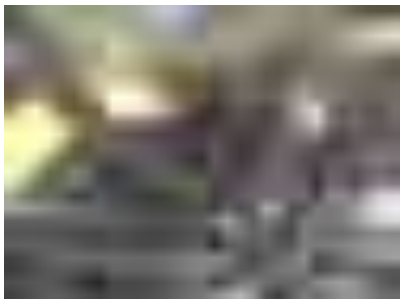
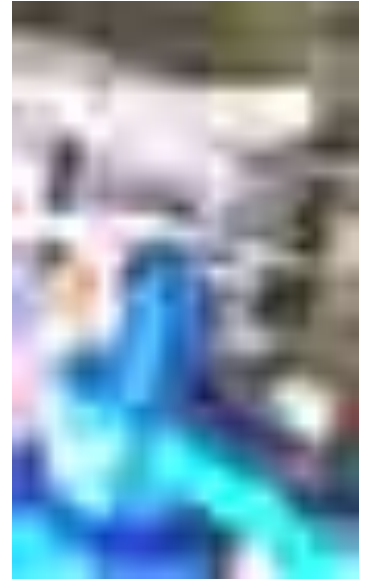

Install the supplied M10 nuts and washers to the shock bolts above the EVO strengthening plate.

103. On frame side, just below exhaust hangers, drill hole through frame with 1/2" drill bit.

104. Install supplied 1/2" bolt

105. Install lower shock mounts to EVO Rockstars using supplied silver spacers, one on each side of shock. Remove spacers if any are installed on the lower end of the shocks. Use supplied M12 bolt.

106. Remove Factory Swaybar from frame.

107. Install EVO MFG Rear Swaybar Relocation Spacers which relocates the OE swaybar back approximately 1". Use the 20MM Black Hex bolts included in the

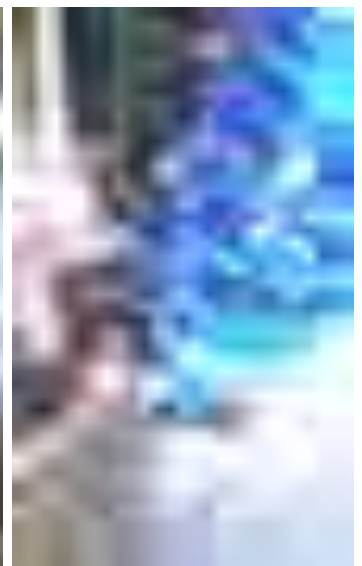
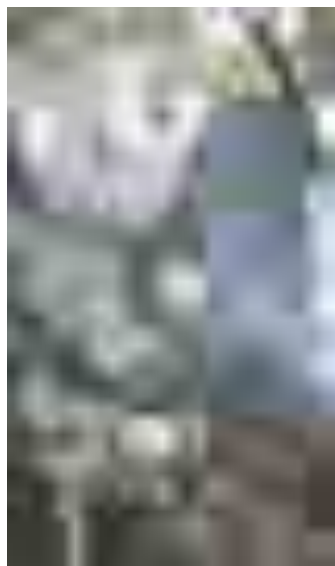

hardware pack to mount the relocation spacers through the larger un-threaded hole and into the OE swaybar mounting location. Repeat this for driver and passenger sides. ( Note the last hole closest to the rear of the vehicle should be threaded ).

108. Re-Install OE Swaybar to EVO MFG Swaybar Relocation Spacers using 2x 16MM Black Hex Bolts and a washer on each bolt. Repeat on opposite side of vehicle.
109. Assemble rear swaybar endlinks. Tap hourglass into endlink ends with mallet. Insert sleeve into center of hourglasses.
110. Install, outside of swaybar, outside of axle mount.
111. Remove factory brakeline and install supplied lines and washers.
112. Install wheels/tires.
113. Carefully cycle suspension to make sure you have appropriate clearances.
114. Follow factory procedures on bleeding brakes.
115. Turn spanner nut on top of coil spring all the way to the top. This is a starting point. This will vary on a lot of factors (added weight). Screw down if you want more lift. Added vehicle weight will make this vary.
116. Reinstall exhaust.
117. Carefully remove jack stands and lower to ground
118. Torque wheels to factory or aftermarket specifications.
119. Set vehicle onto ground. Move vehicle forward and backwards a few feet each way while turning wheel to right and left to settle vehicle.
120. Verify desired ride height. If ride height is undesirable, carefully lift front or rear of vehicle by frame until wheels are off the ground. Turn spanner up to lower ride height, down to raise ride height.
121. Repeat previous steps until desired ride height is achieved, tighten spanner clamping bolt on coilover after desired right height is set (all 4 coilovers).
122. Torque all supplied bolts to chart below. All factory bolts to factory specifications. Clean and verify no fluid leaks at Brakelines after brake application. Torque all bonded rubber control arm and trackbar bushing while vehicle is sitting on its weight.





## EVO-1160AL/EVO-1161AL/EVO-213AL

### EVO Half Doors

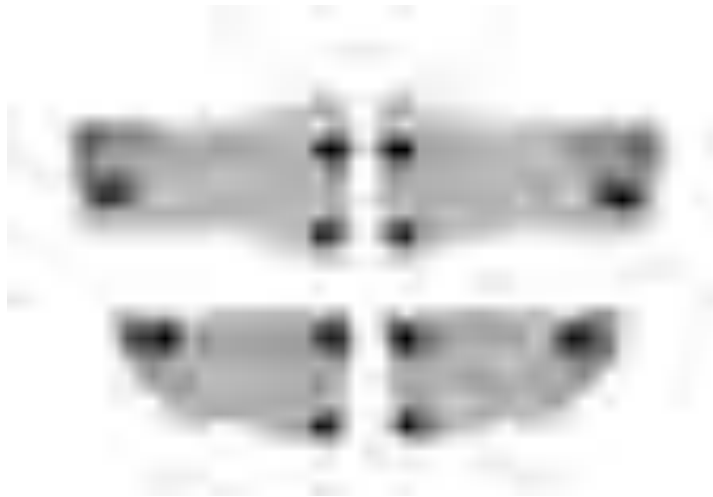

#### Bill of Materials

##### EVO-1160AL EVO Half Doors Front

Part number	Description	Quantity
EVO-12122	EVO Front Driver Door Upper	1
EVO-12123	EVO Front Driver Door Lower	1
EVO-12124	EVO Front Passenger Door Upper	1
EVO-12125	EVO Front Passenger Door Lower	1
EVO- 770055	EVO Doors Hardware Pack	1

##### EVO-1160 EVO Half Doors Rear

Part number	Description	Quantity
EVO-12126	EVO Rear Driver Door Upper	1
EVO-12127	EVO Rear Driver Door Lower	1
EVO-12128	EVO Rear Passenger Door Upper	1
EVO-12129	EVO Rear Passenger Door Lower	1
EVO-770055	EVO Doors Hardware Pack	1

1. Unplug wiring harness and release limit strap for each door. For rear doors, this will require partial removal of interior trim panels. Remove the 2 body clips directly above the strap and on the floor to access the plug and limit strap. Replace trim when finished.
2. Remove the bolts on the bottom of the hinges using a Torx size T-50.
3. Carefully lift doors out of hinges and store them in a safe place.
4. Using the supplied cap screws, a 1/8 hex (Allen) wrench and a 3/8 wrench, fasten the latches to the doors as shown below. Be sure that the "EVO" logo is oriented correctly and latch is engaged by the handle (circled below).



5. Again using the supplied cap screws, a 1/8 hex (Allen) wrench and a 3/8 wrench, attach the upper door panels to the lower door panels.
6. Loosely bolt the supplied hinges to the door panels. Don't tighten them yet.
7. Fit the door hinges into the body hinges. You may need to tap them gently with a small hammer to line them up.



8. Replace the Jeep's hinge bolts using a Torx size T-50.
9. With the hinges in place and the door latched close, tighten the hinges to the door.
10. For front doors, if mirrors are going to be used, remove the mirrors from your Jeep's doors by removing the 2 Torx T-30 screws holding them in place on the inside of the door. Attach them to your EVO Half Doors using the supplied brackets as shown below. If mirrors aren't going to be used, put the supplied black plugs in the mirror mounting holes.

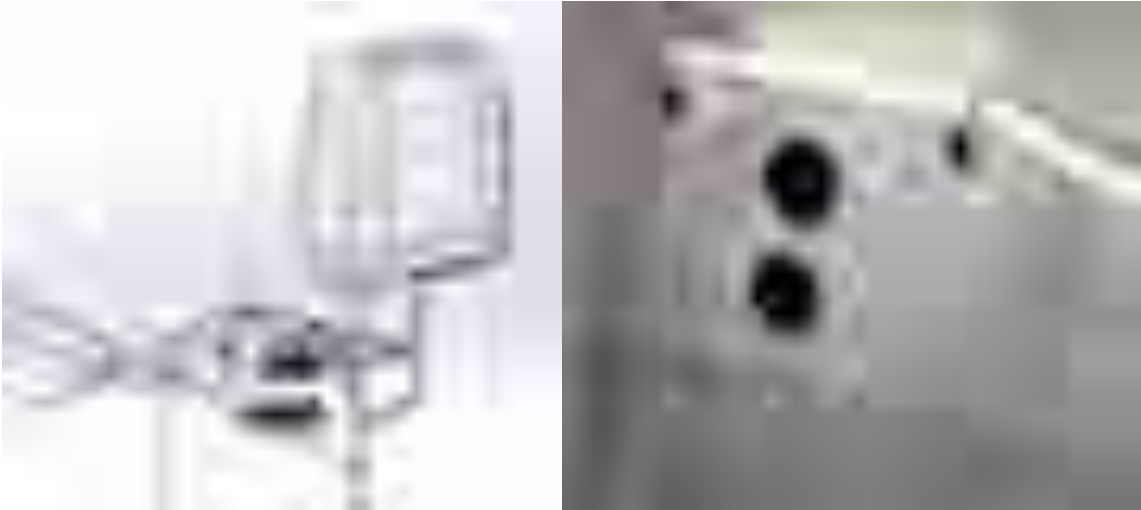



## EVO-214AL



### Bill of Materials

Part number	Description	Quantity
EVO-12139	Mini EVO Liner Passenger	1
EVO-12140	Mini EVO Liner Driver	1
EVO-900386	M-6 Lock Nut	4

**Note:** Mini EVO Liners are made and shipped in raw aluminum. They can oxidize, scratch, stain, etc. Upkeep/cleaning will be required in raw finish. It is recommended to treat in some way (paint, powder coat, etc.)

**Note:** This product requires removal of the front inner fenders. If your inner fenders are already removed, skip to step 4.

1. To remove your front factory inner fenders, begin by drilling out the 3 plastic rivets at the rear of the fender using a 3/16" drill bit.
2. Using a 10mm wrench remove the nut holding the inner fender in place.



3. Remove the panel clips using a panel clip tool or similar tool. There are a total of 4 clips. You should now be able to work your inner fender out of the wheel well.





4. On the Passenger side, fit the Mini EVO Liner's rear bolt tab to the bolt stud holding the electrical connectors in place, shown below. Thread the supplied nut on, do not tighten it at this time.



5. With the rear bolt tab in place, fit the Mini EVO Liner's front bolt tab to the bolt in the upper part of the wheel well, shown below.



6. Thread one of the supplied nuts to the bolt. To tighten, you will need to access the top of the bolt. This is under the hood, between the battery and the side wall, pictured below. You will need a 10mm wrench, a 10mm socket and a ratchet with an extension.
7. With the upper tab secured, now tighten the nut threaded onto the rear tab from step 4 using a 10mm socket and a ratchet with an extension.



8. On the Driver side, fit the Mini EVO Liner's rear bolt tab to the bolt stud and thread on a nut as before, however, you will need to be sure the bolt tab fits underneath the brake line, as shown below.



9. Fit the Mini EVO Liner's front bolt tab onto the bolt on the upper part of the wheel well (same as step 5). Again, making sure the rear tab stays in place.
10. To access the top of this nut under the hood, some JK's will require removing the horn. Remove the 10mm nut shown below and move the horn to access the bolt head below.
11. Using a 10mm wrench, 10mm socket and a ratchet with an extension, tighten the top bolt (Same as in step 6). Remember to replace your horn when you're finished.



12. With the upper tab secured, tighten the nut on the rear tab from step 8 using a 10mm socket and extension (Same as step 7).



## Alternate Firewall Configurations

- The bolt stud on the passenger side may require removal of the large plastic nut.
- On the driver side, a heat shield may need to be trimmed or bent slightly to access the bolt stud.



## Installation with EVO-1108, EVO-201-1, or EVO-202 Equipped JK's

- The hose to the passenger front shock reservoir will need to be isolated. This can be done by cutting some of the plastic above the hose allowing it to move up out of the way, like it does on the driver side. Or the hose can also be isolated using a piece of hose or tubing from a hardware store cut to size, slit and zip tied to the shock hose where it makes contact, as shown.





## EVO Manufacturing

### 4XE EVO COILOVER INSTALLATION ADDENDUM

\* This instruction is intended to be used in combination with EVO-3028 instruction. This instruction includes added installation details for 4xE Specific Installations.

Spring change note: 4xE coil over kits will require an EVO HD spring set. This spring will be used to replace the standard rear lower coil over spring.

Before starting installation procedure please read <http://evomfg.com>Returns-Warranties-Shipping>

---

**READ BEFORE INSTALL**



**Recommended Tools:**

- Socket/Tool set
- Wrenches (English/metric)
- Cut off Wheel/Sawzall
- Thread lock
- Black Spray Paint



Safety Steps for installation

- For installing EVO MFG products always use wheel chokes to block rear tires from rolling.
- Always make sure you have everything necessary ready before install.
- If you have to, carefully lift front of vehicle by front frame rails extending suspension until tires leave the ground, place frame on approved jack stands for vehicle. Verify all lines/wires are not over extended.
- Remove tires if needed for easier install.
- Make sure to wear safety equipment (eye protection, hand protection, foot protection etc.) at all times during installation.
- Make sure all safety precautions have been taken.
- Always check and replace any part of vehicle that is warn or broken before starting install.
- Do not mix anything EVO with weaker alternatives.
- It is generally a good idea to apply liquid threadlock to all bolts.
- Tighten included hardware to torque specifications in bottom table unless it is otherwise specified, factory bolts should be torqued to factory Jeep specifications.





1. Remove Plate holding harness on passenger inner fender well.





2. Trim Factory Bracket as shown removing bracket section, yellow line in image.







3. Install supplied tab as shown to cut bracket



4. Install Harness to cut factory bracket and re-install as shown to Jeep.





5. Simulate the install of EVO Coilover Shock Tower on passenger side and note/mark interference with upper wheel well structure. Mark, cut, grind material for appropriate clearance.







6. Clearance radius will likely need to be ground in passenger tower to clear hose. Clearance as needed, paint exposed metal.





After Install:

- After completing installation using provided instructions, go through all steps again to make sure nothing was missed, not tightened or improperly assembled.
- Some components may need to be purchased separately.
- Make sure all gauges are fully operational.
- Drive the vehicle slowly for a couple minutes, looking and listening for abnormal noises while driving. After modification of a vehicle there will be differences in driving experiences and capabilities, be mindful of that.
- Inspect and Retorque all Bolts after 500 miles of completed installation and regularly thereafter.

**General Recommended Torque Specs:**

Size	Grade 2		Grade 5		Grade 8		18-8 S/S	
	Coarse	Fine	Coarse	Fine	Coarse	Fine	Coarse	Fine
<b>#4*</b>	-	-	-	-	-	-	5.2	-
<b>#6*</b>	-	-	-	-	-	-	9.6	-
<b>#8*</b>	-	-	-	-	-	-	19.8	-
<b>#10*</b>	-	-	-	-	-	-	22.8	31.7
<b>1/4</b>	4	4.7	6.3	7.3	9	10	6.3	7.8
<b>5/16</b>	8	9	13	14	18	20	11	11.8
<b>3/8</b>	15	17	23	26	33	37	20	22
<b>7/16</b>	24	27	37	41	52	58	31	33
<b>1/2</b>	37	41	57	64	80	90	43	45
<b>9/16</b>	53	59	82	91	115	129	57	63
<b>5/8</b>	73	83	112	128	159	180	93	104
<b>3/4</b>	125	138	200	223	282	315	128	124
<b>7/8</b>	129	144	322	355	454	501	194	193

# EVO-813W LIGHT DRILL TEMPLATE

PRINT 100% OR 1 TO 1. VERIFY 2.00"  
USE TEMPLATE TO DRILL LIGHT MOUNTING HOLES.  
2 HOLES @ 2.00" ARE LIGHT BOLT HOLES. THESE WILL ALWAYS NEED TO BE DRILLED  
LARGE SET OF 4 HOLES ARE WIRING ROUTING HOLES.  
DEPENDING ON LIGHT ORIENTATION ONLY 1 OF THE 4 WILL NEED TO BE DRILLED FOR WIRE.

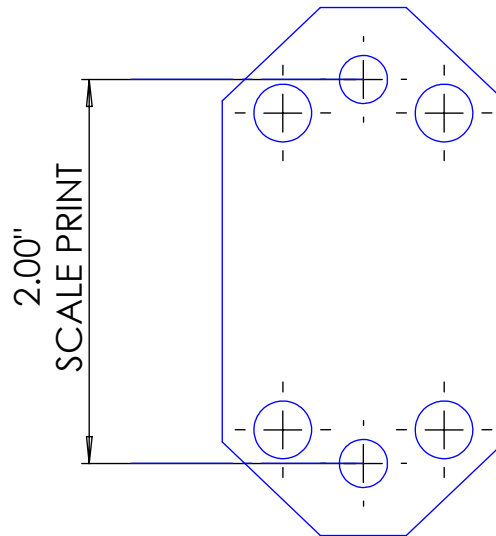



EVO Manufacturing

Jeep Wrangler JLU

JL Rock Skins

EVO- 907





Before starting installation procedure please read <http://evomfg.com>Returns-Warranties-Shipping>

**CAREFULLY READ AND FOLLOW ALL INSTRUCTIONS IN THIS MANUAL AND KEEP FOR FUTURE REFERENCE. IF YOU HAVE ANY QUESTIONS ABOUT THE PRODUCT CALL EVO MANUFACTURING. FAILURE TO FOLLOW GUIDELINES COULD RESULT IN MALFUNCTION OF PARTS OR INJURY. PLEASE HAVE A TRAINED PROFESSIONAL ASSIST WITH OR INSTALL ALL PRODUCTS. INSTALLING EVO MFG PRODUCTS OR KITS DEMANDS SPECIFIC KNOWLEDGE, TOOLS AND EXPERIENCE. GENERAL KNOWLEDGE OF HOW TO USE LATER SPECIFIED TOOLS AND/OR LIMITED EXPERIENCE WITH EVO MFG PRODUCTS MAY NOT BE ENOUGH TO PROPERLY COMPLETE THESE TASKS. SOME OF EVO MFG PRODUCTS MAY REQUIRE TWO OR MORE PEOPLE TO INSTALL SAFELY AND CORRECTLY. DO NOT ATTEMPT ALONE, ALWAYS ENLIST THE HELP OF TRAINED PROFESSIONAL WHEN NEEDED.**

**Notes: Set Up Before installation**

**This product requires permanent drilling of holes into the body of the Jeep and installing threaded inserts. Once process has started there is no going back.**

**Rivnuts/Nutserts are used in this installation. Installation tool for this is required and not included. Thread size 1/4 -20**

**Always wear approved safety equipment while performing the installation.**

**It is recommended that EVO MFG Skins are installed uncoated/painted first, then coat/paint and perform final assembly.**

**Keep all mounting bolts loose (installed but not torqued) we will torque later at the end of complete installation**

**READ BEFORE INSTALL:**

It is generally a good idea to apply Loctite to all threaded bolts.

ALWAYS wear safety glasses and other approved safety gear when working on a vehicle.

All supplied bolts torqued according to chart at end of instruction.

It is recommended all installation be performed by a trained professional. Some modification may have to be done.





Parts included: Table below shows JLU Rock Skins

Description	#	Part #	Quantity
JL Rock Skin Driver	1	EVO-12349	1
JL Rock Skin Passenger	2	EVO-12350	1
Hardware	3	EVO-770084	1





**Recommended Tools:**

- Drill and 25/64" drill bit



**Safety Steps for installation**

- For installing EVO MFG products always use wheel chokes to block rear tires from rolling.
- Always make sure you have everything necessary ready before install.
- If you have to, carefully lift front of vehicle by front frame rails extending suspension until tires leave the ground, place frame on approved jack stands for vehicle. Verify all lines/wires are not over extended.
- Remove tires if needed for easier install.
- Make sure to wear safety equipment (eye protection, hand protection, foot protection etc.) at all times during installation.
- Make sure all safety precautions have been taken.
- Always check and replace any part of vehicle that is worn or broken before starting install.
- Do not mix anything EVO with weaker alternatives.
- It is generally a good idea to apply liquid threadlock to all bolts.
- Tighten included hardware to torque specifications in bottom table unless it is otherwise specified, factory bolts should be torqued to factory Jeep specifications.





## **INSTALL**

Park vehicle on flat ground,  
parking brake engaged and  
chalk wheels.

1. Clean both sets of EVO  
MFG Rock Skins.
- 





2. Hold EVO MFG Rock Skin to vehicle and align Rock Skin using body lines/door openings. Once you find a fit that works for you, mark the 4 centermost holes between the doors.

**Before drilling it is the installers responsibility to verify fitment is acceptable. There is no turning back from here.**

3. Once the skins are in your acceptable position, using the 4 marked holes in the Rock Skin drill through the outer sheet metal of body only using a 25/64" drill bit.

Step Drill recommended

---



4. Follow manufacturers tool procedure and install nutserts into 4 drilled holes.
- 





5. Replace EVO MFG Rock Skin on the side of the vehicle and bolt to body (snug) in the 4 locations with installed nutserts. DO NOT overtighten bolts.
  6. Once Skin is bolted to body, press Skin flush to body, mark all other holes for drilling. Forward and rearward of center.
  7. Remove Skin from body. Follow tool procedure to drill holes and insert remaining nutserts.
- 



8. Loosely install Rock Skin at all bolt locations and repeat previous steps on alternate side.
- 





Lastly tighten down Rock Skin bolts.



After Install:

- Tighten all bolts securing purchased parts to specified locations.
- After completing installation using provided instructions, go through all steps again to make sure nothing was missed, not tightened or improperly assembled.
- Some components may need to be purchased separately.
- Check turn signals, headlights, fog lights (if applicable), taillights, blinkers and windshield wipers.
- Adjust mirrors, speedometer and headlights if needed.
- Make sure all gauges are fully operational.
- Drive the vehicle slowly for a couple minutes, looking and listening for abnormal noises while driving. After modification of a vehicle there will be differences in driving experiences and capabilities, be mindful of that.
- Inspect and Retorque all Bolts after 500 miles of completed installation and regularly thereafter.
- Some modification may be required.



Recommended Torque:

Size	Grade 2		Grade 5		Grade 8		18-8 S/S	
	Coarse	Fine	Coarse	Fine	Coarse	Fine	Coarse	Fine
<b>#4*</b>	-	-	-	-	-	-	5.2	-
<b>#6*</b>	-	-	-	-	-	-	9.6	-
<b>#8*</b>	-	-	-	-	-	-	19.8	-
<b>#10*</b>	-	-	-	-	-	-	22.8	31.7
<b>1/4</b>	4	4.7	6.3	7.3	9	10	6.3	7.8
<b>5/16</b>	8	9	13	14	18	20	11	11.8
<b>3/8</b>	15	17	23	26	33	37	20	22
<b>7/16</b>	24	27	37	41	52	58	31	33
<b>1/2</b>	37	41	57	64	80	90	43	45
<b>9/16</b>	53	59	82	91	115	129	57	63
<b>5/8</b>	73	83	112	128	159	180	93	104
<b>3/4</b>	125	138	200	223	282	315	128	124
<b>7/8</b>	129	144	322	355	454	501	194	193
<b>1†</b>	188	210	483	541	682	764	287	289



## EVO-1005 JK Front Lower Control Arm Skids



**Caution:** This kit requires welding. Welding creates a very bright arc that should not be looked at without an approved protective shield/clothing. Welded surfaces and areas in their vicinity will be very hot for a long period of time after welding. Please use caution. All welding should be performed by a professional.

	QTY	PART#	DESCRIPTION
<input type="checkbox"/>	1	EVO-760001	BOX 7x4x3
<input type="checkbox"/>	1	EVO-10022	Pass Front CA Skids, JK Front Axle
<input type="checkbox"/>	1	EVO-10023	Driver Front CA Skids, JK Front Axle



1. Elevate front of vehicle securely on jack stands
2. Remove control arm on driver side from axle, leave control arm attached to frame side mount. Do not remove both driver and passenger side lower control arms at the same time.
3. Clean all paint in the areas to be welded on the factory bracket and axle tube and place EVO-10023 on driver factory axle bracket
4. Weld EVO Skid on all edges that the EVO Skid touches the factory control arm bracket and/or the axle tube
5. Let cool, then paint all exposed metal
6. Reinstall control arm, torque to factory specifications
7. Repeat steps 2-6 on passenger side with EVO-10022 bracket
8. If wheels were removed from vehicle, Reinstall wheels and torque all nuts to factory specifications  
Retorque all bolts/nuts after first 500 miles.



## EVO-1006 C2 Axle Gusset Kit, JK



	<b>QTY</b>	<b>PART#</b>	<b>DESCRIPTION</b>
□	2	EVO-10020	Upper Knuckle Gusset
□	2	EVO-10021	Lower Knuckle Gusset

**Caution: This kit requires welding. Welding creates a very bright arc that should not be looked at without an approved protective shield/clothing. Welded surfaces and areas in their vicinity will be very hot for a long period of time after welding. Please use caution. All welding should be performed by a professional.**

1. Elevate front of vehicle securely by frame, fully extend suspension.
2. Remove front wheels.
3. It is highly recommended that the ball joints on the both top and bottom of the Axle C's on both sides of the axle be removed with the recommended Jeep ball joint puller. See service manual for instructions.
4. Place C2 Axle Gussets on top and bottom of driver side axle by hand. Mark axle with paint pen/marker where all surfaces are to be welded.
5. Remove C2's and repeat step 3 on Passenger side.
6. Clean all surfaces of paint/coating around the marks made in step's 3 and 4 with a wire wheel or sanding disk.
7. Place Upper Gussets in place on both driver and passenger side. Make sure that C2's seat fully against spring perch. Tap with rubber mallet if required.
8. Verify that all coating/paint is cleaned from all areas to be welded.
9. Tack both driver and passenger C2's in place.
10. Weld gussets in no more than 1 inch increments alternating from driver to passenger sides after every increment. After welding each increment before alternating to the opposite side, cool welded surface.
11. Place lower Axle C2's in place on driver side.
12. Tack weld into place.
13. Verify that all coating/paint is cleaned from all areas to be welded.
14. Repeat steps 11-13 on passenger side.
15. Weld gussets in no more than 1 inch increments alternating from driver to passenger sides after every increment. After welding each increment before alternating to the opposite side, cool welded surface.
16. Clean all area of slag and burn off with cleaner.
17. Paint all uncoated surfaces.



## EVO-1008 Rear Double ThrowDown



	QTY	PART#	DESCRIPTION
<input type="checkbox"/>	1	EVO-10047DS	DRIVER DOUBLE THROWDOWN ARM, SILVER
<input type="checkbox"/>	1	EVO-10047PS	PASS DOUBLE THROWDOWN ARM, SILVER
<input type="checkbox"/>	1	EVO-10003	DTD EVOLEVER SUBFRAME
<input type="checkbox"/>	1	EVO-10005	CANTI TRACK BRACKET
<input type="checkbox"/>	1	EVO-10006	DRVR HEIM MOUNT BRACKET
<input type="checkbox"/>	1	EVO-10007	EVOLEVER FRAME SIDE TRACKBAR RELO
<input type="checkbox"/>	2	EVO-10008CZ	ENDLINK TUBE, CANTILEVER ARM
<input type="checkbox"/>	2	EVO-600003	3/4 MALE RH HEIM
<input type="checkbox"/>	2	EVO-600036	3/4 MALE LH HEIM
<input type="checkbox"/>	2	EVO-900255	3/4 RH HEX JAM NUT
<input type="checkbox"/>	2	EVO-900256	3/4 LH HEX JAM NUT
<input type="checkbox"/>	8	EVO-750500175	MISALIGNMENT, 3/4
<input type="checkbox"/>	8	EVO-900257	HOSE CLAMP
<input type="checkbox"/>	8	EVO-900267	TABS
<input type="checkbox"/>	2	EVO-600039	20" LIMIT STRAP
<input type="checkbox"/>	2	EVO-11024CZ	CROSS BRACE Clear Zinc
<input type="checkbox"/>	4	EVO-625500150	MISALIGNMENT 5/8
<input type="checkbox"/>	4	EVO-600028	5/8 MALE RH HEIM
<input type="checkbox"/>	4	EVO-900254	5/8 RH HEX JAM NUT
<input type="checkbox"/>	1	EVO-770020	EVOLEVER HARDWARE PACK
<input type="checkbox"/>	4	EVO-900270	Cantilever Bushing

1. Elevate the vehicle securely
2. Secure rear axle on adjustable jack
3. Remove bolt retaining brakeline bracket from frame
4. Remove rear shocks
5. Remove rear swaybar endlinks
6. Remove rear springs
7. Remove rear trackbar
8. Remove rear swaybar from frame
9. Remove two bolts on inside of rear most cross-member
10. Apply a film of moly grease to the inside and outside diameter of pivot bushings
11. Insert greased bushings into cantilever arms. Two in each arm
12. Grease outer diameter of the pivot tube
13. Insert greased pivot tube into inner diameter of pivot bushings until both sides of pivot tube are flush with bushings
14. Cut coil bucket as marked on both sides of vehicle
15. Place subframe into position
16. Using factory hardware bolt two rear bolts into rear cross-member
17. Using the 4 bolts from the removed factory sway bar, install into forward portion of subframe
18. Remove driver rear brake caliper and rotor.  
Using a hole saw/rotary file, cut a 1" hole in dust shield, inline with the upper factory control arm bolt. Remove upper control arm bolt on driver axle and insert through the dust shield hole into control arm bracket.
19. Reinstall rotor and caliper to factory specifications

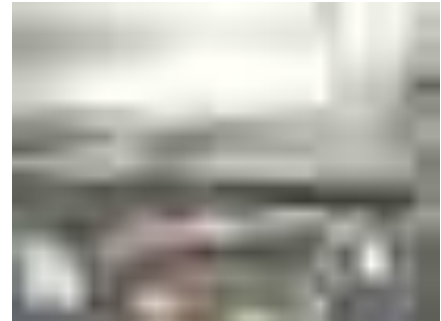

20. Install assembled EVO arms to pivot locations on the subframe with supplied 9/16" hardware



21. Place axle trackbar bracket into place on axle pad

22. Using supplied u-bolts and hardware, bolt into position

23. Insert 1/2" hardware and nut plate from top down into the factory spring mount.

24. Install passenger side endlink bracket with u-bolt and 1/2" hardware and nut plate



25. Grind bumpstop mount on frame smooth as seen in photo. Passenger side only.



26. Install Frameside Trackbar/bumpstop bracket into place. Install 1/2" x 1" bolt from factory trackbar bracket through into EVO bracket

27. Mark center of three holes on frame

28. Drill rear two holes through with 1/2" drill bit

29. Drill forward single hole through outer side only with 1/2" drill bit

30. Install 2 1/2" x 4" bolts into through drilled holes

31. Install 1/2" x 1" bolt into forward hole.

32. Insert nut plate from large hole in frame and thread onto forward 1/2" bolt



33. Fully thread  $\frac{3}{4}$ " jam nuts onto  $\frac{3}{4}$ " heim joints, two are left hand thread and two are right hand thread
34. Fully thread heim joints into EVO endlinks, one right hand and one left hand thread each endlink
35. Insert mis-alignments into heims on EVO endlinks, two per heim joint

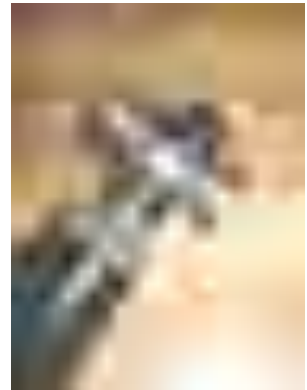

36. Using  $\frac{1}{2}$ " hardware install one end of EVO endlink with mis-alignments into large end of EVO arm on driver side



37. Using  $\frac{1}{2}$ " hardware install opposite end of EVO endlink into driver side axle trackbar mount

38. Using  $\frac{1}{2}$ " hardware install one end of EVO endlink with mis-alignments into large end of EVO arm on passenger side

39. Using  $\frac{1}{2}$ " hardware install opposite end of EVO endlink into passenger side axle mount



40. Assemble EVO cross brace links, thread jamb nuts on each heim and thread each heim into cross brace tube.



41. Install Driverside cross brace on EVO DTD cantilever arm, and other end with misalignments to the EVO DTD Subframe, Repeat these steps for Passenger side.



42. Install factory trackbar into frame side mount in factory orientation with factory hardware

If aftermarket is used, verify no interference issues with EVO arms

43. Install opposite end of trackbar into axle bracket with factory hardware

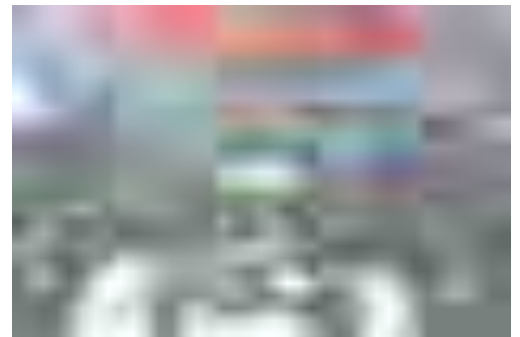

44. Install Coilover into rear mounting location on driver side with spacers and ½" x 2.5" hardware. Repeat these steps with Bypass shock.

45. Install Coilover into EVO arm on driver side with spacers and ½" x 2.5" hardware. Repeat these steps with Bypass shock.



46. Install Coilover into rear mounting location on passenger side with spacers and ½" x 2.5" hardware. Repeat these steps with Bypass shock.

47. Install Coilover into EVO arm on passenger side with spacers and ½" x 2.5" hardware. Repeat these steps with Bypass shock.





48. Coilover Reservoir tabs can either be mounted on the outside of the frame or on the EVO subframe with Bypass Reservoirs. Use two tabs and two hose clamps per reservoir.

49. Install factory swaybar to tabs on lower side of the subframe using the supplied 3/8 bolts, washers and lock nuts

50. Thread 1/2" studded heim joints (one left thread and one right thread) into each hex bar linkage.

51. Mount link into swaybar and factory axle location with supplied 1/2" washers and nuts. **On passenger side upper stud of swaybar: cut remaining tread off after nut is fully tightened.**

52. Install limit straps on subframe end with 1/2"x1.5" bolts

53. Install brakelines back into factory location. Verify brakelines are correct length

54. Using a 1/2" drill bit, enlarge hold on axle

55. Install lower mount of limit strap into drilled holes with 1/2"x1.0" bolt, washers and nuts

56. Reinstall tires and torque to factory specifications.

57. Re-torque all bolts after first 100 miles

58. Re-torque all bolts every 3000 miles and after every off road use.

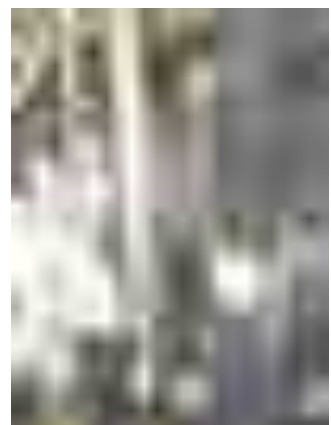



## **EVO-1010 JK Front Double ThrowDown**



**Caution: This kit requires welding. Welding creates a very bright arc that should not be looked at without an approved protective shield and clothing. Welded surfaces and areas in their vicinity will be very hot for a long period of time after welding. Please use caution. All welding should be performed by a professional. MIG welding is the preferred method. Remove/ Uninstall shocks prior to welding.**

**By purchasing this kit you are starting the next level of performance. To install this kit it requires work and finesse. This high quality system will truly enhance your vehicle to another level. Cutting, Welding, and Grinding required; not bitching and moaning. This is a toy, it should be fun!**

QTY	PART#	DESCRIPTION
☐	1	EVO- 760006 BOX 24x6x6
☐	1	EVO-10048 DTD Driver Tower
☐	1	EVO-10049 DTD Pass Tower
☐	2	EVO-10048-4 Forward Tower Gusset
☐	2	EVO-10048-5 Reward Tower Gusset
☐	2	EVO-10046 Axle Shock Mount Assembly
☐	2	EVO-770008 EVO Shock Mounting Hardware Pack
☐	4	EVO-900257 SAE 40 Worm Drive Hose Clamp
☐	4	EVO-900267 2.0 Reservoir Mount Tab

1. Elevate front of vehicle securely
2. Remove front wheels
3. Secure axles with adjustable jack stands
4. Remove front sway bar end links
5. Remove front shocks
6. Remove front springs
7. Remove inner fender liners
8. Remove brakeline bolts from frame and carefully move brakeline out of the way of tower.
9. Cut coil/shock tower off of frame using plasma cutter, torch, cut off wheel and/or reciprocating saw. There are delicate components in the vicinity of these parts that can be easily damaged, such as wiring and brakelines. Move/remove and use a fire retardant blanket to protect/cover these components. See Photo



10. Sand frame smooth where coil/shock towers once were and remove paint from surfaces to be welded
11. Place DTD tower on top of the frame with the forward most edge of tower just rearward of the large round hole in the frame rail. Make

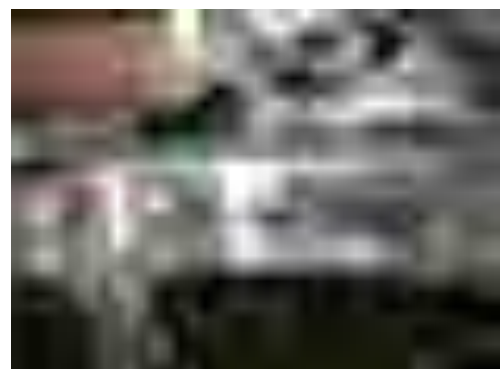

sure tower does not contact steering shaft on driver side.

12. Mark on DTD tower where sanding is required to contour to the frame.
13. Sand DTD tower to contour to the frame so that all gaps between the tower and frame are weldable.
14. Place contoured tower back into position and tack weld (multiply locations) into place. It is not recommended to fully weld at this point. **Verify that steering shaft does not come into contact with shock tower on driver side. If so, re-adjust tower or clearance back of tower.**
15. Take weld outer gussets in place on front and rear sides of DTD tower
16. Carefully remove factory lower spring perch and shock mount from axle. Sand smooth to axle tube.
17. Repeat on passenger side



18. Install coilover without springs and bypass shock into upper DTD tower. Coilover should be in front of the vehicle, bypass should be in the rear.
19. Release the nitrogen from all four front shocks
20. Install lower ends of shocks into lower mount. **Make sure the more spacious side of the lower mount is used for the bypass mount.**
21. Place lower mount around axle tube as close to the axle C as possible while still being able to install/remove shock bolts.
22. Raise axle until both front shocks are fully compressed on both sides of the vehicle. Rotating the lower mount on the axle tube may be required to compress both shocks on both sides.

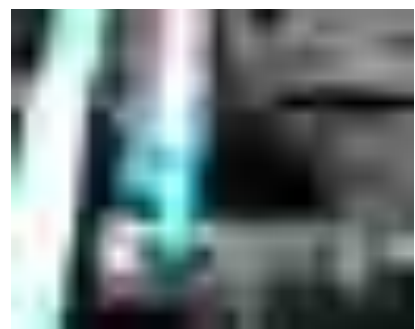

23. Once both shocks on both sides are compressed tack weld lower axle mount to axle tube.
24. Install brakelines back into frame mounts.  
Front EVO HD SwayBar Endlink Install (Optional, Sold Separately)  
If reinstalling front swaybar endlinks, reinstall now. Verify length is accurate.
25. Thread rod ends into endlinks with jam nuts
26. Enlarge holes in front sway bar with ½" drill
27. Install endlinks to sway bar and axle mount. Insert the stud on the rod end from the outside in on the sway bar and the inside out on the axle
28. Using the reservoir tabs and hose clamps, clamp tabs to reservoirs, one on each end and hold in desired location. Recommended location is mounted to the front edge of the coil tower (coilover) and along frame rail (bypass)
29. Tack weld tabs into place
30. Cycle suspension up until shocks bottom out and down until shocks are fully extended. Turn wheels to right and left when suspension is fully up and when suspension is fully down. While doing so verify that all brakelines, wiring and other components do not hyperextend or come into contact with anything. Longer brakelines may be required. ABS wires can be extended by adjusting the rubber grommets on the line. While suspension is fully extended adjust sway bar endlinks
31. Remove shocks
32. Fully weld all components into place on all areas that can be welded
33. Paint all bare metal surfaces
34. Install springs onto shocks
35. Turn spanner nut, compressing the spring until the distance of the threaded portion between the shock end cap and the spanner is approximately 2.5". This is should yield approximately 4" of lift. Adjust distance for desired ride height. Turning spanner may require a pin or spanner tool to turn.
36. Reinstall coilover/bypass shocks w/springs
37. Reinstall wheels to factory specs
38. Set vehicle onto ground. Move vehicle forward and backwards a few feet each way while turning wheel to right and left to settle vehicle.
39. Verify desired ride height. If ride height is undesirable, carefully lift front of vehicle by frame until wheels are off the ground. Turn spanner up to lower ride height, down to raise ride height.
40. Repeat steps 38 and 39 until desired ride height is achieved
41. Tighten clamping bolt on spanner.



Re-torque all bolts after first 100 miles

Re-torque all bolts every 3000 miles and after every off road use.

Size	Recommended Torque											
	Grade 2		Grade 5		Grade 8		18-8 S/S		Bronze		Brass	
	Coarse	Fine	Coarse	Fine	Coarse	Fine	Coarse	Fine	Coarse	Fine	Coarse	Fine
<b>#4*</b>	-	-	-	-	-	-	5.2	-	4.8	-	4.3	-
<b>#6*</b>	-	-	-	-	-	-	9.6	-	8.9	-	7.9	-
<b>#8*</b>	-	-	-	-	-	-	19.8	-	18.4	-	16.2	-
<b>#10*</b>	-	-	-	-	-	-	22.8	31.7	21.2	29.3	18.6	25.9
<b>1/4</b>	4	4.7	6.3	7.3	9	10	6.3	7.8	5.7	7.3	5.1	6.4
<b>5/16</b>	8	9	13	14	18	20	11	11.8	10.3	10.9	8.9	9.7
<b>3/8</b>	15	17	23	26	33	37	20	22	18	20	16	18
<b>7/16</b>	24	27	37	41	52	58	31	33	29	31	26	27
<b>1/2</b>	37	41	57	64	80	90	43	45	40	42	35	37
<b>9/16</b>	53	59	82	91	115	129	57	63	53	58	47	51
<b>5/8</b>	73	83	112	128	159	180	93	104	86	96	76	85
<b>3/4</b>	125	138	200	223	282	315	128	124	104	102	118	115
<b>7/8</b>	129	144	322	355	454	501	194	193	178	178	159	158
<b>1†</b>	188	210	483	541	682	764	287	289	265	240	235	212



## **EVO-1010 JK Front Double ThrowDown**



**Caution: This kit requires welding. Welding creates a very bright arc that should not be looked at without an approved protective shield and clothing. Welded surfaces and areas in their vicinity will be very hot for a long period of time after welding. Please use caution. All welding should be performed by a professional. MIG welding is the preferred method. Remove/ Uninstall shocks prior to welding.**

**By purchasing this kit you are starting the next level of performance. To install this kit it requires work and finesse. This high quality system will truly enhance your vehicle to another level. Cutting, Welding, and Grinding required; not bitching and moaning. This is a toy, it should be fun!**

QTY	PART#	DESCRIPTION
☐	1	EVO- 760006 BOX 24x6x6
☐	1	EVO-10048 DTD Driver Tower
☐	1	EVO-10049 DTD Pass Tower
☐	2	EVO-10048-4 Forward Tower Gusset
☐	2	EVO-10048-5 Reward Tower Gusset
☐	2	EVO-10046 Axle Shock Mount Assembly
☐	2	EVO-770008 EVO Shock Mounting Hardware Pack
☐	4	EVO-900257 SAE 40 Worm Drive Hose Clamp
☐	4	EVO-900267 2.0 Reservoir Mount Tab

1. Elevate front of vehicle securely
2. Remove front wheels
3. Secure axles with adjustable jack stands
4. Remove front sway bar end links
5. Remove front shocks
6. Remove front springs
7. Remove inner fender liners
8. Remove brakeline bolts from frame and carefully move brakeline out of the way of tower.
9. Cut coil/shock tower off of frame using plasma cutter, torch, cut off wheel and/or reciprocating saw. There are delicate components in the vicinity of these parts that can be easily damaged, such as wiring and brakelines. Move/remove and use a fire retardant blanket to protect/cover these components. See Photo



10. Sand frame smooth where coil/shock towers once were and remove paint from surfaces to be welded
11. Place DTD tower on top of the frame with the forward most edge of tower just rearward of the large round hole in the frame rail. Make

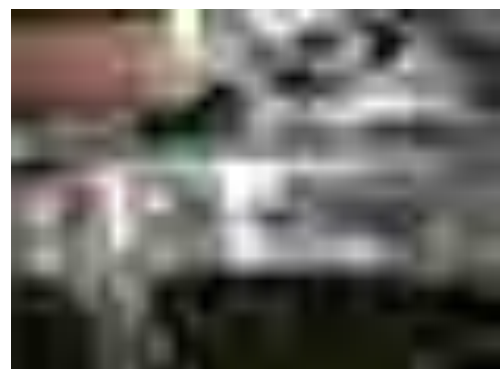



sure tower does not contact steering shaft on driver side.

12. Mark on DTD tower where sanding is required to contour to the frame.
13. Sand DTD tower to contour to the frame so that all gaps between the tower and frame are weldable.
14. Place contoured tower back into position and tack weld (multiply locations) into place. It is not recommended to fully weld at this point. **Verify that steering shaft does not come into contact with shock tower on driver side. If so, re-adjust tower or clearance back of tower.**
15. Take weld outer gussets in place on front and rear sides of DTD tower
16. Carefully remove factory lower spring perch and shock mount from axle. Sand smooth to axle tube.
17. Repeat on passenger side



18. Install coilover without springs and bypass shock into upper DTD tower. Coilover should be in front of the vehicle, bypass should be in the rear.
19. Release the nitrogen from all four front shocks
20. Install lower ends of shocks into lower mount. **Make sure the more spacious side of the lower mount is used for the bypass mount.**
21. Place lower mount around axle tube as close to the axle C as possible while still being able to install/remove shock bolts.
22. Raise axle until both front shocks are fully compressed on both sides of the vehicle. Rotating the lower mount on the axle tube may be required to compress both shocks on both sides.

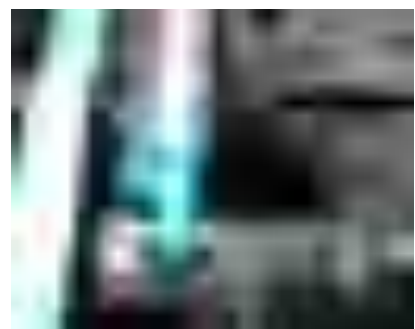

23. Once both shocks on both sides are compressed tack weld lower axle mount to axle tube.
24. Install brakelines back into frame mounts.  
Front EVO HD SwayBar Endlink Install (Optional, Sold Separately)  
If reinstalling front swaybar endlinks, reinstall now. Verify length is accurate.
25. Thread rod ends into endlinks with jam nuts
26. Enlarge holes in front sway bar with ½" drill
27. Install endlinks to sway bar and axle mount. Insert the stud on the rod end from the outside in on the sway bar and the inside out on the axle
28. Using the reservoir tabs and hose clamps, clamp tabs to reservoirs, one on each end and hold in desired location. Recommended location is mounted to the front edge of the coil tower (coilover) and along frame rail (bypass)
29. Tack weld tabs into place
30. Cycle suspension up until shocks bottom out and down until shocks are fully extended. Turn wheels to right and left when suspension is fully up and when suspension is fully down. While doing so verify that all brakelines, wiring and other components do not hyperextend or come into contact with anything. Longer brakelines may be required. ABS wires can be extended by adjusting the rubber grommets on the line. While suspension is fully extended adjust sway bar endlinks
31. Remove shocks
32. Fully weld all components into place on all areas that can be welded
33. Paint all bare metal surfaces
34. Install springs onto shocks
35. Turn spanner nut, compressing the spring until the distance of the threaded portion between the shock end cap and the spanner is approximately 2.5". This is should yield approximately 4" of lift. Adjust distance for desired ride height. Turning spanner may require a pin or spanner tool to turn.
36. Reinstall coilover/bypass shocks w/springs
37. Reinstall wheels to factory specs
38. Set vehicle onto ground. Move vehicle forward and backwards a few feet each way while turning wheel to right and left to settle vehicle.
39. Verify desired ride height. If ride height is undesirable, carefully lift front of vehicle by frame until wheels are off the ground. Turn spanner up to lower ride height, down to raise ride height.
40. Repeat steps 38 and 39 until desired ride height is achieved
41. Tighten clamping bolt on spanner.



Re-torque all bolts after first 100 miles

Re-torque all bolts every 3000 miles and after every off road use.

Size	Recommended Torque											
	Grade 2		Grade 5		Grade 8		18-8 S/S		Bronze		Brass	
	Coarse	Fine	Coarse	Fine	Coarse	Fine	Coarse	Fine	Coarse	Fine	Coarse	Fine
#4*	-	-	-	-	-	-	5.2	-	4.8	-	4.3	-
#6*	-	-	-	-	-	-	9.6	-	8.9	-	7.9	-
#8*	-	-	-	-	-	-	19.8	-	18.4	-	16.2	-
#10*	-	-	-	-	-	-	22.8	31.7	21.2	29.3	18.6	25.9
1/4	4	4.7	6.3	7.3	9	10	6.3	7.8	5.7	7.3	5.1	6.4
5/16	8	9	13	14	18	20	11	11.8	10.3	10.9	8.9	9.7
3/8	15	17	23	26	33	37	20	22	18	20	16	18
7/16	24	27	37	41	52	58	31	33	29	31	26	27
1/2	37	41	57	64	80	90	43	45	40	42	35	37
9/16	53	59	82	91	115	129	57	63	53	58	47	51
5/8	73	83	112	128	159	180	93	104	86	96	76	85
3/4	125	138	200	223	282	315	128	124	104	102	118	115
7/8	129	144	322	355	454	501	194	193	178	178	159	158
1†	188	210	483	541	682	764	287	289	265	240	235	212



## **EVO-1017 EVO MFG Trail Table**



**Note: This kit requires drilling. Table can be mounted with table folding up or down. Recommended installation is table folding up.**

	QTY	PART#	DESCRIPTION
□	1	EVO-10032B	Table Plate, Jeep Tailgate Table
□	1	EVO-10033B	Mounting Plate, Jeep Tailgate Table
□	2	EVO-10034B	Hinge Plate, Jeep Tailgate Table
□	1	EVO-10035B	Hinge Plate with Stop Left
□	1	EVO-10036B	Hinge Plate with Stop Right
□	1	EVO-900274	NUT PLATE
□	1	EVO-900275	Thumb Screw
□	1	EVO-7700001	EVO Trail Table Hardware Pack

1. Remove plastic cover along rear tailgate. Optional reinstall, step 14.
2. Hold panel that mounts to door against rear tailgate. Upper right hand bolt hole should be aligned with spot weld (circled) in photo. Level backing plate to door. This is a reference starting hole location. Verify that this location will not interfere with any of the surrounding areas, including optional factory subwoofer etc.
3. Mark center of all 6 holes. You will be installing supplied nutserts in 5 of the 6 holes.
4. Drill the center of all marked holes (6 holes total) with a 3/8" diameter drill bit, a pilot hole approx 1/4" drilled first will ease drilling. **Only drill thru the inside panel of the tailgate.** See photo
5. From hardware pack EVO770001, Insert the nutserts into the drilled holes with the flange side out until the flange is fully seated against the tailgate. This may require a light tap with a hammer/mallet to fully insert.
6. Only install the nutserts into the 3 holes that are countersunk on the backing plate and 2 outer holes that are not countersunk. Do not install the nutserts on center none countersunk of the backing plate.
7. Fully thread the long 1/2" bolt with nut into the nutsert as seen in photo. With wrenches hold the bolt stationary and turn the nut 2 - 3 turns making sure that the nutsert does **NOT** turn. Nutsert installation tools are available. Call for details.
8. Repeat step 6 for all five nutserts. Two extra nutserts are supplied.
9. Hold EVO10033 backing plate to the tailgate.
10. Using the 1/4-20 flat top Screws from hardware pack EVO770001, fasten plate to tailgate in the 3 countersunk hole locations. Using the bottom head screws in the two other hole locations.
11. Using the 1/4-20 Button Head Screws, washers and lock nuts from hardware pack EVO770001, mount table to narrow tabs of backing plate with three washers per bolt. One washer against head of screw, one washer between the table and the backing plate and one washer against nut. See Photo.



12. Mount the hinge plates as seen in the photo. The hinge plates with the bent detent should be mounted to the backing plate on the tailgate with the detent side mounted to the other hinge plate and facing towards the center of the table on both sides.
13. Make sure that three washers are used for every bolt as explained in step 10. The middle hinge bolt should be inserted from the inside out.



14. Snug all bolts to desired torque. The tighter the bolts, the firmer the table will be to fold.



15. Using supplied thumb screw, thread into nut clip on 6<sup>th</sup> hole location through the hole in the table top to secure in the closed position.

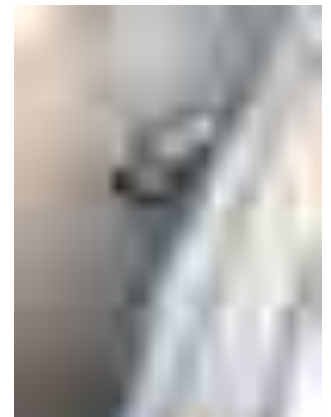

16. Optional: Cut the plastic cover 5" from left side and reinstall to tailgate.

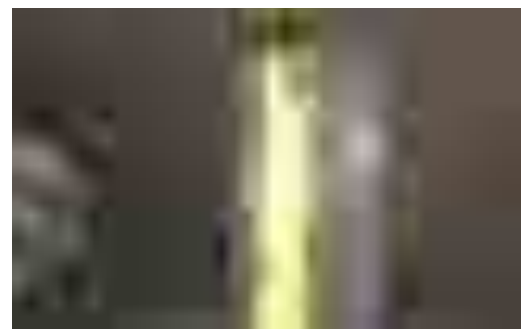



**EVO-1036**

## **EVO MFG HD Swaybar Endlinks**



**EVO MFG HD Swaybar Endlinks come unassembled from our facility. To properly assemble the EVO HD Swaybar Endlinks follow these steps.**

- Install a Jam Nut on each Endlink Heim as illustrated in photo above.  
**NOTE;** There are 2 Left Hand Thread Heims and Jam Nuts as well as 2 Right Hand Thread Heims, and Jam Nuts.
- Install the Heim Joints into the EVO HD Swaybar Endlink Hex Bars. The Hex Bar has a groove on the end which is Left Hand Thread as shown in photo. Set to desired length and tighten jam nut down to hex bar. You should now have two assembled EVO HD Swaybar Endlinks ready to install on your vehicle.
- Use the included washers and locking nuts to secure the EVO HD Swaybar Endlinks to your vehicle. Torque to 60 ft LBS. **DO NOT OVER TORQUE**



## **EVO-1038**

### **EVO MFG RockStar Skids**



	<b>QTY</b>	<b>PART#</b>	<b>DESCRIPTION</b>
<input type="checkbox"/>	1	EVO-760005	<b>BOX 8x8x8</b>
<input type="checkbox"/>	1	EVO-10040B	Pass RockStar Skid, JK, BLACK
<input type="checkbox"/>	1	EVO-10041B	Driver RockStar Skid, JK, BLACK
<input type="checkbox"/>	1	EVO-770007	RockStar, JK Hardware Pack



**NOTE:**

**This kit raises your rear lower shock location approximately 1.5". It is recommended that you cycle your suspension before and after installation and check for travel and interference issues. This kit requires cutting and grinding. It is recommended that a rear trackbar relocation bracket and adjustable trackbar be used with this kit. This kit may require new rear swaybar endlinks, wheel spacers and/or coil retainers for proper install.**

1. Elevate rear of vehicle securely until tires leave ground
2. Support rear axle with jack stands
3. Remove rear wheels
4. Remove rear shocks
5. Remove rear sway bar links
6. Remove driver rear lower control arm
7. With a paint pen, mark 1.5" down from center of lower control arm hole in the factory axle bracket
8. Carefully, with a Cutoff Wheel/Reciprocating Saw, cut along line, all the way around the control arm pocket and factory swaybar tab.
9. Sand remaining shock tabs, swaybar tab and cut surface smooth
10. Paint all exposed metal surfaces
11. Install driver Rock Star as seen in the photo
12. Install the 3/8" bolts, washers on both sides and lock nuts into the rear two holes on the driver side control arm bracket. The lower 3/8" bolt should be inserted from front to rear. The upper 3/8" should be inserted from the rear to the front. See photo
13. Reinsert lower control arm into the frame and axle mounting brackets
14. Using the factory bolt, reinsert into factory hole with Rock Star brackets in place

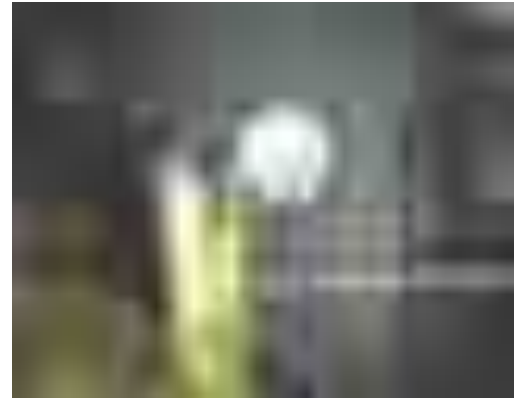

- 15.Reinsert control arm bolt on frame side
- 16.Tighten 3/8" hardware to 40 ft-lbs
- 17.Reinstall rear swaybar link into its new location on the Rock Star and into the swaybar. Verify swaybar links are correct length.
- 18.Verify rear brake lines are long enough and have not interference.
- 19.Reinstall shock with factory hardware on top and the supplied 1/2" x 3.5" on the lower mount of the shock. Torque 1/2" bolts to 90 ft-lbs and factory upper bolts to factory specifications
- 20.Reinstall rear brake caliper to factory specifications
- 21.Repeat step 5-21 on the Passenger side
- 22.Reinstall wheels
- 23.Carefully place vehicle on ground
- 24.Torque lower control arm bolts to factory specifications
- 25.Torque lug nuts to factory specifications

EVO...





## EVO-1039 EVO MFG Rear Control Arm Skids



	<b>QTY</b>	<b>PART#</b>	<b>DESCRIPTION</b>
<input type="checkbox"/>	1	EVO-760002	<b>BOX 7x5x4</b>
<input type="checkbox"/>	1	EVO-10042-1	Rear Lower CA Skid, Driver
<input type="checkbox"/>	1	EVO-10043-1	Rear Lower CA Skid, Pass
<input type="checkbox"/>	2	EVO-10042-2	Inner Gusset Plate, Rear
<input type="checkbox"/>	2	EVO-10042-3	Outer Gusset Plate, Rear

1. Carefully lift rear of vehicle
2. Support axle with jack stands
3. Remove rear tires
4. Remove rear shocks
5. Remove driver side lower control arm
6. Clean all areas to be welded or paint and coatings with sander/wire brush
7. Place 10042-1 against control arm pocket as seen in the photo. Center evenly on control arm pocket. Tack weld in 3-4 locations
8. Place 10042-2 on inner side of shock pocket. Tack into place
9. Place 10042-3 (slightly longer than 10042-2) on outer side of shock pocket. Take into place
10. Verify all areas to be welded are clean of paint
11. Fully weld all areas of contact.



12. Paint all bare metal areas with aerosol paint
13. Repeat steps 6-12 on passenger side
14. Reinstall control arms. They now need to be loaded from the front to rear. They cannot be installed from the bottom any longer. Rolling the bottom of the axle back may be required.
15. Reinstall shocks
16. Reinstall wheels
17. Carefully lower vehicle onto ground
18. Torque wheels, shocks and control arm bolts to factory specifications



## EVO-1046 EVO 44 Magnum Sealed Axle Sleeves



	QTY	PART#	DESCRIPTION
<input type="checkbox"/>	1	EVO-20012	Driverside Axle Sleeve JK Dana 30/44
<input type="checkbox"/>	1	EVO-20013	Pass Axle Sleeve JK Dana 30/44
<input type="checkbox"/>	1	EVO-301	Magnum Seal Pack
<input type="checkbox"/>	2	EVO-900235	Metric Flush Style Grease Fitting(Assembled)

**By purchasing this kit you are starting the next level of performance. To install this kit it requires work and finesse. Drilling, Welding, and Grinding required; not bitching and moaning. This is a toy, it should be fun!**

**These 44 Magnum Sealed Axle Sleeves are intended to increase strength of the axle housing. The seal surface is designed to help prevent rocks, dirt and debris from entering the tube.**

**Through our extensive testing, different JK's years and models, we noticed a large variance in axle tube inner diameter deformation caused by a number of factory manufacturing processes, welding on spring perches, axle C's etc. Due to this variance and burrs from drilling the holes, we specifically designed the 44 Magnum sealed axle sleeves to have a slip fit with little to no need to be forced into place. The plug welds are more than sufficient to support the added strength.**

**Caution: This kit requires welding. Welding creates a very bright arc that should not be looked at without an approved protective shield/clothing. Welded surfaces and areas in their vicinity will be very hot for a long period of time after welding. Please use caution. All welding should be performed by a professional.**

1. Elevate front of vehicle securely by frame, fully extend suspension.
2. Remove front wheels.
3. Remove front brake calipers
4. Remove 3 bolts holding front axle shaft to the turning knuckle, both sides. Removing tie-rods and drag link may aid in removing these bolts.
5. Disconnect wheel speed wire from knuckle.
6. Remove axle shafts.
7. With a rag and brake clean or other solvent/degreaser, clean inside of axle tubes of debris.
8. On passenger side, mark 6 holes on bottom of axle tube equally spaced. 5 holes on one side of control arm and one hole on other side of control arm, close to axle C.
9. Mark 3 holes equally spaced on top side of passenger axle tube, one at C.
10. Mark hole on back side of passenger axle tube close to axle C.
11. On driver side axle tube, mark one hole on top of axle tube 1" away from center housing.
12. On driver side axle tube, mark two holes under spring perch as close to top of tube as possible.
13. On driver side axle tube, mark three holes on bottom of tube, one 1" from housing through control arm pocket, one 1" center of axle tube and one 5" from axle C.
14. On driver side tube top of axle tube, mark one hole 1" from housing, one hole under spring perch as close to top as possible and one .5" from axle C.
15. Mark two holes equally spaced on front of axle tube.
16. Mark on hole on back of axle tube next to C.
17. Center punch center of all marked holes.

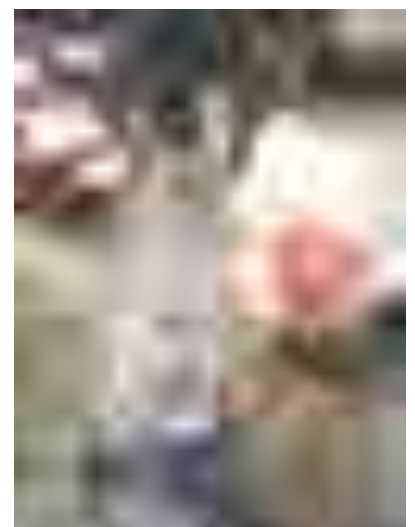

18. With a clean rag, securely tie a string or wire to the rag. String should be 36+” long.
19. Using a long dowel push clean rag all the way into tube up against inner seal with string. Do this in both axle tubes.
20. Drill all marked holes with a 1/2” drill. Drilling all holes with a smaller, 1/4” drill bit first before drilling larger hole will ease the drilling process.
21. After all holes have been drilled. Pull on string, slowly removing rag from axle tube. This will remove all drill shavings.
22. With a flashlight look into axle tubes to make sure all shavings and debris is removed. Clean if required.
23. Slide 44 Magnum tubes into housing. Long magnum on passenger side. Short magnum on driver side.
24. Insert sleeves on both sides until the zerk fitting is just about to stop the sleeve from going in any further (pretty much all the way in until machined step). Make sure zerk fitting is able to be greased with a needle fitting.
25. Rotate 44 magnums, so that zerk fitting is facing forward.
26. Recommended: Tack sleeve in place and reinstall axles and unbearing checking for free rotation. If free remove axle and bearing.
27. Weld all drilled holes fully and completely around end of tubes. **Weld all holes on bottom of axle tube first, and then proceed to weld the rest.** Do not weld zerk fitting.
28. Let weld cool before installing seals and paint.

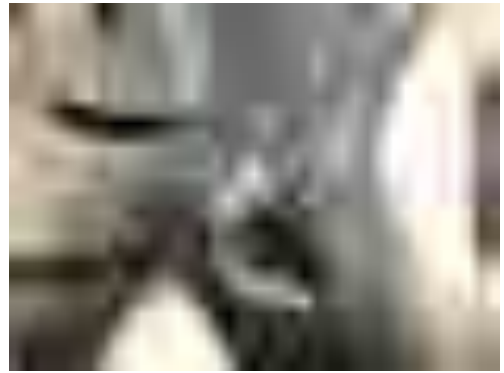

29. Install seals as shown. Install all seals dry.  
Dana 44 Axle (Rubicon Models): Use Black O-rings inner most groove, Large inner diameter felt seal on outer most groove  
Dana 30 Axle (X, and Sahara Models): Use inner small diameter felt seal on inner groove and large diameter felt seal on outer groove.  
Aftermarket Axle shafts: Use Dana 44 Seal instructions for both Dana44 and Dana30



30. Make sure felt seals are fully pressed into grooves on both side of seals. Pack all seals with grease.
31. Fully clean axle shafts.
32. Grease splines on axle shaft.
33. Using grease or spray lubricant, lubricate entire axle shaft liberally.
34. Install axle shaft into 44 Magnum's **rotating axle shaft**. Rotate axle shaft through entire length until fully seated at knuckle.
35. Reinstall the wheel speed wire.
36. Reinstall 3 bolts holding axle shaft to knuckle. Torque to factory specifications
37. Reinstall brake rotor and caliper. Torque to factory specifications
38. Using a needle zerk fitting on your grease gun, give seals 2-3 pumps on each side. These seals should be greased every oil change.
39. If removed, reinstall drag link and tie rod and use a new cotter pin where applicable. Torque to factory specifications.
40. Reinstall wheels and tire. Torque to factory specifications.







## **EVO-1047 JK Rock Skins (Steel/ Aluminum)**



**Nutsert tool / Thread insert tool can be found online at such places as Amazon, Harbor Freight, and many other tool supply companies web sites.**

**Caution: This kit requires drilling into the body of your vehicle. Make sure the RockSkin follows the bodyline of your vehicle before installing.**

1. Line entire outer edge of inner side of rockskin, both driver and passenger side with masking tape.



2. Hold RockSkin up to driver side.
3. Align RockSkin with bodylines on the vehicle.
4. Using the RockSkin as a template, mark the center of the holes that are in between the driver and passenger door on 4 Door Models and the 3 holes below the center of the driver door on 2 Door Models.
5. Verify that no wires are in the way of holes to be drilled. Drill all holes with 3/8" drill. Only drill through outer portion of sheet metal.



6. From hardware pack EVO7700011/7700012, Insert the nutserts into the 3/8" drilled holes with the flange side out until the flange is fully seated against the fender. This may require a light tap with a hammer/mallet to fully insert.

7. Fully thread the long 1/4" bolt with nut into the nutsert as seen in photo. With wrenches hold the bolt stationary and turn the nut 2 - 3 turns making sure that the nutsert does **NOT** turn. (There are tools specifically designed for installing these nutserts. Please call for more information if you would like information on where to purchase this tool)



8. Install the RockSkin on the Driver side with the inserts that were installed in center of the vehicle and the supplied ¼-20 stainless flat head bolts.
9. Using a clamp or another set of hands, pull the RockSkin in towards the body on the rear of the vehicle making sure the bodylines stay aligned.
10. Mark center of the holes on the rear portion of center.
11. Using a clamp or another set of hands, pull the RockSkin in towards the body on the front of the vehicle making sure the bodylines stay aligned.
12. Mark center of the holes on the front portion of center.
13. Remove RockSkin from vehicle.
14. Repeat steps 5-7 on all marked holes.
15. Remove tape on RockSkin
16. Place a bead of RTV silicone (for example, "The Right Stuff") around the entire perimeter of the RockSkin, bolt holes and logo's.
17. Install RockSkins to all installed Nutserts with supplied ¼-20 Stainless FlatHead Screws.
18. Repeat all steps on Passenger Side
19. Reinstall factory sliders or aftermarket frame mounted slider.



## EVO-1048 EVO MFG Rocksliders 2D/4D

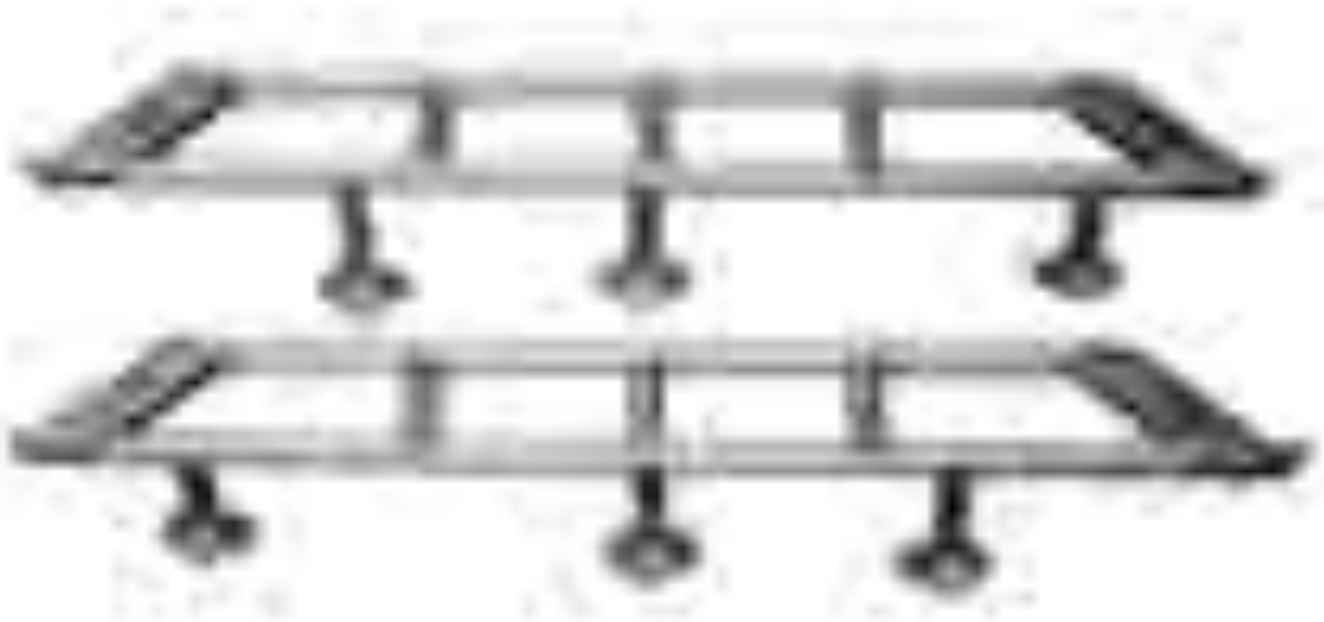

EVO-1048-2D / EVO-1048-4D

---

<input type="checkbox"/>	QTY	PART#	DESCRIPTION
<input type="checkbox"/>	1	EVO-11027 / EVO-11025	2dr.ROCKSLIDER Driver/ 4dr. ROCKSLIDER Driver
<input type="checkbox"/>	1	EVO-11028 / EVO-11026	2dr. ROCKSLIDER PASS/ 4dr. ROCKSLIDER PASS

**The EVO MFG RockSliders are intended to be welded onto your vehicle wherever you prefer, up if you have a body lift down if you don't, forward if you have large tires etc. This is one of the advantages of a weld-on slider other than their increased strength. Test fit sliders before painting or coating.**

**A few things the installer should take into account before welding**

**Make sure you have a .5" (~thumb width) or more between the pinch seam of the body and the rockslider at all three frame tubes.**

- Sand paint from all areas to be welded
- Repaint all exposed metal after welds cool
- Disconnect the terminals on your battery at all times while welding on the vehicle.



**Shown with optional EVO RockSkin body protection, available for both 2 Door and 4 Door Models**



## **EVO-1050 JK Long Arm Upgrade w/ EVOlever**



**Recommended: All Vehicles that spend time on salted roads. It is recommended that removal of both threaded collar and joint on all arms. Apply a small amount of Anti Seize on threads and reassemble.**

**2010 and newer JK requires exhaust modifications. 2012 or Newer: Exhaust modifications required on front exhaust loop.**

	QTY	PART#	DESCRIPTION
<input type="checkbox"/>	1	<b>EVO-760009</b>	<b>BOX#1 40X9X9</b>
<input type="checkbox"/>	2	EVO-11060B	31LA Tube Steel Front Lower JK
<input type="checkbox"/>	2	EVO-11061B	27LA Tube Steel Rear Lower JK
<input type="checkbox"/>	1	<b>EVO-760009</b>	<b>BOX#2 40X9X9</b>
<input type="checkbox"/>	1	EVO-11035B	Rear Upper LA, DRIVER BLK
<input type="checkbox"/>	1	EVO-11036B	Rear Upper LA, PASS BLK
<input type="checkbox"/>	1	EVO-11037B	Front Upper LA DRIVER BLK
<input type="checkbox"/>	1	EVO-11038B	Front Upper LA PASS BLK
<input type="checkbox"/>	1	<b>EVO-760009</b>	<b>BOX#3 40X9X9</b>
<input type="checkbox"/>	1	EVO-11047	Driver Rear LA Control Arm Bracket
<input type="checkbox"/>	1	EVO-11048	PASS Rear LA Control Arm Bracket
<input type="checkbox"/>	1	EVO-11049	Driver Front LA Control Arm Bracket
<input type="checkbox"/>	1	EVO-11050	PASS Front LA Control Arm Bracket
<input type="checkbox"/>	1	EVO-1045	3 Degree Axle Mount
<input type="checkbox"/>	4	EVO-10003-7	Shock Tab, Canti Sub-frame
<input type="checkbox"/>	2	EVO-10003- 8Alt	10003-8Alternative
<input type="checkbox"/>	1	EVO-770024	LA Upgrade HARDWARE Pack
<input type="checkbox"/>	4	EVO-100563263	Misalignment Spacer
<input type="checkbox"/>	2	EVO-11005CZ	JK Rear Upper Bolt Tab LA
<input type="checkbox"/>	2	EVO-11006CZ	JK Rear Lower Bolt Tab LA
<input type="checkbox"/>	8	EVO-900023	HHCS 3/8-24 x1.50 GrC Zinc
<input type="checkbox"/>	8	EVO-900221	Stover Lock Nut 3/8-24 GrC Zinc
<input type="checkbox"/>	2	EVO-900286	Black-Phosphate Internal Retain
<input type="checkbox"/>	4	EVO-900325	HHCS M12, 130MM, 1.75MM, Partial Thread

**NOTE: 2012+ model JK's use 4qty EVO-900325 (HHCS M12, 130mm, 1.75mm Partial Thread 8.8 Zinc ) Cross Member Bolts**

1. Elevate the vehicle securely.
2. Secure axles on adjustable jack stands
3. Remove bolts retaining brakeline brackets from frame
4. Remove front and rear shocks
5. Remove front and rear swaybar endlinks
6. Remove front and rear springs
7. Mark and cut Front factory control arm brackets as shown on lines in above photos. Removal of the inner portions are only required. Lower front factory brackets need to be trimmed as shown leaving the outer factory portion of the bracket remaining on the vehicle.
8. Support transmission cross-member with adjustable jack stand. Remove two bolts on passenger side that hold in cross-member.
9. Install front passenger side brackets as shown.
10. Reinstall transmission bolts just as factory through new front control arm brackets
11. Install supplied ½" bolt at factory lower control arm tab toward front of vehicle.

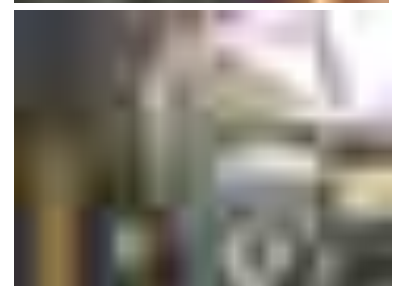
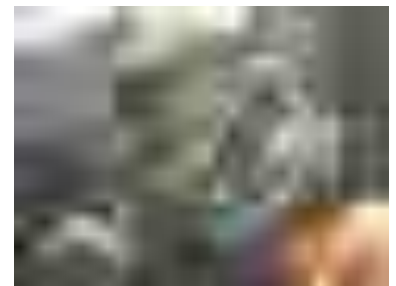

12. Drill 3/8" hole in front side of factory transmission cross-member
13. Through access hole on underside of cross-member install 3/8" bolt, nut and washer through supplied control arm bracket to transmission cross-member.

Repeat steps on driver side.

Weld all control arm brackets to frame in all locations they touch

the frame top and bottom. DO NOT weld toward the center of bracket that touches the removable factory transmission cross-member.

14. Install front control arms upper and lower using factory hardware on factory mounting locations and supplied hardware on EVO Brackets. Front lowers starting length 34.5" and upper starting length 26.375", roughly fully threaded in. **FRONT UPPER ARMS SHOULD HAVE THE BEND OF THE ARM MOVING AWAY FROM THE FRAME ON BOTH DRIVER AND PASS SIDES.**

15. Front upper control arm mounts at the frame will have the bolt inserted from the ground up. Not left to right.

**Rear:**

16. Remove all rear factory control arm brackets as shown in lines on photos. All rear control arm brackets need to be removed and grinded flush to the frame.
17. Carefully remove gas tank from vehicle. This can be heavy depending on fuel level. Be very careful as this contains highly flammable gasoline. Store in a safe place.
18. Cut rear body mount as shown in photo. The rear most tab of the body mount needs to be trimmed all the way to the top. Grind all cuts smooth to frame.
19. Paint all exposed metal.
20. Remove two factory body mount bolts. The two outer small ones.
21. Install driver and pass side brackets on frame.
22. Tighten two body mount bolts to factory specifications.
23. Mark center of all the two control arm holes, 9/16", and drill through outer frame side only.

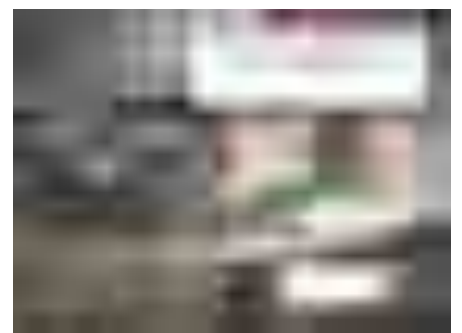
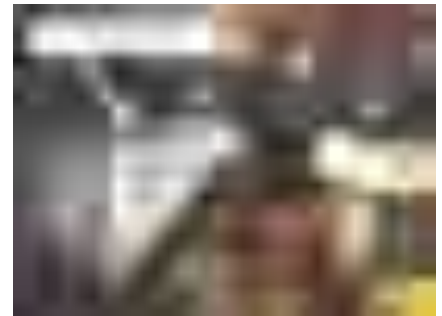
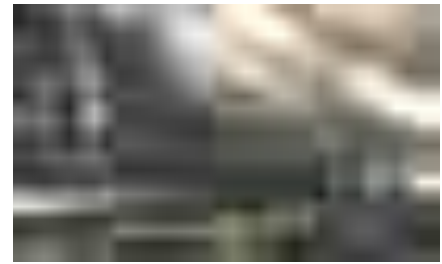



24. Driver side will need a square hole cut into frame (same as the hole on the frame on passenger side). This is for nut access for the driver side rear lower arms. Use bracket as template for cut. Use plasma cutter or drill corners of square with drill and complete the straights of the square with cut off wheel.



25. Reinstall brackets to body mounts if removed and weld all edges of the brackets completely to frame inside and out.

26. Paint all bare metal.

27. Reinstall gas tank to its factory location using factory hardware. Be extremely careful in doing so, no flames, sparks or cutting etc at this time.

28. Cut off rear lower control arm bracket on the axle and grind smooth to axle tube.

29. Install rear upper and lower control arms into all remaining control arm mounts on axle and frame. Rear lower mounts at axle will not exist at this time. Use small nut plate with bend for rear lower arm nuts at frame through the square holes and longer nut plates for rear upper nuts at frame through factory small square access hole on underside of frame.

30. Adjust rear lower control arms to 30.5" from center to center and uppers to 20.5" center to center. Roughly fully threaded in...

31. Install rear EVO axle bracket onto remaining control arm joints with factory hardware. Hold up to axle tube where control arm bracket once was.

32. Set pinion angle on vehicle so that the driveshaft and the pinion are inline within 3 degrees with the axle at an approximate right height and centered to vehicle.

33. With rear wheels and tires installed pivot lower control arm to axle tube and move outward on axle tube while radius on brackets are still around tube until the rear control arms and the inner sidewall of the tire are 1.0" apart. Tack new lower control arm mounts into place on axle tube. Roughly ends of brackets will be close the end flanges on the axle tube ends.

34. Thick rear swaybar tab should be installed on outside sheet metal edge of factory bumpstop pad and straight rearward of tube. Tack into place.



35. If installing with EVOlever or rear DTD. There are 4 smaller tabs that will be used for the new limit strap location. 2 per strap, one on each side of strap tab. They should be installed and tacked into place in line with tabs on subframe above, straight off the back of the axle tube. When cycling later on, make sure shocks do not contact subframe at full droop/extension. If so, rotate tabs lower on axle tube and slightly inward until no contact is made of shocks to subframe.

36. Weld on all axle brackets/tabs to axle once axle has been cycled up and down and verification is made that all components clear each other.

37. Cycle front and rear suspension up and down while turning front tires left and right to verify no interference with any components and that all wires, hoses etc are clear and are long enough.

38. Very carefully set vehicle back on ground

39. Torque all suspension bolts to factory specifications including wheels

**2012 or Newer:** Exhaust modifications required on front exhaust loop. Custom exhaust fabrication or below required. Exhaust loop needs to be cut perpendicular to floor straight through factory exhaust loop on both the forward side of the loop and rearward near coupling flange. The loop then needs to be flipped 180 so that the previous front is now welded to the rear and vice versa. Rotate and make sure loop clears front upper control arm bracket and arms before fully welding around to reconnect to exhaust system.



Size	Recommended Torque											
	Grade 2		Grade 5		Grade 8		18-8 S/S		Bronze		Brass	
	Coarse	Fine	Coarse	Fine	Coarse	Fine	Coarse	Fine	Coarse	Fine	Coarse	Fine
<b>#4*</b>	-	-	-	-	-	-	5.2	-	4.8	-	4.3	-
<b>#6*</b>	-	-	-	-	-	-	9.6	-	8.9	-	7.9	-
<b>#8*</b>	-	-	-	-	-	-	19.8	-	18.4	-	16.2	-
<b>#10*</b>	-	-	-	-	-	-	22.8	31.7	21.2	29.3	18.6	25.9
<b>1/4</b>	4	4.7	6.3	7.3	9	10	6.3	7.8	5.7	7.3	5.1	6.4
<b>5/16</b>	8	9	13	14	18	20	11	11.8	10.3	10.9	8.9	9.7
<b>3/8</b>	15	17	23	26	33	37	20	22	18	20	16	18
<b>7/16</b>	24	27	37	41	52	58	31	33	29	31	26	27
<b>1/2</b>	37	41	57	64	80	90	43	45	40	42	35	37
<b>9/16</b>	53	59	82	91	115	129	57	63	53	58	47	51
<b>5/8</b>	73	83	112	128	159	180	93	104	86	96	76	85
<b>3/4</b>	125	138	200	223	282	315	128	124	104	102	118	115
<b>7/8</b>	129	144	322	355	454	501	194	193	178	178	159	158
<b>1+</b>	188	210	483	541	682	764	287	289	265	240	235	212



## EVO-1060S

### EVO MFG Rear RockStop Kit



	QTY	PART#	DESCRIPTION
<input type="checkbox"/>	1	EVO-10056-1	Rear Rockstop Plate DRVR
<input type="checkbox"/>	1	EVO-10057-1	Rear Rockstop Plate PASS

**Caution: This kit requires welding and cutting into the frame of your vehicle. Welding creates a very bright arc that should not be looked at without an approved protective shield/clothing. Welded surfaces and areas in their vicinity will be very hot for a long period of time after welding. Please use caution. All welding and cutting should be performed by a professional.**

1. Support Vehicle Securely/Safely
2. Remove tires
3. Remove factory rear bumpstops
4. Remove rear shocks
5. Remove rear swaybar endlinks from axle
6. Remove rear springs
7. Completely cut/sand down factory frame bracket where original bumpstop was once mounted
8. Using supplied EVO bracket place over frame
9. Completely compress rear axle until bump pad on axle is approximately 2" from frame, retain all aftermarket bumpstop spacers on axle



10. Line up the bumpstop in bracket and center plate and bumpstop in bracket centered up on bumpstop pad on axle.
11. Mark edges of bracket including the center edges where bumpstop is to be placed with pen/paint marker for alignment.



12. Using a torch, plasma cutter or sawzall cut the center marks where airbump is going to go of the brackets on both passenger and driverside.  
**Make sure that placement is correct and DO NOT cut completely through the frame, follow contour of bracket. Make sure that there is no wires or other items in way of cut or near.**



13. Reinstall bracket around frame rail inline with cut/marks and place bumpstop in correct position inside cut/bracket.
14. Bumpstop metal tube, for most applications should be as high in the bracket as possible with just enough room weld along the bottom of the tube to the EVO bracket. This will vary between applications.
15. Tack weld brackets and plate into place.

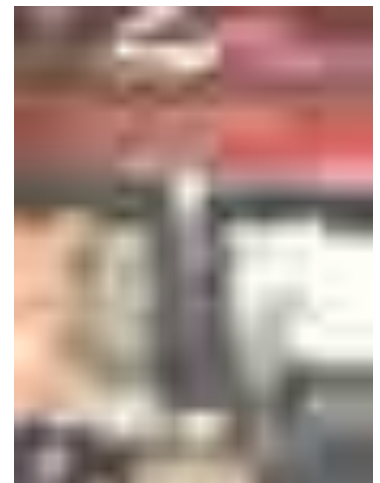

16. With airbumps installed in can, Cycle suspension with tires on and off up and down and make sure this is the correct location and nothing is making inappropriate contact. This is your last chance to make sure it is correct.



17. Once deemed correct location, remove airbumps, weld completely around brackets on frame and onto airbump tube.
18. Paint all exposed metal
19. Install airbump into metal tube. This may require a small amount of sanding to the inside of the tube to install bumpstop.



#### **EVOlever/DTD Installs Only:**

Will require you to install the EVOlever frame mounted trackbar bracket just as normal. This will allow for the correct location of the trackbar. Once installed as normal cut as shown in photo. Then install the rest of the brackets of the airbump kit as stated above. \*\*\* For this application bumpstop extension will need to be added to the axle making this the same as the driver side extension. Can be purchased separately. EVO-10082





EVO Manufacturing

Jeep Wrangler JK/JKU

JK/JKU Enforcer Suspension Kit

EVO-1063, 230





Before starting installation procedure please read <http://evomfg.com>Returns-Warranties-Shipping>

---

**CAREFULLY READ AND FOLLOW ALL INSTRUCTIONS IN THIS MANUAL AND KEEP FOR FUTURE REFERENCE. IF YOU HAVE ANY QUESTIONS ABOUT THE PRODUCT CALL EVO MANUFACTURING. FAILURE TO FOLLOW GUIDELINES COULD RESULT IN MALFUNCTION OF PARTS OR INJURY. PLEASE HAVE A TRAINED PROFESSIONAL ASSIST WITH OR INSTALL ALL PRODUCTS. INSTALLING EVO MFG PRODUCTS OR KITS DEMANDS SPECIFIC KNOWLEDGE, TOOLS AND EXPERIENCE. GENERAL KNOWLEDGE OF HOW TO USE LATER SPECIFIED TOOLS AND/OR LIMITED EXPERIENCE WITH EVO MFG PRODUCTS MAY NOT BE ENOUGH TO PROPERLY COMPLETE THESE TASKS. SOME OF EVO MFG PRODUCTS MAY REQUIRE TWO OR MORE PEOPLE TO INSTALL SAFELY AND CORRECTLY. DO NOT ATTEMPT ALONE, ALWAYS ENLIST THE HELP OF TRAINED PROFESSIONAL WHEN NEEDED.**

**READ BEFORE INSTALL:**

- All models will require wheels spacers or aftermarket wheels with 4.5" or smaller number backsacing.
- All factory bolts should be tightened to factory specifications.
- All supplied bolts torqued according to chart at end of instruction.
- It is recommended all installation be performed by a trained professional.
- Some modification may have to be done in order to fit preferred tire or tire brand/size.
- Loosely install all bracket hardware, do not tighten until all hardware is installed.
- Cutting/grinding/clearance is required to complete installation.
- After market CV drivelines are recommended.
- Welding on rear trackbar bracket is recommended after installation.





**If installing EVO MFG Enforcer Control Arms:**

**FRONT UPPER CONTROL ARMS STARTING LENGTH CENTER TO CENTER**

**Starting length 3<sup>3</sup>/<sub>4</sub>" Lift: 18 <sup>3</sup>/<sub>4</sub>"**

**FRONT LOWER CONTROL ARMS STARTING LENGTH**

**Starting Length 3" Lift: 23"  
Starting Length 4" Lift: 23 1/8"**

**REAR UPPER CONTROL ARMS STARTING LENGTH**

**Starting Length 3<sup>3</sup>/<sub>4</sub>" Lift: 18"**

**REAR LOWER CONTROL ARMS STARTING LENGTH**

**Starting Length 3<sup>3</sup>/<sub>4</sub>" Lift: 19 <sup>3</sup>/<sub>4</sub>"**

**IF INSTALLING ALL 8 CONTROL ARMS (STAGE 4) THEN ADD <sup>1</sup>/<sub>4</sub>" TO ALL STARTING MEASUREMENTS**

All Vehicles that spend time on salted roads. It is recommended that removal of control arm joint (threaded one) on all EVO control arms before installation of vehicle. Apply a small amount of Anti Seize on threads and reassemble.

After alignment is complete and no additional adjusts are to be made to control arms. Torque all 1" Jam Nuts to 250 ft/lbs and all 1-1/4" Jam Nuts torque to 300 ft/lbs. Regularly check all jam nuts and punch bolts on all Enforcer control arms for proper torque/tightness. Failure to do so may cause premature wear of threads on arms.

Keep all mounting bolts loose (installed but not torqued) we will torque later at the end of complete installation.

ALL measurements stated above are starting points only, every vehicle is different. Professional alignment is recommended.

Keep all control arm mounting bolts loose (installed but not torqued) we will torque later at the end of installation

Align to factory specifications. Recommended caster 5 Degrees +/- .5





Parts included: Table below shows JK/JKU Enforcer Suspension Kits.

Description	#	Part #	Quantity
Box #1	1	EVO-760008	1
Evo Front Lower Driver Control Arm	2	EVO-11022B	1
EVO Front Lower Pass Control Arm	3	EVO-11023B	1
Rear Trackbar Bracket	4	EVO-10080B	1
Rear Trackbar Bracket Hardware Pack	5	EVO-7700021	1
3" Front Bumpstop Spacer	6	EVO-20005	2
Thread Cutting Tool	7	EVO-900333	2
Rear 3"/4" Bumpstop Bracket	8	EVO-10081B/10082B	2
HHCS 5/16-24 x 0.75	9	EVO-900281	4
SAE Washer 5/16"	10	EVO-900213	8
Stover Lock Nut 5/16"	11	EVO-900220	4
Brake Line Kit	12	EVO-600067	2
Swaybar Link	13	EVO-12029B	2
Bushing B/O C/O	14	EVO-600077	4
Swaybar Bushing Tube	15	EVO-20032	4
EVO Shock Mount Hardware	16	EVO-770008	1
Box #2	17	EVO-760015	1
3"/4" Front Plush Ride Spring	18	EVO-600075/600037	2
Box #3	19	EVO-760015	1
3"/4" Rear Plush Ride Springs	20	EVO-600076/600038	2





#### **Recommended Tools:**

- Allen set
  - Wrenches (English/Metric)
  - Vehicle Jack
  - WD40
  - Rubber Mallet
  - Thread Lock
  - Grinder
  - Impact with standard sockets
  - Sawzall/Cut off wheel or similar
  - Drill and ½" bit
- 



#### Safety Steps for installation

- For installing EVO MFG products always use wheel chokes to block rear tires from rolling.
  - Always make sure you have everything necessary ready before install.
  - If you have to, carefully lift front of vehicle by front frame rails extending suspension until tires leave the ground, place frame on approved jack stands for vehicle. Verify all lines/wires are not over extended.
  - Remove tires if needed for easier install.
  - Make sure to wear safety equipment (eye protection, hand protection, foot protection etc.) at all times during installation.
  - Make sure all safety precautions have been taken.
  - Always check and replace any part of vehicle that is worn or broken before starting install.
  - Do not mix anything EVO with weaker alternatives.
  - It is generally a good idea to apply liquid threadlock to all bolts.
  - Tighten included hardware to torque specifications in bottom table unless it is otherwise specified, factory bolts should be torqued to factory Jeep specifications.
- 





## INSTALL

1. Park vehicle on level ground.
2. Elevate front of vehicle securely and safely until tires leave ground.
3. Safely and securely support front frame of vehicle on adjustable jack stands
4. Remove front wheels/tires
5. Remove front swaybar links from vehicle
6. Remove brakeline mounting bolt at frame on both driver and passenger side. **Do not disassemble brakeline itself.**
7. Remove front shocks
8. Remove front springs
9. Working on the driver side first, remove factory lower front control arm



10. Install Supplied EVO Front control arms on driver side with zerks fitting on both ends facing upwards.

The lower arms should bend towards the center of the vehicle. The bend points upwards on upper arms.

11. Torque both bolts to factory specifications. Repeat previous steps on passenger side.

**Note:** Do not remove more than one control arm at a time, uninstall 1 control arm and replace it with EVO arm, then move on to next arm.



12. On both driver and passenger side, drill a 5/16" hole in the center of the spring mount on axle.

13. Using supplied self threading bolt, place the bumpstop extensions over the drilled hole on the axle and thread through the center the self threading bolt on both driver and passenger sides

14. Install front coil springs on both driver and passenger sides, smaller pigtail end of spring should be at the frame side (top) with the factory coil spring rubber isolator retained at the top. Make sure lower mount is placed properly into the coil retaining location on the axle





15. Install front shocks top end first (studded end) with one rubber part on the top and one rubber part on the underside of the frame mount.
16. Slowly and carefully raise the axle until the driver side shock mount is line up with the factory axle hole. Install bolt and torque to factory specifications
17. Repeat previous step on passenger side

18. Install supplied brakelines. Cut the thin support tie holding your brake line and ABS line together, separate the main plastic coupling holding your brake line and ABS lines together, Using an 11mm wrench, separate the hard line from the bracket/hose, using a 10mm socket, remove the bolt securing the bracket/hose to the frame rail and set aside the bolt for later use, Use a 10mm socket to secure your new stainless steel brake line mounting bracket to the frame rails using the factory bolt, using a 15mm socket, remove the banjo bolt securing your brake line to it and set it aside, Slip your new stainless steel brake line up through the new mounting bracket and then fasten the hard line to it using a 12mm and 17mm wrench, slip one of the new copper crush washers on to the factory banjo bolt, Insert the factory banjo bolt with copper crush washer on through the new stainless steel brake line and then slip on another copper crush washer, Using a 15mm socket, secure your new stainless steel break line to the break caliper, tighten the banjo bolt to 276 in. lbs. of torque (hard line elbow extends out and back).
19. Secure your new stainless steel brake line to the mounting bracket using the retaining clip, attach your new stainless steel brake line and ABS wiring together using the factory main plastic coupler, zip-tie your new stainless steel brake line and ABS together as they were before, check the fluid level in your master cylinder.

20. Install new wheels, torque lug nuts to factory specifications
21. Turn wheels full left and full right making sure all wires, brakelines and hoses are free from contact on any component.
22. Carefully lower front of vehicle onto ground



## **REAR INSTALL**

23. Elevate rear of vehicle securely and safely until tires leave ground.
24. Safely and securely support rear frame of vehicle on adjustable jack stands
25. Remove rear wheels/tires
26. Remove rear swaybar links from vehicle, these will be installed on the front lateron.
27. Remove brakeline mounting bolt at frame on both driver and passenger side.
28. Remove rear shocks
29. Remove rear springs
30. Remove rear parking brake cables from mounting bracket on floorboard of vehicle.
31. Remove rear trackbar bolt at axle, leave trackbar bolt at frame installed

32. Install Supplied EVO rear control arms on driver side with zerk fitting on both ends facing upwards.

The upper arms should bend towards the center of the vehicle.

33. Torque both bolts to factory specifications. Repeat previous steps on passenger side.

**Note:** Do not remove more than one control arm at a time, uninstall 1 control arm and replace it with EVO arm, then move on to next arm.



34. Cut factory rear trackbar as shown.  
Only remove the rear most part of  
the bracket.

---



35. Sand all cuts smooth with flat  
mounting plate.

---





36. Install rear trackbar bracket as shown with supplied 9/16 bolt and ubolts.

37. Weld on rear trackbar bracket to axle where ever possible, see photo



38. Reinstall trackbar into new higher location with factory bolt. (torque to factory specifications once vehicle is on ground and at ride height.)

39. Install shocks in upper mounts with supplied bracketry and hardware







40. Install springs into lower axle mount, smaller end of spring should be mounted on the axle side. Larger end of spring goes up while retaining the factory rubber coil spring isolator
  41. Slowly and carefully raise axle until lower shock mounts line up with axle mounting bolt holes. Make sure upper coil springs and isolators are properly centered in coil spring perches on top and bottom
  42. Install shocks bolts at axle
- 



41. Install rear brakelines Using a 15mm socket remove the banjo bolt from caliper, Remove the banjo bolt from the brake hose, remove the copper washers and keep them aside you will need to reuse them. Using an 11mm wrench, separate the hard line from the bracket/hose, using a 10mm socket, remove the bolt securing the bracket/hose to the frame rail and set aside the bolt for later use. Install new copper crush washers on to the factory banjo bolt, Insert the factory banjo bolt with copper crush washer on through the new stainless steel brake line, then slip another copper crush washer on. Using a 15mm socket, secure your new stainless steel break line to the break caliper, tighten the banjo bolt to 276 in. lbs. of torque (hard line elbow extends out and back).
42. Use a 10mm socket to secure your new stainless steel brake line mounting brackets to the frame rails using the factory bolts, Slip your new stainless steel brake line up through the new mounting bracket, fasten the factory hard line to it using a 12mm and 17mm wrench, Secure your new stainless steel brake line to the mounting bracket using the retaining clip, Check the fluid level in your master cylinder. Bleed brakes following factory procedure.



43. Install Swaybar bushings into supplied swaybar links, use of a lubricant and a small hammer will assist in this process, install swaybar endlink tubes into swaybar bushings. Install supplied EVO Endlinks into swaybar and axle mounts on both driver and passenger side rear.

---



44. Install rear bumpstop extensions on axle with supplied 5/16" hardware
45. Install new wheels and carefully lower vehicle onto ground.
46. Install the factory rear swaybar endlinks on the front of the vehicles swaybar.
47. Torque lug nuts to factory specifications
48. Torque all bolts to factory specifications
49. Retorque all hardware after 500 miles and every off road trip.

After install, set pinion angle on vehicle so that the driveshaft and the pinion are inline within 3 degrees with the axle at an approximate ride height and centered to vehicle.

---





After Install:

- Tighten all bolts securing purchased parts to specified locations.
- After completing installation using provided instructions, go through all steps again to make sure nothing was missed, not tightened or improperly assembled.
- Some components may need to be purchased separately.
- Check turn signals, headlights, fog lights (if applicable), taillights, blinkers and windshield wipers.
- Adjust mirrors, speedometer and headlights if needed.
- Make sure all gauges are fully operational.
- Drive the vehicle slowly for a couple minutes, looking and listening for abnormal noises while driving. After modification of a vehicle there will be differences in driving experiences and capabilities, be mindful of that.
- Inspect and Retorque all Bolts after 500 miles of completed installation and regularly thereafter.
- Some modification may be required.

Recommended Torque:

Size	Grade 2		Grade 5		Grade 8		18-8 S/S	
	Coarse	Fine	Coarse	Fine	Coarse	Fine	Coarse	Fine
<b>#4*</b>	-	-	-	-	-	-	5.2	-
<b>#6*</b>	-	-	-	-	-	-	9.6	-
<b>#8*</b>	-	-	-	-	-	-	19.8	-
<b>#10*</b>	-	-	-	-	-	-	22.8	31.7
<b>1/4</b>	4	4.7	6.3	7.3	9	10	6.3	7.8
<b>5/16</b>	8	9	13	14	18	20	11	11.8
<b>3/8</b>	15	17	23	26	33	37	20	22
<b>7/16</b>	24	27	37	41	52	58	31	33
<b>1/2</b>	37	41	57	64	80	90	43	45
<b>9/16</b>	53	59	82	91	115	129	57	63
<b>5/8</b>	73	83	112	128	159	180	93	104
<b>3/4</b>	125	138	200	223	282	315	128	124
<b>7/8</b>	129	144	322	355	454	501	194	193
<b>1+</b>	188	210	483	541	682	764	287	289



## EVO-1063 JK Enforcer System



QTY	PART#	DESCRIPTION
<input type="checkbox"/>	1	<b>EVO-760008</b> <b>BOX#1 32x10x6.5</b>
<input type="checkbox"/>	1	EVO-11022B EVO Front Lower Control Arm, Driver
<input type="checkbox"/>	1	EVO-11023B EVO Front Lower Control Arm, Pass
<input type="checkbox"/>	1	EVO-10080B Rear Trackbar Bracket
<input type="checkbox"/>	1	EVO-7700021 Rear Trackbar Bracket HARDWARE Pack
<input type="checkbox"/>	2	EVO-20005 3" Front Bumpstop Spacer
<input type="checkbox"/>	2	EVO-900333 Thread Cutting Screw Metal/ Plastic
<input type="checkbox"/>	2	EVO-10081B/EVO-10082B Rear 3"/ 4" Bumpstop JK BLK
<input type="checkbox"/>	4	EVO-900281 HHCS 5/16-24 x 0.75
<input type="checkbox"/>	8	EVO-900213 SAE Washer 5/16 Thru Hardend Zinc
<input type="checkbox"/>	4	EVO-900220 Stover Lock Nut 5/16-24 GrC Zinc
<input type="checkbox"/>	2	EVO-600067 Brakeline Kit
<input type="checkbox"/>	2	EVO-12029B Swaybar Link BLK
<input type="checkbox"/>	4	EVO-600077 Bushing B/O C/O
<input type="checkbox"/>	4	EVO-20032 Swaybar Bushing Tube
<input type="checkbox"/>	1	EVO-770008 EVO Shock Mount Hardware
<input type="checkbox"/>	1	<b>EVO-760015</b> <b>BOX#2 24x12x6</b>
<input type="checkbox"/>	2	EVO-600075/ EVO-600037 3"/ 4" Front Plush Ride Spring
<input type="checkbox"/>	1	<b>EVO-760015</b> <b>BOX#3 24x12x6</b>
<input type="checkbox"/>	2	EVO-600076/EVO-600038 3"/ 4" Rear Plush Ride Spring

NOTES: Cutting and grinding is required to complete the installation of the rear roll center correction trackbar bracket. Wheel spacers or aftermarket wheels with a smaller backspacing than factory (4.5" or smaller number are recommended) are required for a complete installation. Aftermarket CV drivelines are recommended. Welding on rear trackbar bracket is recommended after installation. **Recommended: All Vehicles that spend time on salted roads. It is recommended that removal of both threaded collar and joint on all arms. Apply a small amount of Anti Seize on threads and reassemble.**

1. Park vehicle on level ground.
2. Elevate front of vehicle securely and safely until tires leave ground.
3. Safely and securely support front frame of vehicle on adjustable jack stands
4. Remove front wheels/tires
5. Remove front swaybar links from vehicle
6. Remove brakeline mounting bolt at frame on both driver and passenger side. Do not disassemble brakeline itself.
7. Remove front shocks
8. Remove front springs
9. Working on the driver side first, remove factory lower front control arm
10. Install Supplied EVO Front lower control arm on driver side with zerk fitting on both ends facing upwards. The arms should bend towards the inside of the vehicle with the clamping tubes at the axle end facing upwards. Starting length of control arms from center of hole to center of hole at the joints should be 22 7/8". This is a recommended starting length and will change after a professional alignment has been performed. Adjusting control arm length should be made using the OnVehicle adjuster starting with the joint and adjuster threaded completely in.
11. Torque both bolts to factory specifications
12. Repeat previous three steps on passenger side.



13. On both driver and passenger side, drill and 5/16" hole in the center of the spring mount on axle.
14. Using supplied self threading bolt, place the bumpstop extensions over the drilled hole on the axle and thread through the center the self threading bolt on both driver and passenger sides
15. Install front coil springs on both driver and passenger sides, smaller pigtail end of spring should be at the frame side (top) with the factory coil spring rubber isolator retained at the top. Make sure lower mount is placed properly into the coil retaining location on the axle
16. Install front shocks top end first (studded end) with one rubber part on the top and one rubber part on the underside of the frame mount.
17. Slowly and carefully raise the axle until the driver side shock mount is line up with the factory axle hole. Install bolt and torque to factory specifications
18. Repeat previous step on passenger side



19. Installed supplied brakelines. Cut the thin support tie holding your brake line and ABS line together, separate the main plastic coupling holding your brake line and ABS lines together, Using an 11mm wrench, separate the hard line from the bracket/hose, using a 10mm socket, remove the bolt securing the bracket/hose to the frame rail and set aside the bolt for later use, Use a 10mm socket to secure your new stainless steel brake line mounting bracket to the frame rails using the factory bolt, using a 15mm socket, remove the banjo bolt securing your brake line to it and set it aside, Slip your new stainless steel brake line up through the new mounting bracket and then fasten the hard line to it using a 12mm and 17mm wrench, slip one of the new copper crush washers on to the factory banjo bolt, Insert the factory banjo bolt with copper crush washer on through the new stainless steel brake line and then slip on another copper crush washer, Using a 15mm socket, secure your new stainless steel break line to the break caliper, tighten the banjo bolt to 276 in. lbs. of torque (hard line elbow extends out and back). Secure your new stainless steel brake line to the mounting bracket using the retaining clip, attach your new stainless steel brake line and ABS wiring together using the factory main plastic coupler, zip-tie your new stainless steel brake line and ABS together as they were before, check the fluid level in your master cylinder.

20. Install new wheels
21. Torque lug nuts to factory specifications
22. Turn wheels full left and full right making sure all wires, brakelines and hoses are free from contact on any component.
23. Carefully lower front of vehicle onto ground
24. With vehicle on level ground.
25. Elevate rear of vehicle securely and safely until tires leave ground.
26. Safely and securely support rear frame of vehicle on adjustable jack stands
27. Remove rear wheels/tires
28. **Remove rear swaybar links from vehicle, these will be installed on the front later on.**
29. Remove brakeline mounting bolt at frame on both driver and passenger side.
30. Remove rear shocks
31. Remove rear springs
32. Remove rear parking brake cables from mounting bracket on floorboard of vehicle.
33. Remove rear trackbar bolt at axle, leave trackbar bolt at frame installed

34. Cut factory rear trackbar as shown. Only remove the rear most part of the bracket.



35. Sand all cuts smooth with flat mounting plate.



36. Install rear trackbar bracket as shown with supplied 9/16 bolt and ubolts.

37. Weld on rear trackbar bracket to axle where ever possible, see photo



38. Reinstall trackbar into new higher location with factory bolt. (torque to factory specifications once vehicle is on ground and at ride height.)

39. Install shocks in upper mounts with supplied bracketry and hardware



40. Install springs into lower axle mount, smaller end of spring should be mounted on the axle side. Larger end of spring goes up while retaining the factory rubber coil spring isolator

41. Slowly and carefully raise axle until lower shock mounts line up with axle mounting bolt holes. Make sure upper coil springs and isolators are properly centered in coil spring perches on top and bottom

42. Install shocks bolts at axle





Install rear brakelines Using a 15mm socket remove the banjo bolt from caliper, Remove the banjo bolt from the brake hose, remove the copper washers and keep them aside you will need to reuse them. Using an 11mm wrench, separate the hard line from the bracket/hose, using a 10mm socket, remove the bolt securing the bracket/hose to the frame rail and set aside the bolt for later use. Install new copper crush washers on to the factory banjo bolt, Insert the factory banjo bolt with copper crush washer on through the new stainless steel brake line, then slip another copper crush washer on. Using a 15mm socket, secure your new stainless steel break line to the break caliper, tighten the banjo bolt to 276 in. lbs. of torque (hard line elbow extends out and back).

Use a 10mm socket to secure your new stainless steel brake line mounting brackets to the frame rails using the factory bolts, Slip your new stainless steel brake line up through the new mounting bracket, fasten the factory hard line to it using a 12mm and 17mm wrench, Secure your new stainless steel brake line to the mounting bracket using the retaining clip, Check the fluid level in your master cylinder. Bleed brakes following factory procedure.

43. Install Swaybar bushings into supplied swaybar links, use of a lubricant and a small hammer will assist in this process, install swaybar endlink tubes into swaybar bushings. Install supplied EVO Endlinks into swaybar and axle mounts on both driver and passenger side rear.



44. Install rear bumpstop extensions on axle with supplied 5/16" hardware
45. Install new wheels and carefully lower vehicle onto ground.
- 46. Install the factory rear swaybar endlinks on the front of the vehicles swaybar.**
47. Torque lug nuts to factory specifications
48. Torque all bolts to factory specifications
49. Retorque all hardware after 500 miles and every off road trip.

Size	Recommended Torque											
	Grade 2		Grade 5		Grade 8		18-8 S/S		Bronze		Brass	
	Coarse	Fine	Coarse	Fine	Coarse	Fine	Coarse	Fine	Coarse	Fine	Coarse	Fine
<b>#4*</b>	-	-	-	-	-	-	5.2	-	4.8	-	4.3	-
<b>#6*</b>	-	-	-	-	-	-	9.6	-	8.9	-	7.9	-
<b>#8*</b>	-	-	-	-	-	-	19.8	-	18.4	-	16.2	-
<b>#10*</b>	-	-	-	-	-	-	22.8	31.7	21.2	29.3	18.6	25.9
<b>1/4</b>	4	4.7	6.3	7.3	9	10	6.3	7.8	5.7	7.3	5.1	6.4
<b>5/16</b>	8	9	13	14	18	20	11	11.8	10.3	10.9	8.9	9.7
<b>3/8</b>	15	17	23	26	33	37	20	22	18	20	16	18
<b>7/16</b>	24	27	37	41	52	58	31	33	29	31	26	27
<b>1/2</b>	37	41	57	64	80	90	43	45	40	42	35	37
<b>9/16</b>	53	59	82	91	115	129	57	63	53	58	47	51
<b>5/8</b>	73	83	112	128	159	180	93	104	86	96	76	85
<b>3/4</b>	125	138	200	223	282	315	128	124	104	102	118	115
<b>7/8</b>	129	144	322	355	454	501	194	193	178	178	159	158
<b>1+</b>	188	210	483	541	682	764	287	289	265	240	235	212



## EVO-1069 EVO MFG JK Tire Carrier



	QTY	PART#	DESCRIPTION
<input type="checkbox"/>	4	EVO-600030	CE-9114 JOHNNY JOINT 2 ½"
<input type="checkbox"/>	1	EVO-11077	Tire Carrier Mount/ Fuel Door
<input type="checkbox"/>	3	EVO-11076	Tire Carrier Mount
<input type="checkbox"/>	4	EVO-900251	1 ¼ -12 HEX JAM NUT STEEL/ZINC
<input type="checkbox"/>	1	EVO-10065	WHEEL MOUNT
<input type="checkbox"/>	1	EVO-770021	TIRE CARRIER HARDWARE PACK
<input type="checkbox"/>	1	EVO-10064-11	T-HANDLE BUNG
<input type="checkbox"/>	3	EVO-9000039	HHCS ½ -20 X1.5 GR8 ZINC
<input type="checkbox"/>	1	EVO-10064	REAR TIRE CARRIER

**NOTES: THIS IS NOT AN EASY INSTALL. Requires EVO MFG Rear Rockskins or EVO Armor to complete install. This kit requires drilling into the body of your vehicle. Due to vehicle variances from the factory, the carrier will require finesse and possibly adjustments to its shape for fitment. They will not just directly line up with the complex contours of the vehicle, you will need to adjust the joint length on all four corners to make fitment. If you do not have this ability, or are intimidated with this install process, or are not willing to accept the responsibility of YOU making these mount to your vehicle, DO NOT proceed. If it was easy, everyone would be doing it. Install/test fit Armor/Carrier before painting/powder coating. Paint/Powder Coat all surfaces before final installation. Use of Anti Seize on all threads is recommended during final assembly. Maximum distance from wheel mounting surface to outside bulge of tire is 9.5"**

1. With EVO RockSkins or EVO Armor installed. Fully thread the 4 jam nuts onto the 4 Johnny Joints.
2. Fully thread the 4 Johnny Joints into the four ends of the tire carrier
3. Using the supplied EVO Brackets and hardware, install each mounting bracket to the tire carrier Johnny Joints. There are 2 different mounting brackets (3 square ended ones, and 1 with a radiused end). The radiused mounting bracket must be mounted on the driver upper side of the tire carrier, around gas cap. The outside of all mounting plates are shown in photo, this is the side of the mounting plates that has the gusset plate with the circular hole.
4. Hold the carrier up to the armor. The hole stated as the height alignment hole in the attached picture is an existing hole in the EVO Armor. This hole will give you an alignment location on the driver side. Since the armor can be mounted differently on the passenger side, this is the only alignment location. Install is the bolt. NOTE: pinch seam may need to be bent back to clearance for gas filler.
5. With the tire carrier held up on passenger side and alignment bolt installed. Hold carrier close to body. This is where you will need to adjust the joints of the carrier in and or out in various configurations in order

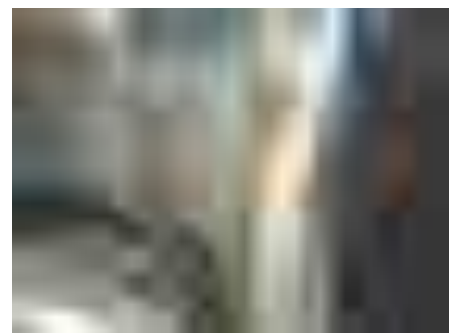

to get all 4 mounting plates to align with the installed Armor. Every armor install is different and therefore you will need to go back and forth with the joint adjustments until you get an acceptable fit where all 4 bracket line up to the armor contours.



6. Once all 4 brackets line up the armor hole carrier level to body with alignment bolt installed and mark all 15 holes to be drilled on the mounting plates.
7. With a 5/16" drill bit drill through the armor and outer section of the body on one mounting bracket at a time.
8. Install this bracket loosely using the supplied hardware. You can access the through bolts by the underside of body just behind the taillight. There may be a foam block covering this access, move out of the way.
9. Continue to drill the other 3 mounting bracket holes and loosely install all brackets.
10. Install tire carrier to brackets using the two 1/2" bolts on the passenger side and the pins on the driver side.
11. Tighten all mounting brackets to body.
12. Test pins ability to pull in and out. Some adjustment of either the pin holes or joint threading may be needed to allow the pins to move freely in and out at this stage. Do so as needed.
13. To install the tire, remove T-Handle on center of tire carrier and wheel mounting plate.



14. Install wheel mounting plate to spare tire/wheel with the plate on the back side wheel, just as would be installed on the vehicle. Stud on plate should be sticking out towards front side wheel.

15. Install lug nuts onto the 3 studs.

16. Lift wheel and slide protruding tube on wheel mounting plate onto the center protruding threaded tube on tire carrier.



17. Slide T handle through the center hole of the wheel mounting plate and tread into tire carrier. Tighten. You do not need to over tighten this connection. Make sure tire is fully seated against tire carrier and T handle is snug and secure.





EVO-1070

## EVO MFG Rear Rockskin Corners



**NOTES, Please Read: Aftermarket taillights are required and sold separately. This kit requires drilling into the body of your vehicle. Due to vehicle variances from the factory, the RockSkins will require finesse and possibly adjustments to its shape for fitment. You WILL need to clamp these to the body, thereby pulling the Rear RockSkins to your vehicle. They will not just directly line up with the complex contours of the vehicle. If you do not have this ability, or are intimidated with this install process, or are not willing to accept the responsibility of YOU making these mount to your vehicle, DO NOT proceed. If it was easy, everyone would be doing it. Install/test fit Armor before painting/powder coating. Paint/Powder Coat all surfaces before final installation**

1. Remove gas cap

2. Pull to remove circular gas filler cover. The neck of the filler tube is held in by the rubber ring around the neck and the cover plate. Separate the neck from the plate
3. Remove factory taillights and license plate mount
4. On driver side hold EVO Driver Side RockSkin (part with large circle for gas fill) to driver side rear fender.



5. Use a large C-clamp through the rear taillight hole in body and clamp RockSkin to body. The use of a good ratchet strap attached to the door striker and tailgate striker will aid in pulling the rockskin to the body. ( See Photo )

6. Continue clamping Rockskin until you have a satisfactory edge between the fenders and door line.

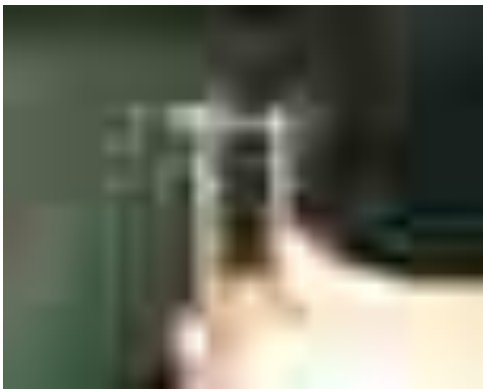

7. Mark all holes to be drilled.
8. Drill all holes with 3/8" drill bit. (step drills work really well, you want the hole to be just undersized so the nutserts will insert into the drilled hole with a small amount of resistance) light tap of the hammer.



9. Install nutserts into drilled holes. Fully thread the long 1/4" bolt with nut into the nutsert as seen in photo. With wrenches hold the bolt stationary and turn the nut 2 - 3 turns making sure that the nutsert does **NOT** turn. (There are tools specifically designed for installing these nutserts. Please



call for more information if you would like information on where to purchase this tool, they make install much easier)



10. With all nutserts installed, install RockSkin to fender with supplied ¼-20 Stainless flat head screws
11. Repeat last seven steps on passenger side (no gas filler)
12. Using the RockSkin as a template, cut the rear body in the circle of the RockSkin. Use a body saw, plasma cutter (be very careful of wiring and flammable materials) etc.



**Nutsert tool / Thread insert tool can be found online at such places as Amazon, Harbor Freight, and many other tool supply companies web sites.**



**UPON OPENING YOUR PACKAGES,  
INSPECT THE CONTENTS IMMEDIATELY.**

If you have any missing or damaged parts, or are missing the hardware pack, contact EVO Manufacturing immediately at (714) 879-8913. EVO Manufacturing is not responsible for claims of missing or damaged parts if notified more than 15 days after delivery, proof of purchase is required.

**DO NOT POWDERCOAT, PAINT, ETC ANY  
OF YOUR PARTS BEFORE PERFORMING A  
TEST FITMENT FIRST.**

Any damaged or defective parts must be identified before powdercoating or painting the parts. EVO Manufacturing is not responsible for any powdercoating or painting related costs of parts that were not properly test fitted prior to powdercoat or paint.

EVO Manufacturing

1835 W Commonwealth Ave Fullerton CA 92833 (714) 879.8913



## EVO1071 – JK Drag Link Flip Kit / EVO-1089 JK Draglink Flip Kit ProRock44



**EVO-1071**



**EVO-1089**

**This kit requires the use of a 13/16 drill which is not supplied. Welding of all brackets at axle is always recommended. Use of thread lock (such as Loctite is recommended on all bolts). 3" or larger front bumpstop extensions are required to be installed on vehicle and are not supplied.**

QTY	PART#	DESCRIPTION
<input type="checkbox"/>	<b><u>EVO-1071</u></b>	
<input type="checkbox"/>	1 EVO-11042B	REARWARD BRACKET JK FRONT TRACKBAR BRACKET
<input type="checkbox"/>	1 EVO-11043B	JK FRONT TRACKBAR BRACKET, BLACK
<input type="checkbox"/>	1 EVO-11044B	DRIVER SIDE SWAYBAR LINK BRACKET, BLACK
<input type="checkbox"/>	1 EVO-600089	DRAG LINK RHD JK
<input type="checkbox"/>	1 EVO-20022CZ	JK STEERING FLIP ADAPTOR
<input type="checkbox"/>	1 EVO-770027	EVO FRONT JK TRACKBAR BRACKET HARDWARE PACK
<input type="checkbox"/>	<b><u>EVO-1089</u></b>	
<input type="checkbox"/>	1 EVO-12002B	REARWARD BRACKET
<input type="checkbox"/>	1 EVO-12001B	JK FRONT TRACKBAR BRACKET
<input type="checkbox"/>	1 EVO-600089	DRAG LINK RHD JK
<input type="checkbox"/>	1 EVO-20022CZ	JK STEERING FLIP ADAPTOR
<input type="checkbox"/>	1 EVO-770027	TRACKBAR BRACKET HARDWARE

1. Careful elevate front of vehicle by raising at axle and carefully place jack stands under axle.
2. Remove both passenger and driver side tires.
3. Remove bolt at trackbar on passenger side at axle
4. Remove swaybar links from axle mounts.

5. Place the smaller supplied bracket into the axle trackbar mount
6. Using the supplied 9/16 bolt, washer and nut and smaller length 5/16 bolt washer and nuts, loosely bolt into place. Do not fully tighten.

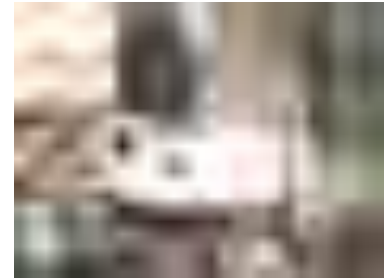

7. Place the larger supplied trackbar bracket onto the axle mount on the outside.
8. Using the supplied 9/16 bolt, washer and nut and smaller length 5/16 bolts washer and nuts, loosely bolt into place. Do not fully tighten.

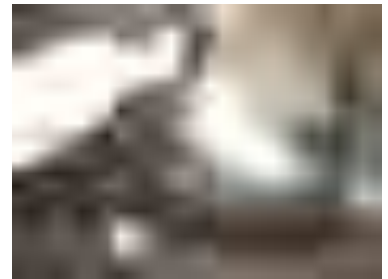

9. Insert the shorter 1/2" bolt with washers and nut for the side bolting the two pieces together.

10. Insert the u-bolt around the axle tube through the mount on the new supplied brackets. Use the supplied 3/8" Locknuts. Make sure to not over tighten.

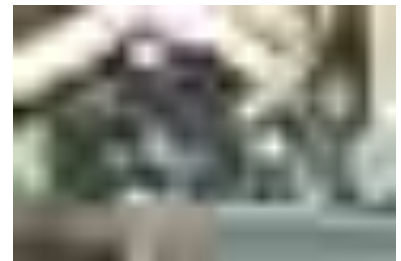

11. Insert the longer 1/2" bolt with washers and nut through the factory swaybar tab first, then through the supplied trackbar brackets.

12. Tighten all supplied bolts to torque specs at end of these instructions.

13. Remove nut at draglink/steering knuckle connection. Remove Draglink from steering knuckle. This may require you to hit steering knuckle where draglink mounts with small sledge hammer.

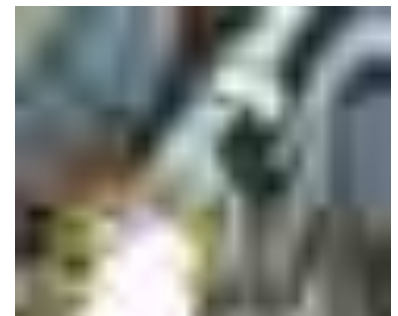

14. Remove draglink from factory coupler up towards the pitman arm. You do not want to remove the joint at the pitman arm, just the bar from the coupler. Leave all other components installed as from the factory.

15. With a 13/16" drill bit, drill straight down through factory knuckle where draglink stud was previously mounted. Be as careful as possible to drill straight through knuckle.



16. Using supplied crush sleeve, insert from top down into newly drilled hole in knuckle

17. Using the supplied draglink, thread into coupler at pitman arm end.

18. Insert the new draglink from the top down through the newly installed crush sleeve at the steering knuckle.

19. Using the factory nut removed from the factory draglink, install on to newly installed draglink. Use of a thread locking compound is recommended.



20. On driver side, hold up the swaybar extension tab to factory swaybar tab on the inside of factory swaybar tab. ( **Not applicable on EVO-1089 ProRock44 Draglink Flip Kit** )

21. With bolt holes at the swaybar tab lined up. Mark the hole that needs to be drilled into the coil pocket.

22. With a 5/16" drill bit, drill marked hole into coil pocket. This may require the removal of your brake rotor on the driver side depending on your drilling equipment. If removed, follow factory specifications when removing and reinstalling.



23. With the supplied longer 1/2" bolt, washers and nut, bolt supplied bracket on the inside of the factory bracket.

24. Using the supplied longer 5/16" bolt, washers and nut bolt the supplied bracket to the coil spring mount. This will require the use of the supplied thick spacer tube between the supplied bracket and the coil mount.

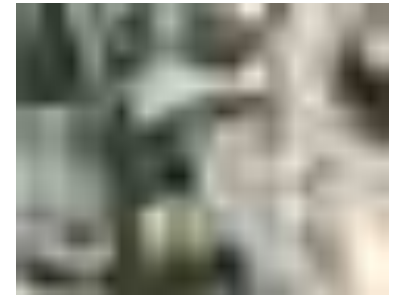

25. Reinstall the trackbar to its new higher location with factory hardware

26. Reinstall swaybar endlinks at their new higher location with factory hardware.

27. Torque all supplied bolts to torque specs and the end of these instructions.

28. Torque all factory bolts to factory specifications.

29. Reinstall wheels and torque to factory specifications.

30. Carefully lower vehicle back to ground.

31. Retorque all bolts after first 500 miles and every off road use.

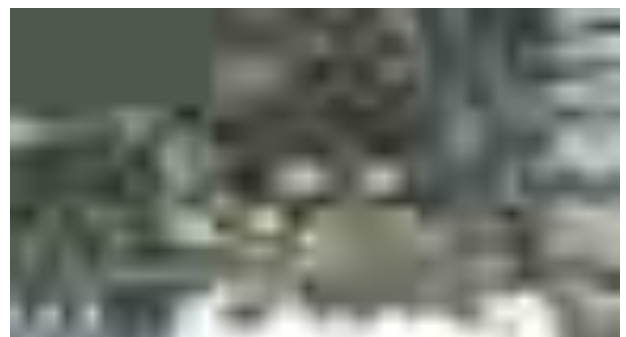

Size	Recommended Torque for Supplied Hardware											
	Grade 2		Grade 5		Grade 8		18-8 S/S		Bronze		Brass	
	Coarse	Fine	Coarse	Fine	Coarse	Fine	Coarse	Fine	Coarse	Fine	Coarse	Fine
<b>#4*</b>	-	-	-	-	-	-	5.2	-	4.8	-	4.3	-
<b>#6*</b>	-	-	-	-	-	-	9.6	-	8.9	-	7.9	-
<b>#8*</b>	-	-	-	-	-	-	19.8	-	18.4	-	16.2	-
<b>#10*</b>	-	-	-	-	-	-	22.8	31.7	21.2	29.3	18.6	25.9
<b>1/4</b>	4	4.7	6.3	7.3	9	10	6.3	7.8	5.7	7.3	5.1	6.4
<b>5/16</b>	8	9	13	14	18	20	11	11.8	10.3	10.9	8.9	9.7
<b>3/8</b>	15	17	23	26	33	37	20	22	18	20	16	18
<b>7/16</b>	24	27	37	41	52	58	31	33	29	31	26	27
<b>1/2</b>	37	41	57	64	80	90	43	45	40	42	35	37
<b>9/16</b>	53	59	82	91	115	129	57	63	53	58	47	51
<b>5/8</b>	73	83	112	128	159	180	93	104	86	96	76	85
<b>3/4</b>	125	138	200	223	282	315	128	124	104	102	118	115
<b>7/8</b>	129	144	322	355	454	501	194	193	178	178	159	158
<b>1†</b>	188	210	483	541	682	764	287	289	265	240	235	212



## **EVO-1072B**

### **RCC Rear Roll Center Correction Trackbar Bracket, JK**



**NOTES: Cutting and grinding is required to complete the installation of the rear roll center correction trackbar bracket. Welding on rear trackbar bracket is recommended after installation.**

	<b>QTY</b>	<b>PART#</b>	<b>DESCRIPTION</b>
<input type="checkbox"/>	1	EVO-760005	BOX 8x8x8
<input type="checkbox"/>	1	EVO-10080B	Rear Trackbar Bracket, JK, Black
<input type="checkbox"/>	1	EVO-7700021	Rear Trackbar Bracket Hardware Pack

1. Park vehicle on level ground.
2. Remove rear trackbar bolt at axle, leave trackbar bolt at frame installed

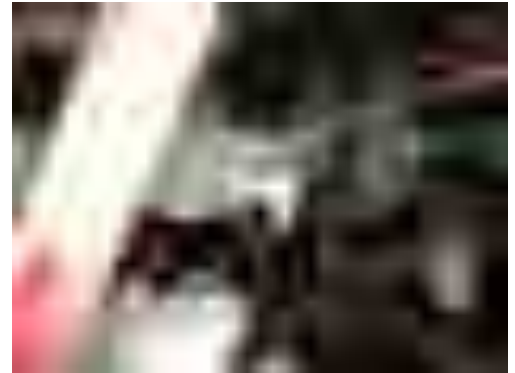

3. Cut factory rear trackbar bracket as shown. Only remove the rear most part of the bracket.



4. Sand all cuts smooth with flat mounting plate.

5. Install rear trackbar bracket as shown with supplied 9/16 bolt and U-bolts (make sure to use the locking nuts on the U-bolts).



6. Reinstall trackbar into new higher location with factory bolt. (torque to factory specifications once vehicle is on ground and at ride height.)
7. Torque lug nuts to factory specifications
8. Torque all bolts to factory specifications
9. Retorque all hardware after 500 miles and every off road trip.







EVO Manufacturing

Jeep Wrangler JK/JL and JT Gladiator

JK/JL/JT Gladiator Quarter Pounder D Rings

EVO- 1073





Before starting installation procedure please read <http://evomfg.com>Returns-Warranties-Shipping>

---

**CAREFULLY READ AND FOLLOW ALL INSTRUCTIONS IN THIS MANUAL AND KEEP FOR FUTURE REFERENCE. IF YOU HAVE ANY QUESTIONS ABOUT THE PRODUCT CALL EVO MANUFACTURING. FAILURE TO FOLLOW GUIDELINES COULD RESULT IN MALFUNCTION OF PARTS OR INJURY. PLEASE HAVE A TRAINED PROFESSIONAL ASSIST WITH OR INSTALL ALL PRODUCTS. INSTALLING EVO MFG PRODUCTS OR KITS DEMANDS SPECIFIC KNOWLEDGE, TOOLS AND EXPERIENCE. GENERAL KNOWLEDGE OF HOW TO USE LATER SPECIFIED TOOLS AND/OR LIMITED EXPERIENCE WITH EVO MFG PRODUCTS MAY NOT BE ENOUGH TO PROPERLY COMPLETE THESE TASKS. SOME OF EVO MFG PRODUCTS MAY REQUIRE TWO OR MORE PEOPLE TO INSTALL SAFELY AND CORRECTLY. DO NOT ATTEMPT ALONE, ALWAYS ENLIST THE HELP OF TRAINED PROFESSIONAL WHEN NEEDED.**

**Notes: Set Up Before installation**

**This is a general instruction for this component kit.**

**Directions/pictures may vary for each specific install, use for reference only.**

**Keep all mounting bolts loose (installed but not torqued) we will torque later at the end of complete installation**

**READ BEFORE INSTALL:**

It is generally a good idea to apply Loctite to all threaded bolts.

ALWAYS wear safety glasses and other approved safety gear when working on a vehicle.

All supplied bolts torqued according to chart at end of instruction.

It is recommended all installation be performed by a trained professional. Some modification may have to be done.

Paint all unfinished surfaces after install is complete.



Parts included: Table below shows EVO MFG D Rings for Quarter Pounder bumper.

Description	#	Part #	Quantity
Quarter Pounder D-Ring Mounts	1	EVO-1073	2





**Recommended Tools:**

- Standard sockets
  - Wrench set
  - drill
- 



Safety Steps for installation

- For installing EVO MFG products always use wheel chokes to block rear tires from rolling.
  - Always make sure you have everything necessary ready before install.
  - If you have to, carefully lift front of vehicle by front frame rails extending suspension until tires leave the ground, place frame on approved jack stands for vehicle. Verify all lines/wires are not over extended.
  - Remove tires if needed for easier install.
  - Make sure to wear safety equipment (eye protection, hand protection, foot protection etc.) at all times during installation.
  - Make sure all safety precautions have been taken.
  - Always check and replace any part of vehicle that is worn or broken before starting install.
  - Do not mix anything EVO with weaker alternatives.
  - It is generally a good idea to apply liquid threadlock to all bolts.
  - Tighten included hardware to torque specifications in bottom table unless it is otherwise specified, factory bolts should be torqued to factory Jeep specifications.
- 





## FRONT INSTALL

After putting vehicle safely into park, chalking tires and removing key.

1. Unbolt the 8 bolts on the inside of the bumper, retain for reuse.

Support bumper with stand, it may shift after bolts are removed.

---

**Note:** May need to drill one of the bumper bolt holes, drill large enough to insert supplied bolts. Approximately ½"

---





2. Place EVO MFG D-Rings onto the bumper and line up the mounting holes. Install supplied bolts/nuts.
- 



---

After Install:

- Tighten all bolts securing purchased parts to specified locations.
- After completing installation using provided instructions, go through all steps again to make sure nothing was missed, not tightened or improperly assembled.
- Some components may need to be purchased separately.
- Check turn signals, headlights, fog lights (if applicable), taillights, blinkers and windshield wipers.
- Adjust mirrors, speedometer and headlights if needed.
- Make sure all gauges are fully operational.
- Drive the vehicle slowly for a couple minutes, looking and listening for abnormal noises while driving. After modification of a vehicle there will be differences in driving experiences and capabilities, be mindful of that.
- Inspect and Retorque all Bolts after 500 miles of completed installation and regularly thereafter.
- Some modification may be required.



Recommended Torque:

Size	Grade 2		Grade 5		Grade 8		18-8 S/S	
	Coarse	Fine	Coarse	Fine	Coarse	Fine	Coarse	Fine
<b>#4*</b>	-	-	-	-	-	-	5.2	-
<b>#6*</b>	-	-	-	-	-	-	9.6	-
<b>#8*</b>	-	-	-	-	-	-	19.8	-
<b>#10*</b>	-	-	-	-	-	-	22.8	31.7
<b>1/4</b>	4	4.7	6.3	7.3	9	10	6.3	7.8
<b>5/16</b>	8	9	13	14	18	20	11	11.8
<b>3/8</b>	15	17	23	26	33	37	20	22
<b>7/16</b>	24	27	37	41	52	58	31	33
<b>1/2</b>	37	41	57	64	80	90	43	45
<b>9/16</b>	53	59	82	91	115	129	57	63
<b>5/8</b>	73	83	112	128	159	180	93	104
<b>3/4</b>	125	138	200	223	282	315	128	124
<b>7/8</b>	129	144	322	355	454	501	194	193
<b>1+</b>	188	210	483	541	682	764	287	289



## EVO-1077

### EVO 3" Front Bumpstop Spacer Kit



	<b>QTY</b>	<b>PART#</b>	<b>DESCRIPTION</b>
<input type="checkbox"/>	2	EVO-20005	Front Bumpstop Spacer 3"
<input type="checkbox"/>	2	EVO-900333	Thread-Cutting Screw for Metal&Plastic

1. Drill 5/16" hole in center of spring perch.
2. Using socket with extension, enter bolt into bump stop.
3. Place over hole drilled in spring perch.
4. Tighten bolt applying downward pressure keeping bolt as straight as possible to allow self tapping screw to thread.
5. Tighten snug, do not over tighten.





EVO Manufacturing

Jeep Wrangler JL/JT Gladiator

Front and Rear Bump Stop Extension

EVO-1077-25, 1077, 1066-25, 1066-3, 1066-4, 3080B-25, 3080B-3, 3080B-4





Before starting installation procedure please read <http://evomfg.com>Returns-Warranties-Shipping>

---

**CAREFULLY READ AND FOLLOW ALL INSTRUCTIONS IN THIS MANUAL AND KEEP FOR FUTURE REFERENCE. IF YOU HAVE ANY QUESTIONS ABOUT THE PRODUCT CALL EVO MANUFACTURING. FAILURE TO FOLLOW GUIDELINES COULD RESULT IN MALFUNCTION OF PARTS OR INJURY. PLEASE HAVE A TRAINED PROFESSIONAL ASSIST WITH OR INSTALL ALL PRODUCTS. INSTALLING EVO MFG PRODUCTS OR KITS DEMANDS SPECIFIC KNOWLEDGE, TOOLS AND EXPERIENCE. GENERAL KNOWLEDGE OF HOW TO USE LATER SPECIFIED TOOLS AND/OR LIMITED EXPERIENCE WITH EVO MFG PRODUCTS MAY NOT BE ENOUGH TO PROPERLY COMPLETE THESE TASKS. SOME OF EVO MFG PRODUCTS MAY REQUIRE TWO OR MORE PEOPLE TO INSTALL SAFELY AND CORRECTLY. DO NOT ATTEMPT ALONE, ALWAYS ENLIST THE HELP OF TRAINED PROFESSIONAL WHEN NEEDED.**

**Notes: Set Up Before installation**

**This is a general instruction for this component kit.**

**Directions/pictures may vary for each specific install, use for reference only.**

**Keep all mounting bolts loose (installed but not torqued) we will torque later at the end of complete installation**

**READ BEFORE INSTALL:**

It is generally a good idea to apply Loctite to all threaded bolts.

ALWAYS wear safety glasses and other approved safety gear when working on a vehicle.

All supplied bolts torqued according to chart at end of instruction.

It is recommended all installation be performed by a trained professional. Some modification may have to be done.

Paint all unfinished surfaces after install is complete.



Parts included: Table below shows JL/JT Front and Rear Bumpstop.

Description	#	Part #	Quantity
JL/JT Front 2.5" Bumpstops	1	EVO-1077-25	2
JL/JT 3" Front Bumpstops	2	EVO-1077	2
JL Rear 2.5" Bumpstop	3	EVO-1066-25	2
JL Rear 3" Bumpstop	4	EVO-1066-3	2
JL Rear 4" Bumpstop	5	EVO-1066-4	2
JT Rear 2.5" Bumpstop	6	EVO-3080B-25	2
JT Rear 3" Bumpstop	7	EVO-3080B-3	2
JT Rear 4" Bumpstop	8	EVO-3080B-4	2





**Recommended Tools:**

- Wrench/Socket set



**Safety Steps for installation**

- For installing EVO MFG products always use wheel chokes to block rear tires from rolling.
- Always make sure you have everything necessary ready before install.
- If you have to, carefully lift front of vehicle by front frame rails extending suspension until tires leave the ground, place frame on approved jack stands for vehicle. Verify all lines/wires are not over extended.
- Remove tires if needed for easier install.
- Make sure to wear safety equipment (eye protection, hand protection, foot protection etc.) at all times during installation.
- Make sure all safety precautions have been taken.
- Always check and replace any part of vehicle that is worn or broken before starting install.
- Do not mix anything EVO with weaker alternatives.
- It is generally a good idea to apply liquid threadlock to all bolts.
- Tighten included hardware to torque specifications in bottom table unless it is otherwise specified, factory bolts should be torqued to factory Jeep specifications.





## **FRONT INSTALL**

1. Insert supplied 3/8 x 2" bolt into front bumpstop extension. Place bumpstop with bolt inside (bore side up) EVO MFG Front Coil spring.

**Axle may need to be lowered to install.**

2. With spring in place and bumpstop extension sitting on axle pad and bolt inserted into bumpstop extension. Install supplied 3/8" nut from under spring pad to bolt inserted inside bump stop extension and tighten
- 





## REAR INSTALL

3. Install rear bump stop extensions to axle pads on both passenger and driver side axle pads using supplied 5/16" x .75 bolts, washers and nuts.

Axle may need to be lowered to install.



### After Install:

- Tighten all bolts securing purchased parts to specified locations.
- After completing installation using provided instructions, go through all steps again to make sure nothing was missed, not tightened or improperly assembled.
- Some components may need to be purchased separately.
- Check turn signals, headlights, fog lights (if applicable), taillights, blinkers and windshield wipers.
- Adjust mirrors, speedometer and headlights if needed.
- Make sure all gauges are fully operational.
- Drive the vehicle slowly for a couple minutes, looking and listening for abnormal noises while driving. After modification of a vehicle there will be differences in driving experiences and capabilities, be mindful of that.
- Inspect and Retorque all Bolts after 500 miles of completed installation and regularly thereafter.
- Some modification may be required.



Recommended Torque:

Size	Grade 2		Grade 5		Grade 8		18-8 S/S	
	Coarse	Fine	Coarse	Fine	Coarse	Fine	Coarse	Fine
<b>#4*</b>	-	-	-	-	-	-	5.2	-
<b>#6*</b>	-	-	-	-	-	-	9.6	-
<b>#8*</b>	-	-	-	-	-	-	19.8	-
<b>#10*</b>	-	-	-	-	-	-	22.8	31.7
<b>1/4</b>	4	4.7	6.3	7.3	9	10	6.3	7.8
<b>5/16</b>	8	9	13	14	18	20	11	11.8
<b>3/8</b>	15	17	23	26	33	37	20	22
<b>7/16</b>	24	27	37	41	52	58	31	33
<b>1/2</b>	37	41	57	64	80	90	43	45
<b>9/16</b>	53	59	82	91	115	129	57	63
<b>5/8</b>	73	83	112	128	159	180	93	104
<b>3/4</b>	125	138	200	223	282	315	128	124
<b>7/8</b>	129	144	322	355	454	501	194	193
<b>1†</b>	188	210	483	541	682	764	287	289



EVO Manufacturing

Jeep Wrangler JK/JL and JT Gladiator

JK/JL/JT Gladiator Quarter Pounder Stinger

EVO- 1079







Before starting installation procedure please read <http://evomfg.com>Returns-Warranties-Shipping>

---

**CAREFULLY READ AND FOLLOW ALL INSTRUCTIONS IN THIS MANUAL AND KEEP FOR FUTURE REFERENCE. IF YOU HAVE ANY QUESTIONS ABOUT THE PRODUCT CALL EVO MANUFACTURING. FAILURE TO FOLLOW GUIDELINES COULD RESULT IN MALFUNCTION OF PARTS OR INJURY. PLEASE HAVE A TRAINED PROFESSIONAL ASSIST WITH OR INSTALL ALL PRODUCTS. INSTALLING EVO MFG PRODUCTS OR KITS DEMANDS SPECIFIC KNOWLEDGE, TOOLS AND EXPERIENCE. GENERAL KNOWLEDGE OF HOW TO USE LATER SPECIFIED TOOLS AND/OR LIMITED EXPERIENCE WITH EVO MFG PRODUCTS MAY NOT BE ENOUGH TO PROPERLY COMPLETE THESE TASKS. SOME OF EVO MFG PRODUCTS MAY REQUIRE TWO OR MORE PEOPLE TO INSTALL SAFELY AND CORRECTLY. DO NOT ATTEMPT ALONE, ALWAYS ENLIST THE HELP OF TRAINED PROFESSIONAL WHEN NEEDED.**

**Notes: Set Up Before installation**

**This is a general instruction for this component kit.**

**Directions/pictures may vary for each specific install, use for reference only.**

**Keep all mounting bolts loose (installed but not torqued) we will torque later at the end of complete installation**

**READ BEFORE INSTALL:**

It is generally a good idea to apply Loctite to all threaded bolts.

ALWAYS wear safety glasses and other approved safety gear when working on a vehicle.

All supplied bolts torqued according to chart at end of instruction.

It is recommended all installation be performed by a trained professional. Some modification may have to be done.

Paint all unfinished surfaces after install is complete.



Parts included: Table below shows EVO MFG Stinger for Quarter Pounder bumper.

Description	#	Part #	Quantity
Quarter Pounder Stinger	1	EVO-1079	1





#### **Recommended Tools:**

- Standard sockets
  - Wrench set
- 



#### **Safety Steps for installation**

- For installing EVO MFG products always use wheel chokes to block rear tires from rolling.
  - Always make sure you have everything necessary ready before install.
  - If you have to, carefully lift front of vehicle by front frame rails extending suspension until tires leave the ground, place frame on approved jack stands for vehicle. Verify all lines/wires are not over extended.
  - Remove tires if needed for easier install.
  - Make sure to wear safety equipment (eye protection, hand protection, foot protection etc.) at all times during installation.
  - Make sure all safety precautions have been taken.
  - Always check and replace any part of vehicle that is worn or broken before starting install.
  - Do not mix anything EVO with weaker alternatives.
  - It is generally a good idea to apply liquid threadlock to all bolts.
  - Tighten included hardware to torque specifications in bottom table unless it is otherwise specified, factory bolts should be torqued to factory Jeep specifications.
- 





## **FRONT INSTALL**

After putting vehicle safely into park, chalking tires and removing key.

1. Unbolt the 8 bolts on the inside of the bumper, retain for reuse.

**Note:** Support bumper with stand, it may shift after bolts are removed. May need to drill one of the bumper bolt holes, drill large enough to insert supplied bolts. Approximately ½"





2. Place EVO MFG Stinger onto the bumper and line up the mounting holes. Reinstall bolts/nuts.
- 



3. Using the upper holes as a reference, drill through the holes, into the top of the bumper.

Recommended to paint all bare surfaces to prevent rust.

---





4. Using supplied hardware attach Stinger to the top of the Bumper.
- 



---

After Install:

- Tighten all bolts securing purchased parts to specified locations.
- After completing installation using provided instructions, go through all steps again to make sure nothing was missed, not tightened or improperly assembled.
- Some components may need to be purchased separately.
- Check turn signals, headlights, fog lights (if applicable), taillights, blinkers and windshield wipers.
- Adjust mirrors, speedometer and headlights if needed.
- Make sure all gauges are fully operational.
- Drive the vehicle slowly for a couple minutes, looking and listening for abnormal noises while driving. After modification of a vehicle there will be differences in driving experiences and capabilities, be mindful of that.
- Inspect and Retorque all Bolts after 500 miles of completed installation and regularly thereafter.
- Some modification may be required.



Recommended Torque:

Size	Grade 2		Grade 5		Grade 8		18-8 S/S	
	Coarse	Fine	Coarse	Fine	Coarse	Fine	Coarse	Fine
<b>#4*</b>	-	-	-	-	-	-	5.2	-
<b>#6*</b>	-	-	-	-	-	-	9.6	-
<b>#8*</b>	-	-	-	-	-	-	19.8	-
<b>#10*</b>	-	-	-	-	-	-	22.8	31.7
<b>1/4</b>	4	4.7	6.3	7.3	9	10	6.3	7.8
<b>5/16</b>	8	9	13	14	18	20	11	11.8
<b>3/8</b>	15	17	23	26	33	37	20	22
<b>7/16</b>	24	27	37	41	52	58	31	33
<b>1/2</b>	37	41	57	64	80	90	43	45
<b>9/16</b>	53	59	82	91	115	129	57	63
<b>5/8</b>	73	83	112	128	159	180	93	104
<b>3/4</b>	125	138	200	223	282	315	128	124
<b>7/8</b>	129	144	322	355	454	501	194	193
<b>1†</b>	188	210	483	541	682	764	287	289



### **EVO-1083 Rear Bolt-On D-Ring Mounts**

Notes: Use at your own risk! Check your local laws as to whether this product and/or operating a vehicle without a rear bumper is legal. For off road use only.

	<b>QTY</b>	<b>PART#</b>	<b>DESCRIPTION</b>
<input type="checkbox"/>	2	EVO-11052B	REAR FRAME SHACKLEMOUNTS
<input type="checkbox"/>	1	EVO-11053B	OUTER FRAME MOUNT PASS
<input type="checkbox"/>	1	EVO-11054B	OUTER FRAME MOUNT DRIVER
<input type="checkbox"/>	1	EVO-770043	BOLT ON D-RING HARDWARE PACK
<input type="checkbox"/>	2	EVO-12031	CZ NUT TAB

**\*ALWAYS STAY CLEAR OF ALL TOW POINTS (EVO-1083 or similar) AND OTHER ITEMS WHEN PULLING/TOWING\***

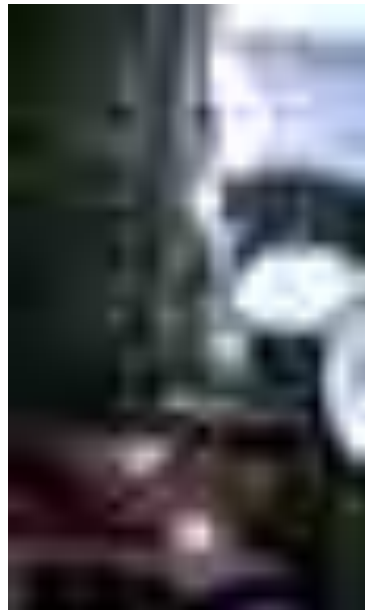
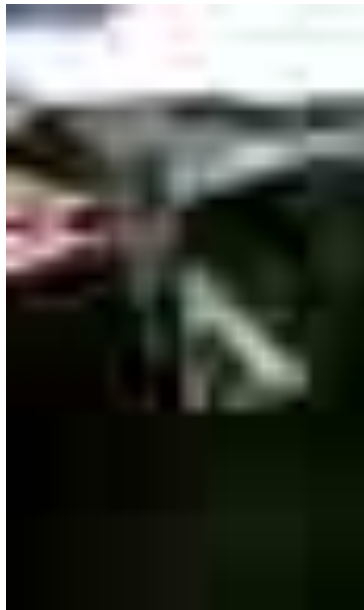



1. Remove the 2 bolts on each side of the rear frame attaching factory rear bumper to frame. Both passenger and driver sides. Retain bolts, they will be reused.
2. Remove the two bolts, one on driver and one on passenger side threaded into back of bumper just under rear door. These can be accessed from underneath the vehicle just on top of rear most crossmember on frame.
3. Remove bumper
4. Some JKs come with hooks and tow points on either the driver or passenger side rear frame rail. These will need to be removed.
5. With the rear frame rails now completely exposed, insert the EVO rear D-Ring mounts into the rectangle opening on the rear frame on the driver side. May need to be tapped into frame.
6. Supplied are two side mount plates (ones with "EVO" cut into them), one for the driver and one for the passenger side. Only difference is the logo will be opposite. With the driver side plate, logo legible, loosely install the two bolts through the EVO side mount plate that originally held on the bumper onto the side of the frame into their original holes.
7. Install the 9/16" bolts with a small washer on the head side through the side mount plate then the frame and EVO D-Ring mounts.
8. **\*\*The forward bolt uses the larger washer on the inside of the frame and then a nut\*\***
9. The rear bolt uses the smaller washer on the inside of the frame and the supplied nut plate. This nut plate will need to be fit into the gap on the crossmember on the rear of the vehicle to assess the bolt. This can be done by cutting/grinding a small amount of the metal until the nut can be fished in or with a few taps of a hammer to open the hole slightly.
10. Tighten factory bolts to 35 ft/lbs. Tighten 9/16 bolts to 120 ft/lbs
11. Repeat the previous 6 steps on passenger side.



Optional: For a flush mount with the frame, use a Sawzall or similar tool and cut rear frame ends flush with rear crossmember.



## EVO-1085 JK Doubled Long Arm Upgrade

## EVO-1084-35/37 JK Doubled LongArm Kit



**NOTES:** Cutting and grinding is required to complete the installation. Wheel spacers or aftermarket wheels with a smaller backspacing than factory (4.5" or smaller number are recommended) are required for a complete installation. Aftermarket CV drivelines are recommended. **Recommended: All Vehicles that spend time on salted roads. It is recommended that removal of both threaded collar and joint on all arms. Apply a small amount of Anti Seize on threads and reassemble.**

## Welding on all brackets is recommended.

### BOX #'s 1-2-3 INCLUDED IN FULL DD KIT EVO-1084-35/37 and EVO-1085

QTY	PART#	DESCRIPTION
☐	1	<b>EVO-760009</b> <b>BOX#1 40X9X9</b>
☐	2	EVO-11060B 31LA Tube Steel Front Lower JK
☐	2	EVO-11061B 27LA Tube Steel Rear Lower JK
☐	1	<b>EVO-760009</b> <b>BOX#2 40X9X9</b>
☐	1	EVO-11035B Rear Upper LA DRIVER BLK
☐	1	EVO-11036B Rear Upper LA PASS BLK
☐	1	EVO-11037B Front Upper LA DRIVER BLK
☐	1	EVO-11038B Front Upper LA PASS BLK
☐	1	<b>EVO-760009</b> <b>BOX#3 40X9X9</b>
☐	1	EVO-11008B DRIVER Rear LA Bracket
☐	1	EVO-11010B PASS Rear LA Bracket
☐	1	EVO-11049B DRIVER Front LA Control Arm Bracket
☐	1	EVO-11050B PASS Front LA Control Arm Bracket
☐	3	EVO-11005CZ JK Rear Upper Bolt Tab LA
☐	1	EVO-11006CZ Nut Tab JK Rear DRing, Clear Zinc
☐	1	EVO-770024 LA Upgrade HARDWARE Pack
☐	4	EVO-100563263 Misalignment Spacer
☐	2	EVO-900044 HHCS ½-20 x4.00 Gr* Zinc
☐	4	EVO-900216 SAE Washer ½ Thru Hardend Zinc
☐	2	EVO-900223 Stover Lock Nut ½-20 GrC Zinc
☐	2	EVO-900048 HHCS 9/16-18 1.50 Gr8 Zinc
☐	2	EVO-900217 SAE Washer 9/16 Thru Hardend Zinc
☐	8	EVO-900023 HHCS 3/8-24 x1.50 Gr8 Zinc
☐	8	EVO-900221 Stover Lock Nut 3/8-24 GrC Zinc
☐	4	EVO-900325 HHCS M12, 130MM, 1.75MM, Partial Thread 8.8 Zinc

### BOX #'s 4-5-6 INCLUDED IN FULL DOUBLED KIT EVO-1084-35/37 only

☐	1	<b>EVO-760009</b> <b>BOX#4 40X9X9</b>
☐	2	EVO-20005 3" Front Bumpstop Spacer
☐	2	EVO-900333 Thread Cutting Screw for Metal/ Plastic
☐	1	EVO-11042B Rearward Bracket JK Front Trackbar
☐	1	EVO-11043B JK Front Trackbar Bracket
☐	1	EVO-11044B Driverside Swaybar Link Bracket
☐	1	EVO-770027 Front Trackbar HARDWARE Pack
☐	1	EVO-600089 JK Draglink for Flip Kit
☐	1	EVO-20022CZ JK Steering Flip Adaptor, Clear Zinc
☐	1	EVO-10080B Rear Trackbar Bracket
☐	1	EVO-7700021 Rear RCC Trackbar Bracket HARDWARE Pack
☐	2	EVO-10081B /EVO-10082B Rear 3"/4" Bumpstop BLK
☐	4	EVO-900281 HHCS 5/16-24 x 0.75
☐	8	EVO-900213 SAE Washer 5/16 Thru Hardend Zinc
☐	4	EVO-900220 Stover Lock Nut 5/16-24 GrC Zinc
☐	2	EVO-600067 Brakeline Kit
☐	4	EVO-20032 Swaybar Bushing Tube
☐	4	EVO-600077 Bushing
☐	2	EVO-12029B Front Swaybar Link BLK
☐	4	EVO-900325 HHCS M12, 130MM Length, 1.75MM Pitch
☐	8	EVO-900326 Washer, M12, 24MM OD, 2.3MM-2.7MM
☐	4	EVO-900327 Metric Zinc-Plated Steel Nylon Insert Locknut
☐	1	EVO-770008 Shock Mounting HARDWARE Pack
☐	1	<b>EVO-760015</b> <b>BOX#5 24X12X6</b>
☐	2	EVO-600075/ EVO-600037 Front JK Coil Spring 3" / 4"
☐	1	<b>EVO-760015</b> <b>BOX#6 24X12X6</b>
☐	2	EVO-600076/ EVO-600038 Rear JK Coil Spring 3" / 4"

**NOTE: 2012+ model JK's use 4qty EVO-900325 (HHCS M12, 130mm, 1.75mm Partial Thread 8.8 Zinc ) Cross Member Bolts**

1. Park vehicle on level ground.
2. Elevate front of vehicle securely and safely until tires leave ground.
3. Safely and securely support front frame of vehicle on adjustable jack stands
4. Remove front wheels/tires
5. Remove front swaybar links from vehicle
6. Remove factory brakelines and bracket.
7. Remove bolts retaining brakeline brackets from frame
8. Remove front and rear shocks
9. Remove front and rear swaybar endlinks
10. Remove front and rear springs
11. Remove control arms
12. Cut Front factory control arm brackets as shown on lines in above photos. Removal of the inner portions are only required. Lower front factory need to be trimmed as shown leaving the outer factory portion of the bracket remaining on the vehicle.
13. Support transmission crossmember with adjustable jack stand. Remove two bolts on passenger side that hold in crossmember.
14. Install front passenger side brackets as shown. Mark upper front hole.
15. Remove bracket and drill  $\frac{1}{2}$ " through both sides of the frame.
16. Reinstall bracket and using factory bolts and supplied hardware.
17. Repeat steps on driver side.

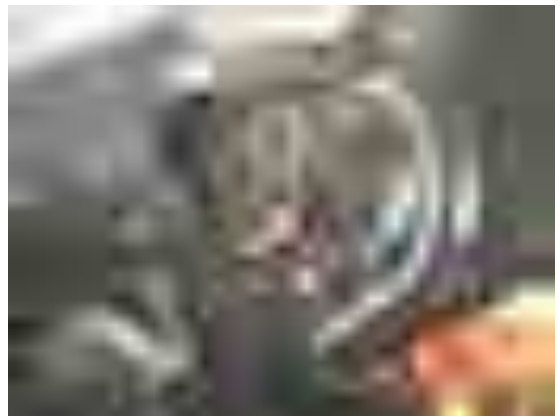

18. Install front control arms upper and lower using factory hardware on factory mounting locations and supplied hardware on EVO Brackets. Front lowers starting length 34.5" and upper starting length 26.375", roughly fully threaded. Front upper arms should bend away from frame. Insert 2 misalignments into each joint on front upper arm. Insert into



frame pocket with bolt going vertical (floor to roof).

**Rear:**

19. Carefully remove gas tank from vehicle. This can be heavy depending on fuel level. Be very careful as this contains highly flammable material.
20. Cut rear body mount as shown in photos. The rear most tab of the body mount needs to be trimmed all the way to the top. Grind all cuts smooth to frame.



21. Remove factory gas tank skid from gas tank.
22. CAREFULLY Cut square recess in outer part of factory gas tank skid plate in middle of support ribs. This allows for room for the lower control arm nut.

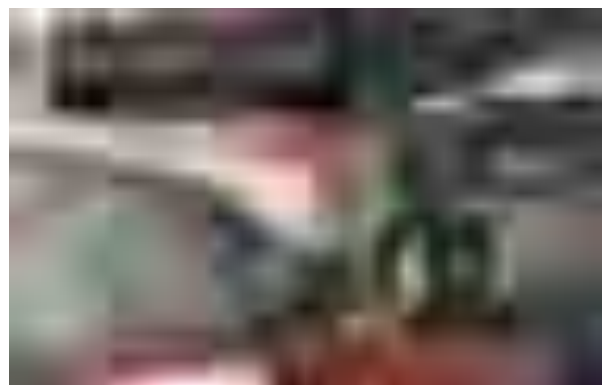

23. Cut factory rear control arm mounts as shown in photos. Grind all cuts smooth to frame.



24. Paint all exposed metal.

25. Remove two factory body mount bolts. The two outer small ones.
26. Install driver and pass side brackets on frame.
27. Tighten two body mount bolts to factory specifications.
28. Mark center of all holes and drill. **All 1/2" bolt drill through both sides of frame. All others drill through outside ONLY. For weld on installations, only drill the 9/16" (rear upper arm) holes through the outside of the frame only. Weld all edges of the brackets completely to frame.**
29. Install rear bracket on both driver and passenger side using supplied hardware.
30. Install upper and lower control arms into all remaining control arm mounts on axle and frame. Factory hardware at axle. Adjustable end at axle with crimp tubes up.



31. Use 2 (one each side) of the long flag nuts for the upper rear nuts, inserted through square hole on underside of frame just rear of control arm mount.
32. Adjusts rear lower control arm to 30.5" from center to center and uppers to 20.5" center to center. Roughly fully threaded in...

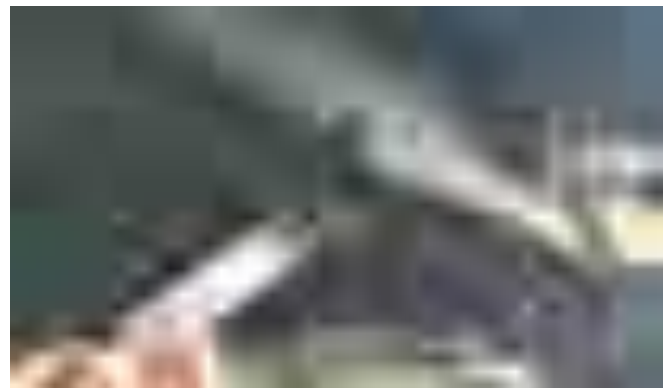

**Full DoubleD kit (Not upgrade):**

33. Remove bolt at trackbar on passenger side at axle
34. Place the smaller supplied bracket into the axle trackbar mount
35. Using the supplied 9/16 bolt, washer and nut and smaller length 5/16 bolt washer and nuts, loosely bolt into place. Do not fully tighten.
36. Place the larger supplied trackbar bracket onto the axle mount on the outside.
37. Using the supplied 9/16 bolt, washer and nut and smaller length 5/16 bolts washer and nuts, loosely bolt into place. Do not fully tighten.
38. Insert the shorter 1/2" bolt with washers and nut for the side bolting the two pieces together.
39. Insert the u-bolt around the axle tube through the mount on the new supplied brackets. Use the supplied 3/8" Locknuts. Make sure to not over tighten.
40. Insert the longer 1/2" bolt with washers and nut through the factory swaybar tab first, then through the supplied trackbar brackets.
41. Tighten all supplied bolts to torque specs at end of these instructions.
42. Remove nut at draglink/steering knuckle connection. Remove Draglink from steering knuckle. This may require you to hit steering knuckle where draglink mounts with small sledge hammer.
43. Remove draglink from factory coupler up towards the pitman arm. You do not want to remove the joint at the pitman arm, just the bar from the coupler. Leave all other components installed as from the factory.
44. With a 13/16" drill bit, drill straight down through factory knuckle where draglink stud was previously mounted. Be as careful as possible to drill straight through knuckle.
45. Using supplied crush sleeve, insert from top down into newly drilled hole in knuckle.
46. Using the supplied draglink, thread into coupler at pitman arm end.
47. Insert the new draglink from the top down through the newly installed crush sleeve at the steering knuckle
48. Using the factory nut removed from the factory draglink, install on to newly installed draglink. Use of a thread locking compound is

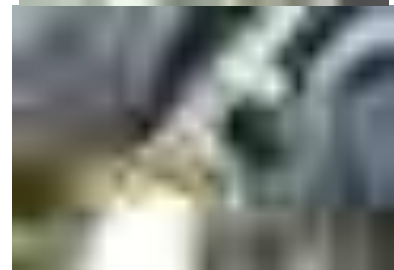
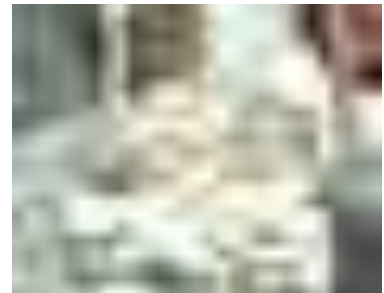
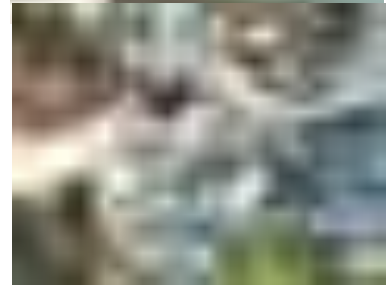
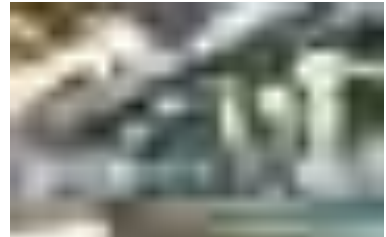
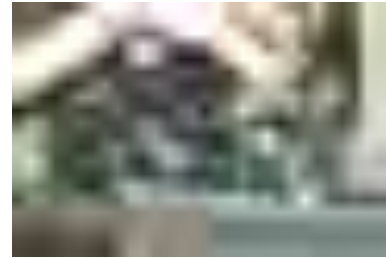



recommended.

49. On driver side, hold up the swaybar extension tab to factory swaybar tab on the inside of factory swaybar tab.
50. With bolt holes at the swaybar tab lined up. Mark the hole that needs to be drill into the coil pocket.
51. With a 5/16" drill bit, drill marked hole into coil pocket. This may require the removal of your brake rotor on the driver side depending on your drilling equipment. If removed, follow factory specifications when removing and reinstalling.
52. With the supplied longer 1/2" bolt, washers and nut, bolt supplied bracket on the inside of the factory bracket.
53. Using the supplied longer 5/16" bolt, washers and nut bolt the supplied bracket to the coil spring mount. This will require the use of the supplied thick spacer tube between the supplied bracket and the coil mount.
54. Reinstall the trackbar to its new higher location with factory hardware
55. On both driver and passenger side front, drill and 5/16" hole in the center of the spring mount on axle.
56. Using supplied self threading bolt, place the bumpstop extensions over the drilled hole on the axle and thread through the center the self threading bolt on both driver and passenger sides
57. Install front coil springs on both driver and passenger sides, smaller pigtail end of spring should be at the frame side (top) with the factory coil spring rubber isolator retained at the top. Make sure lower mount is placed properly into the coil retaining location on the axle
58. Install front shocks top end first (studded end) with one rubber part on the top and one rubber part on the underside of the frame mount.
59. Slowly and carefully raise the axle until the driver side shock mount is line up with the factory axle hole. Install bolt and torque to factory specifications
60. Repeat previous step on passenger side
61. Install supplied brakelines: Cut the thin support tie holding your brake line and ABS line together, separate the main plastic coupling holding your brake line and ABS lines together, Using an 11mm wrench, separate the hard line from the bracket/hose, using a 10mm socket, remove the bolt securing the bracket/hose to the frame rail and set aside the bolt for later use, Use a 10mm socket to secure your new stainless steel brake line mounting bracket to the frame rails using the factory bolt, using a 15mm socket, remove the banjo bolt securing your brake line to it and set it aside, Slip your new stainless steel brake line up through the new mounting bracket and then fasten the hard line to it using a 12mm and 17mm wrench, slip one of the new copper crush washers on to the factory banjo bolt, Insert the factory banjo bolt with copper crush washer on through the new stainless steel brake line and then slip on another copper crush washer, Using a 15mm socket, secure your new stainless steel break line to the break caliper, tighten the banjo bolt to 276 in. lbs. of torque (hard line elbow extends out and back). Secure your new stainless steel brake line to the mounting bracket using the retaining clip, attach your new stainless steel brake line and ABS wiring together using the factory main plastic coupler, zip-tie your new stainless steel brake line and ABS together as they were before, check the fluid level in your master cylinder.



62. Remove rear parking brake cables from mounting bracket on floorboard of vehicle.
63. Remove rear trackbar bolt at axle, leave trackbar bolt at frame installed

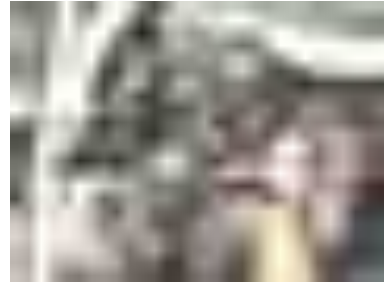
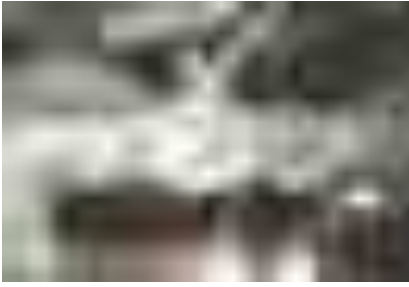
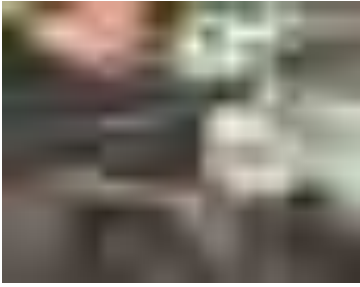

64. Cut factory rear trackbar as shown. Only remove the rear most part of the bracket.
65. Sand all cuts smooth with flat mounting plate.
66. Install rear trackbar bracket as shown with supplied 9/16 bolt and U-bolts (make sure to use the locking nuts on the U-bolts).
67. Weld on rear trackbar bracket to axle where ever possible
68. Reinstall trackbar into new higher location with factory bolt. (torque to factory specifications once vehicle is on ground and at ride height.)
69. Install shocks in upper mounts with supplied bracketry and hardware
70. Install springs into lower axle mount, smaller end of spring should be mounted on the axle side. Larger end of spring goes up while retaining the factory rubber coil spring isolator
71. Slowly and carefully raise axle until lower shock mounts line up with axle mounting bolt holes. Make sure upper coil springs and isolators are properly centered in coil spring perches on top and bottom
72. Install shocks bolts at axle
73. Install rear brakelines: Using a 15mm socket remove the banjo bolt from caliper, Remove the banjo bolt from the brake hose, remove the copper washers and keep them aside you will need to reuse them. Using an 11mm wrench, separate the hard line from the bracket/hose, using a 10mm socket, remove the bolt securing the bracket/hose to the frame rail and set aside the bolt for later use. Install new copper crush washers on to the factory banjo bolt, Insert the factory banjo bolt with copper crush washer on through the new stainless steel brake line, then slip another copper crush washer on. Using a 15mm socket, secure your new stainless steel break line to the break caliper, tighten the banjo bolt to 276 in. lbs. of torque (hard line elbow extends out and back). Use a 10mm socket to secure your new stainless steel brake line mounting brackets to the frame rails using the factory bolts, Slip your new stainless steel brake line up through the new mounting bracket, fasten the factory hard line to it using a 12mm and 17mm wrench, Secure your new stainless steel brake line to the mounting bracket using the retaining clip, Check the fluid level in your master cylinder. Bleed brakes following factory procedure.
74. Install Swaybar bushings into supplied swaybar links, use of a lubricant and a small hammer will assist in this process, install swaybar endlink tubes into swaybar bushings. Install supplied EVO endlinks into swaybar and axle mounts on both driver and passenger side rear. Use supplied hardware.
75. Install rear bumpstop extensions on axle with supplied 5/16" hardware
76. Install new wheels and carefully lower vehicle onto ground
- 77. Install the factory rear swaybar endlinks on the front of the vehicle.**
78. Torque lug nuts to factory specifications
79. Torque all bolts to factory specifications
80. Retorque all hardware after 500 miles and every off road trip.



**2012 or Newer:** Exhaust modifications required on front exhaust loop. Custom exhaust fabrication or below required. Exhaust loop needs to be cut perpendicular to floor straight through factory exhaust loop on both the forward side of the loop and rearward near coupling flange. The loop then needs to be flipped 180 so that the previous front is now welded to the rear and vice versa. Rotate and make sure loop clears front upper control arm bracket and arms before fully welding around to reconnect to exhaust system.



Size	Recommended Torque											
	Grade 2		Grade 5		Grade 8		18-8 S/S		Bronze		Brass	
	Coarse	Fine	Coarse	Fine	Coarse	Fine	Coarse	Fine	Coarse	Fine	Coarse	Fine
#4*	-	-	-	-	-	-	5.2	-	4.8	-	4.3	-
#6*	-	-	-	-	-	-	9.6	-	8.9	-	7.9	-
#8*	-	-	-	-	-	-	19.8	-	18.4	-	16.2	-
#10*	-	-	-	-	-	-	22.8	31.7	21.2	29.3	18.6	25.9
1/4	4	4.7	6.3	7.3	9	10	6.3	7.8	5.7	7.3	5.1	6.4
5/16	8	9	13	14	18	20	11	11.8	10.3	10.9	8.9	9.7
3/8	15	17	23	26	33	37	20	22	18	20	16	18
7/16	24	27	37	41	52	58	31	33	29	31	26	27
1/2	37	41	57	64	80	90	43	45	40	42	35	37
9/16	53	59	82	91	115	129	57	63	53	58	47	51
5/8	73	83	112	128	159	180	93	104	86	96	76	85
3/4	125	138	200	223	282	315	128	124	104	102	118	115
7/8	129	144	322	355	454	501	194	193	178	178	159	158
1†	188	210	483	541	682	764	287	289	265	240	235	212



**EVO-1085 JK Doubled Long Arm Upgrade**

**EVO-1084-35/37 JK Doubled LongArm Kit**



**NOTES:** Cutting and grinding is required to complete the installation. Wheel spacers or aftermarket wheels with a smaller backspacing than factory (4.5" or smaller number are recommended) are required for a complete installation. Aftermarket CV drivelines are recommended. **Recommended: All Vehicles that spend time on salted roads. It is recommended that removal of both threaded collar and joint on all arms. Apply a small amount of Anti Seize on threads and reassemble.**

## Welding on all brackets is recommended.

### BOX #'s 1-2-3 INCLUDED IN FULL DD KIT EVO-1084-35/37 and EVO-1085

QTY	PART#	DESCRIPTION
☐	1	<b>EVO-760009</b> <b>BOX#1 40X9X9</b>
☐	2	EVO-11060B 31LA Tube Steel Front Lower JK
☐	2	EVO-11061B 27LA Tube Steel Rear Lower JK
☐	1	<b>EVO-760009</b> <b>BOX#2 40X9X9</b>
☐	1	EVO-11035B Rear Upper LA DRIVER BLK
☐	1	EVO-11036B Rear Upper LA PASS BLK
☐	1	EVO-11037B Front Upper LA DRIVER BLK
☐	1	EVO-11038B Front Upper LA PASS BLK
☐	1	<b>EVO-760009</b> <b>BOX#3 40X9X9</b>
☐	1	EVO-11008B DRIVER Rear LA Bracket
☐	1	EVO-11010B PASS Rear LA Bracket
☐	1	EVO-11049B DRIVER Front LA Control Arm Bracket
☐	1	EVO-11050B PASS Front LA Control Arm Bracket
☐	3	EVO-11005CZ JK Rear Upper Bolt Tab LA
☐	1	EVO-11006CZ Nut Tab JK Rear DRing, Clear Zinc
☐	1	EVO-770024 LA Upgrade HARDWARE Pack
☐	4	EVO-100563263 Misalignment Spacer
☐	2	EVO-900044 HHCS ½-20 x4.00 Gr* Zinc
☐	4	EVO-900216 SAE Washer ½ Thru Hardend Zinc
☐	2	EVO-900223 Stover Lock Nut ½-20 GrC Zinc
☐	2	EVO-900048 HHCS 9/16-18 1.50 Gr8 Zinc
☐	2	EVO-900217 SAE Washer 9/16 Thru Hardend Zinc
☐	8	EVO-900023 HHCS 3/8-24 x1.50 Gr8 Zinc
☐	8	EVO-900221 Stover Lock Nut 3/8-24 GrC Zinc
☐	4	EVO-900325 HHCS M12, 130MM, 1.75MM, Partial Thread 8.8 Zinc

### BOX #'s 4-5-6 INCLUDED IN FULL DOUBLED KIT EVO-1084-35/37 only

☐	1	<b>EVO-760009</b> <b>BOX#4 40X9X9</b>
☐	2	EVO-20005 3" Front Bumpstop Spacer
☐	2	EVO-900333 Thread Cutting Screw for Metal/ Plastic
☐	1	EVO-11042B Rearward Bracket JK Front Trackbar
☐	1	EVO-11043B JK Front Trackbar Bracket
☐	1	EVO-11044B Driverside Swaybar Link Bracket
☐	1	EVO-770027 Front Trackbar HARDWARE Pack
☐	1	EVO-600089 JK Draglink for Flip Kit
☐	1	EVO-20022CZ JK Steering Flip Adaptor, Clear Zinc
☐	1	EVO-10080B Rear Trackbar Bracket
☐	1	EVO-7700021 Rear RCC Trackbar Bracket HARDWARE Pack
☐	2	EVO-10081B /EVO-10082B Rear 3"/4" Bumpstop BLK
☐	4	EVO-900281 HHCS 5/16-24 x 0.75
☐	8	EVO-900213 SAE Washer 5/16 Thru Hardend Zinc
☐	4	EVO-900220 Stover Lock Nut 5/16-24 GrC Zinc
☐	2	EVO-600067 Brakeline Kit
☐	4	EVO-20032 Swaybar Bushing Tube
☐	4	EVO-600077 Bushing
☐	2	EVO-12029B Front Swaybar Link BLK
☐	4	EVO-900325 HHCS M12, 130MM Length, 1.75MM Pitch
☐	8	EVO-900326 Washer, M12, 24MM OD, 2.3MM-2.7MM
☐	4	EVO-900327 Metric Zinc-Plated Steel Nylon Insert Locknut
☐	1	EVO-770008 Shock Mounting HARDWARE Pack
☐	1	<b>EVO-760015</b> <b>BOX#5 24X12X6</b>
☐	2	EVO-600075/ EVO-600037 Front JK Coil Spring 3" / 4"
☐	1	<b>EVO-760015</b> <b>BOX#6 24X12X6</b>
☐	2	EVO-600076/ EVO-600038 Rear JK Coil Spring 3" / 4"

**NOTE: 2012+ model JK's use 4qty EVO-900325 (HHCS M12, 130mm, 1.75mm Partial Thread 8.8 Zinc ) Cross Member Bolts**

1. Park vehicle on level ground.
2. Elevate front of vehicle securely and safely until tires leave ground.
3. Safely and securely support front frame of vehicle on adjustable jack stands
4. Remove front wheels/tires
5. Remove front swaybar links from vehicle
6. Remove factory brakelines and bracket.
7. Remove bolts retaining brakeline brackets from frame
8. Remove front and rear shocks
9. Remove front and rear swaybar endlinks
10. Remove front and rear springs
11. Remove control arms
12. Cut Front factory control arm brackets as shown on lines in above photos. Removal of the inner portions are only required. Lower front factory need to be trimmed as shown leaving the outer factory portion of the bracket remaining on the vehicle.
13. Support transmission crossmember with adjustable jack stand. Remove two bolts on passenger side that hold in crossmember.
14. Install front passenger side brackets as shown. Mark upper front hole.
15. Remove bracket and drill  $\frac{1}{2}$ " through both sides of the frame.
16. Reinstall bracket and using factory bolts and supplied hardware.
17. Repeat steps on driver side.

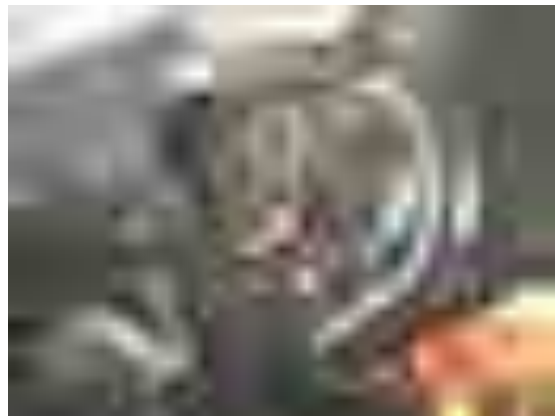

18. Install front control arms upper and lower using factory hardware on factory mounting locations and supplied hardware on EVO Brackets. Front lowers starting length 34.5" and upper starting length 26.375", roughly fully threaded. Front upper arms should bend away from frame. Insert 2 misalignments into each joint on front upper arm. Insert into



frame pocket with bolt going vertical (floor to roof).

**Rear:**

19. Carefully remove gas tank from vehicle. This can be heavy depending on fuel level. Be very careful as this contains highly flammable material.
20. Cut rear body mount as shown in photos. The rear most tab of the body mount needs to be trimmed all the way to the top. Grind all cuts smooth to frame.



21. Remove factory gas tank skid from gas tank.
22. CAREFULLY Cut square recess in outer part of factory gas tank skid plate in middle of support ribs. This allows for room for the lower control arm nut.

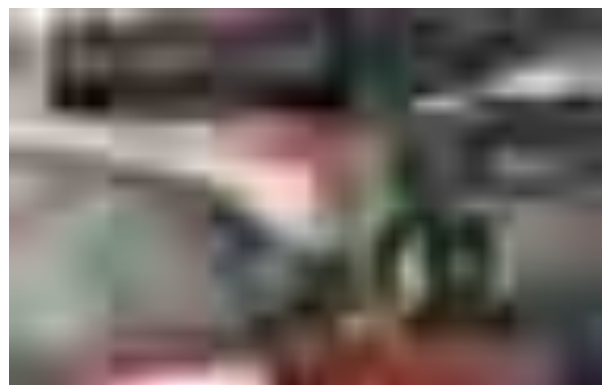

23. Cut factory rear control arm mounts as shown in photos. Grind all cuts smooth to frame.





24. Paint all exposed metal.

25. Remove two factory body mount bolts. The two outer small ones.
26. Install driver and pass side brackets on frame.
27. Tighten two body mount bolts to factory specifications.
28. Mark center of all holes and drill. **All ½" bolt drill through both sides of frame. All others drill through outside ONLY.**  
**For weld on installations, only drill the 9/16" (rear upper arm) holes through the outside of the frame only. Weld all edges of the brackets completely to frame.**
29. Install rear bracket on both driver and passenger side using supplied hardware.
30. Install upper and lower control arms into all remaining control arm mounts on axle and frame. Factory hardware at axle. Adjustable end at axle with crimp tubes up.



31. Use 2 (one each side) of the long flag nuts for the upper rear nuts, inserted through square hole on underside of frame just rear of control arm mount.
32. Adjusts rear lower control arm to 30.5" from center to center and uppers to 20.5" center to center. Roughly fully threaded in...

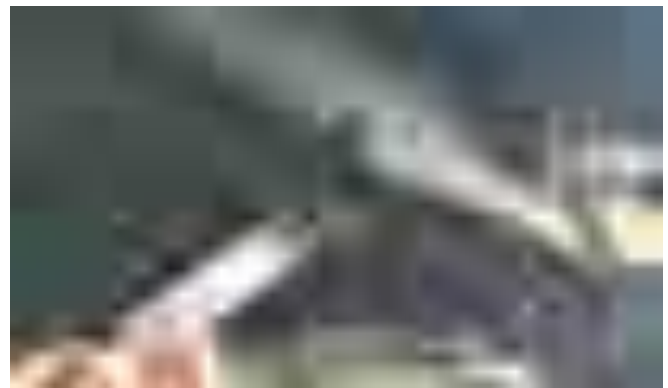

**Full DoubleD kit (Not upgrade):**

33. Remove bolt at trackbar on passenger side at axle
34. Place the smaller supplied bracket into the axle trackbar mount
35. Using the supplied 9/16 bolt, washer and nut and smaller length 5/16 bolt washer and nuts, loosely bolt into place. Do not fully tighten.
36. Place the larger supplied trackbar bracket onto the axle mount on the outside.
37. Using the supplied 9/16 bolt, washer and nut and smaller length 5/16 bolts washer and nuts, loosely bolt into place. Do not fully tighten.
38. Insert the shorter 1/2" bolt with washers and nut for the side bolting the two pieces together.
39. Insert the u-bolt around the axle tube through the mount on the new supplied brackets. Use the supplied 3/8" Locknuts. Make sure to not over tighten.
40. Insert the longer 1/2" bolt with washers and nut through the factory swaybar tab first, then through the supplied trackbar brackets.
41. Tighten all supplied bolts to torque specs at end of these instructions.
42. Remove nut at draglink/steering knuckle connection. Remove Draglink from steering knuckle. This may require you to hit steering knuckle where draglink mounts with small sledge hammer.
43. Remove draglink from factory coupler up towards the pitman arm. You do not want to remove the joint at the pitman arm, just the bar from the coupler. Leave all other components installed as from the factory.
44. With a 13/16" drill bit, drill straight down through factory knuckle where draglink stud was previously mounted. Be as careful as possible to drill straight through knuckle.
45. Using supplied crush sleeve, insert from top down into newly drilled hole in knuckle.
46. Using the supplied draglink, thread into coupler at pitman arm end.
47. Insert the new draglink from the top down through the newly installed crush sleeve at the steering knuckle
48. Using the factory nut removed from the factory draglink, install on to newly installed draglink. Use of a thread locking compound is

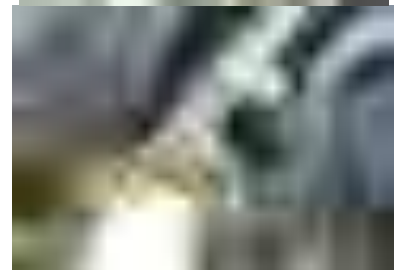
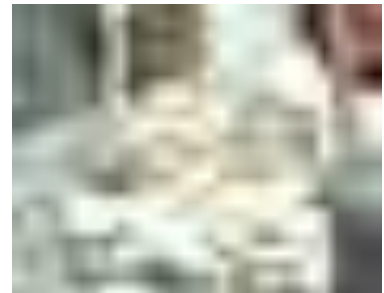
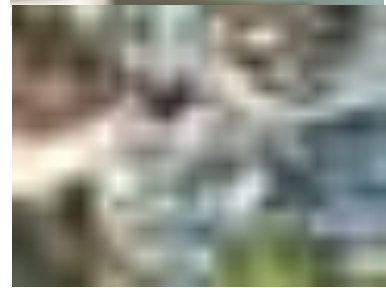
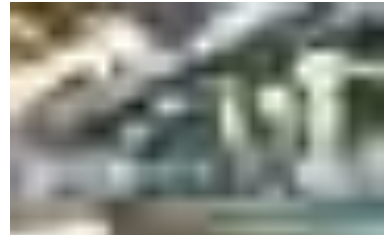
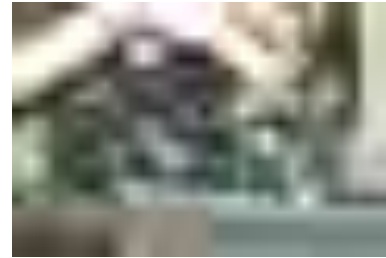

recommended.

49. On driver side, hold up the swaybar extension tab to factory swaybar tab on the inside of factory swaybar tab.
50. With bolt holes at the swaybar tab lined up. Mark the hole that needs to be drill into the coil pocket.
51. With a 5/16" drill bit, drill marked hole into coil pocket. This may require the removal of your brake rotor on the driver side depending on your drilling equipment. If removed, follow factory specifications when removing and reinstalling.
52. With the supplied longer 1/2" bolt, washers and nut, bolt supplied bracket on the inside of the factory bracket.
53. Using the supplied longer 5/16" bolt, washers and nut bolt the supplied bracket to the coil spring mount. This will require the use of the supplied thick spacer tube between the supplied bracket and the coil mount.
54. Reinstall the trackbar to its new higher location with factory hardware
55. On both driver and passenger side front, drill and 5/16" hole in the center of the spring mount on axle.
56. Using supplied self threading bolt, place the bumpstop extensions over the drilled hole on the axle and thread through the center the self threading bolt on both driver and passenger sides
57. Install front coil springs on both driver and passenger sides, smaller pigtail end of spring should be at the frame side (top) with the factory coil spring rubber isolator retained at the top. Make sure lower mount is placed properly into the coil retaining location on the axle
58. Install front shocks top end first (studded end) with one rubber part on the top and one rubber part on the underside of the frame mount.
59. Slowly and carefully raise the axle until the driver side shock mount is line up with the factory axle hole. Install bolt and torque to factory specifications
60. Repeat previous step on passenger side
61. Install supplied brakelines: Cut the thin support tie holding your brake line and ABS line together, separate the main plastic coupling holding your brake line and ABS lines together, Using an 11mm wrench, separate the hard line from the bracket/hose, using a 10mm socket, remove the bolt securing the bracket/hose to the frame rail and set aside the bolt for later use, Use a 10mm socket to secure your new stainless steel brake line mounting bracket to the frame rails using the factory bolt, using a 15mm socket, remove the banjo bolt securing your brake line to it and set it aside, Slip your new stainless steel brake line up through the new mounting bracket and then fasten the hard line to it using a 12mm and 17mm wrench, slip one of the new copper crush washers on to the factory banjo bolt, Insert the factory banjo bolt with copper crush washer on through the new stainless steel brake line and then slip on another copper crush washer, Using a 15mm socket, secure your new stainless steel break line to the break caliper, tighten the banjo bolt to 276 in. lbs. of torque (hard line elbow extends out and back). Secure your new stainless steel brake line to the mounting bracket using the retaining clip, attach your new stainless steel brake line and ABS wiring together using the factory main plastic coupler, zip-tie your new stainless steel brake line and ABS together as they were before, check the fluid level in your master cylinder.



62. Remove rear parking brake cables from mounting bracket on floorboard of vehicle.
63. Remove rear trackbar bolt at axle, leave trackbar bolt at frame installed

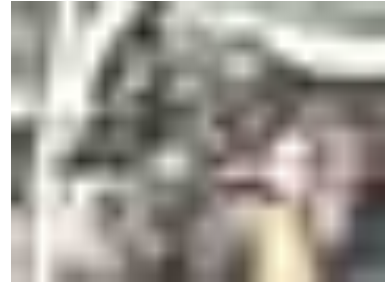
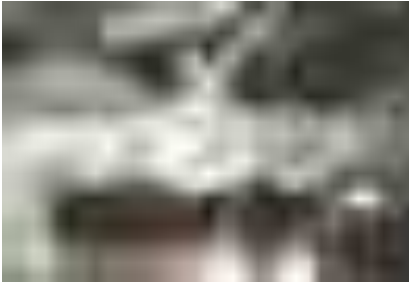
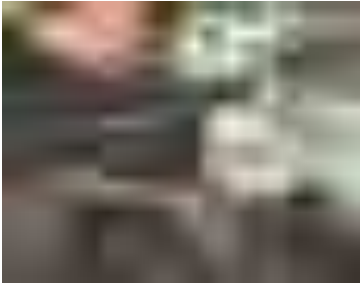

64. Cut factory rear trackbar as shown. Only remove the rear most part of the bracket.
65. Sand all cuts smooth with flat mounting plate.
66. Install rear trackbar bracket as shown with supplied 9/16 bolt and U-bolts (make sure to use the locking nuts on the U-bolts).
67. Weld on rear trackbar bracket to axle where ever possible
68. Reinstall trackbar into new higher location with factory bolt. (torque to factory specifications once vehicle is on ground and at ride height.)
69. Install shocks in upper mounts with supplied bracketry and hardware
70. Install springs into lower axle mount, smaller end of spring should be mounted on the axle side. Larger end of spring goes up while retaining the factory rubber coil spring isolator
71. Slowly and carefully raise axle until lower shock mounts line up with axle mounting bolt holes. Make sure upper coil springs and isolators are properly centered in coil spring perches on top and bottom
72. Install shocks bolts at axle
73. Install rear brakelines: Using a 15mm socket remove the banjo bolt from caliper, Remove the banjo bolt from the brake hose, remove the copper washers and keep them aside you will need to reuse them. Using an 11mm wrench, separate the hard line from the bracket/hose, using a 10mm socket, remove the bolt securing the bracket/hose to the frame rail and set aside the bolt for later use. Install new copper crush washers on to the factory banjo bolt, Insert the factory banjo bolt with copper crush washer on through the new stainless steel brake line, then slip another copper crush washer on. Using a 15mm socket, secure your new stainless steel break line to the break caliper, tighten the banjo bolt to 276 in. lbs. of torque (hard line elbow extends out and back). Use a 10mm socket to secure your new stainless steel brake line mounting brackets to the frame rails using the factory bolts, Slip your new stainless steel brake line up through the new mounting bracket, fasten the factory hard line to it using a 12mm and 17mm wrench, Secure your new stainless steel brake line to the mounting bracket using the retaining clip, Check the fluid level in your master cylinder. Bleed brakes following factory procedure.
74. Install Swaybar bushings into supplied swaybar links, use of a lubricant and a small hammer will assist in this process, install swaybar endlink tubes into swaybar bushings. Install supplied EVO endlinks into swaybar and axle mounts on both driver and passenger side rear. Use supplied hardware.
75. Install rear bumpstop extensions on axle with supplied 5/16" hardware
76. Install new wheels and carefully lower vehicle onto ground
- 77. Install the factory rear swaybar endlinks on the front of the vehicle.**
78. Torque lug nuts to factory specifications
79. Torque all bolts to factory specifications
80. Retorque all hardware after 500 miles and every off road trip.



**2012 or Newer:** Exhaust modifications required on front exhaust loop. Custom exhaust fabrication or below required. Exhaust loop needs to be cut perpendicular to floor straight through factory exhaust loop on both the forward side of the loop and rearward near coupling flange. The loop then needs to be flipped 180 so that the previous front is now welded to the rear and vice versa. Rotate and make sure loop clears front upper control arm bracket and arms before fully welding around to reconnect to exhaust system.



Size	Recommended Torque											
	Grade 2		Grade 5		Grade 8		18-8 S/S		Bronze		Brass	
	Coarse	Fine	Coarse	Fine	Coarse	Fine	Coarse	Fine	Coarse	Fine	Coarse	Fine
#4*	-	-	-	-	-	-	5.2	-	4.8	-	4.3	-
#6*	-	-	-	-	-	-	9.6	-	8.9	-	7.9	-
#8*	-	-	-	-	-	-	19.8	-	18.4	-	16.2	-
#10*	-	-	-	-	-	-	22.8	31.7	21.2	29.3	18.6	25.9
1/4	4	4.7	6.3	7.3	9	10	6.3	7.8	5.7	7.3	5.1	6.4
5/16	8	9	13	14	18	20	11	11.8	10.3	10.9	8.9	9.7
3/8	15	17	23	26	33	37	20	22	18	20	16	18
7/16	24	27	37	41	52	58	31	33	29	31	26	27
1/2	37	41	57	64	80	90	43	45	40	42	35	37
9/16	53	59	82	91	115	129	57	63	53	58	47	51
5/8	73	83	112	128	159	180	93	104	86	96	76	85
3/4	125	138	200	223	282	315	128	124	104	102	118	115
7/8	129	144	322	355	454	501	194	193	178	178	159	158
1†	188	210	483	541	682	764	287	289	265	240	235	212



**EVO-1086KIT**

## **EVO MFG D60 HiSteer Kit**



**This builder kit should be installed by a trained professional with extensive knowledge of solid axle steering geometry. This kit is a universal builders kit, the installer must know how to install it properly working around various axle, suspension, steering ram, and swaybar link combinations and configurations.**

This is a universal steering builder kit for Dana 60 conversions on Jeep JK's. Due to varying hardware requirements per axle manufacturer, hardware is not included. We recommend purchase of 5/8" Grade 8 hardware.

This kit requires high steering arms on both driver and passenger side steering knuckles.

Test steering swipe for needed ram travel before purchasing steering ram system. Most will require 8" travel ram, but test your vehicles configurations first.

**This is a builders kit and requires you the installer to verify proper draglink and trackbar alignment, axle centering at ride height, and a complete interference check. Do not proceed with install if you are not qualified or do not understand these procedures.**

Tack all bracketry together on axle while centered at approximate ride height to vehicle, carefully cycle completed system while tack welded full up and full down, and full right to full left turn checking for any interferences before welding. Address any interference issues prior to proceeding.

Once you have verified no interferences through complete cycling of suspension and steering turn fully weld all bracketry and locations of contact with axle. Torque all bolts to your bolt manufacturers specifications.





## EVO-1087

### EVO NoLimits Manual Rubicon Swaybar Disconnect



#### Bill Of Materials

Part number	Description	Quantity
EVO-11079CZ	EVO Swaybar Actuator Plate Manual CZ	1
EVO-900296	Steel Round Knurled-Rim Knob	1
EVO-900297	Steel Compression Spring	1
EVO-900298	Cap Screw	1
EVO-900300	Jam Nut	1

It is recommended to use an AEV ProCal Module or similar computer programmer to turn off the swaybar light function on your dashboard. Follow directions included with programmer.

**When disconnected, never exceed 20mph. Disconnect for off road use only.**



1. Swing the retention clip to the driver side holding the electronic connector in place. Remove connector.
2. With a 15mm wrench remove the three bolts that connect the actuator to the swaybar.



3. Remove factory swaybar actuator. With a screwdriver push into circular chamber and verify the actuator movement.  
If there is movement proceed to step 4.  
If there is **NO** movement disassemble the swaybar actuator, clean it out, add grease, reassemble, pay attention when disassembling so you will know how to put it back together. Redo step 3.

4. Insert supplied washer into the larger dish inside factory swaybar, making sure it is flat against the bottom.



5. Install the EVO NoLimits Rubi Swaybar Disconnect as shown using factory hardware

6. Zip tie electrical connector up and out of the way to front cross member.
7. **Verify EVO NoLimits Manual Rubicon Swaybar DISCONNECT** start by removing the driverside upper swaybar link from the Rubicon Swaybar.
8. Turn the dial completely in towards the mounting plate to disconnect the swaybar. Verify the swaybar is disconnected by moving the driverside of the swaybar up and down.
9. If there is no movement verify you have done step 3 of these instructions and that the motor actuator is clean and plunges in and out freely.
10. **Verify EVO NoLimits Manual Rubicon Swaybar LOCKED** with the driverside upper swaybar link removed.
11. Turn the dial completely out and away from the mounting plate to connect the swaybar. Verify the swaybar is connected by moving the driverside swaybar up and down. If the swaybar does not move it is locked.
12. If the swaybar does not connect you may need to shorten the EVO NoLimits spring down one single coil and retry step 11. Repeat until proper operation.

To **Disconnect** the EVO NoLimits,  
turn dial completely in, towards mounting plate.

To **Connect** the EVO NoLimits,  
turn dial completely out, away from mounting plate.



## EVO MFG Protek Skid System

**PLEASE READ:** It is recommended that the oil pan be drained before install. Although it is sealed with RTV silicone and will retain to the engine block well with all bolts removed. If you decide to install EVO Skid without draining the oil, do so when oil is cold and at **YOUR OWN RISK**.

1. Recommended: follow manufacturer's instructions on draining engine oil.
2. With oil drained, using a 10mm wrench remove all bolts from oil pan. **DO NOT REMOVE PAN FROM ENGINE.**
3. Carefully install EVO Oil Pan Skid over factory oil pan. Make sure you do not hit or tap on factory pan.
4. Using the two nuts (one on driver front, one on pass rear corners) quickly hand tighten the nuts on these two studs. This will keep the pan and skid held to the engine.



5. Begin to thread **BY HAND** all factory bolts into engine through both the EVO Skid and factory oil pan holes. Make sure to thread all bolts in at least 3 full turns on each bolt before using a wrench. You are threading into aluminum and therefore they are easy to strip. **Thread first few turns by hand is a very important step.**

6. Using a 10mm wrench and/or ratchet begin to thread all bolts until they

begin to touch the EVO Skid. **VERY IMPORTANT: Do not fully tighten any bolts/nuts at this stage.**

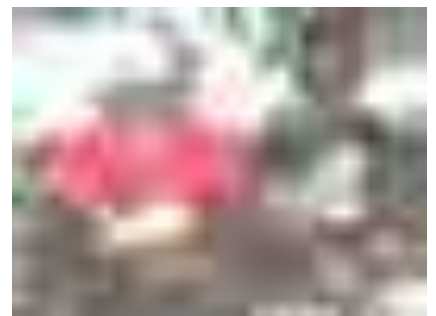

7. With all bolts just slightly touching the EVO Skid, begin to tighten all bolts in a crossing fashion to 85 **in/lbs**. The pan/skid will work its way to become tight and compressing the RTV sealant. You will need to go over all bolts in this crossing fashion a few times until all bolts are tight.
8. Double check that all bolts are tight by starting at one bolt and going around in a circle and ending at the bolt you started with. You may need to do this a couple times aswell. Importance is placed on having all bolts equally tight.
9. With all bolts tight, follow factory specifications on finishing the oil change.

**Before you start engine: MAKE SURE YOU HAVE ENGINE OIL INSTALLED.  
500 miles after install, check for any oil residue or leaks from pan.**

**EVO-1092 2012+ JK Auto Transmission Skid**

**EVO-1104 2012+ JK Manual Transmission Skid**

**Note: Requires install of EVO-1091 Oil Pan Skid for installation**



**First Column: Photos of Manual Skid**

**Second Column: Photos of Auto Skid**

1. Remove two nuts on top of transmission cross member that secure the transmission mount top plate. These are the two nuts that are on each side of the transmission that the treaded stud if facing up.
2. Manuals: With these two nuts removed, slide the EVO transmission skid over these two studs where the studs stick through the two slots cut into the EVO Skid. Thread factory nuts onto studs.
3. Autos: With these two nuts removed, using a floor jack, lift the transfer case about a ½" so the studs are just protruding past the transmission mounting plate. Now slide the EVO skid onto the stud on the driver side. Make sure stud is lined up with the hole in the EVO Skid and then carefully lower transmission/transercase with the jack. On passenger side, install the supplied passenger side mount bracket onto transmission stud, round hole on EVO Bracket at this end, big slot side on top EVO Skid. Install both factory nuts at transmission and supplied 3/8" hardware at mating between EVO Passenger skid mounting bracket and EVO Skid.
4. Using the supplied 7/16" Hardware, install front of skid to oil pan. Transmission skid should be on the lower side of the two tabs on back of the EVO oil pan skid.
5. Tighten all bolts: Factory bolts 37 ft/lbs, 7/16" bolts to 60 ft/lbs, 3/8" bolt to 40 ft/lbs

### **EVO-1093 JK Transmission Crossmember and Exhaust Skid**



1. Remove factory transercase skid (4 bolts: 2 on the center of the transmission cross member, 1 on gas tank, 1 on driver side frame)
2. Some JKs have a skid plate/bar on the front of the transmission cross member, remove this as well. Save Hardware, Factory bar you will not reuse.
3. Remove two bolts on passenger side that attach the gas tank skid to the transmission cross member.

4. Remove only the nut on the driver side lower front control arm at the control arm mount at the frame. Leave bolt installed.
5. Carefully lift EVO Transmission Crossmember/Exhaust Skid up. Pay attention to round tab on driver side with a hole in it. This hole needs to connect with factory lower control arm bolt. Using Factory hardware, thread the two bolts a couple of turn's by hand that hold the gas tank skid to the transmission crossmember. Overlapping the EVO Skid on top of the skid for the gas tank. (Factory gas tank skid portion will be sandwiched between the transmission crossmember and EVO Skid).
6. Thread a couple of turns by hand the nut back onto factory lower control arm sandwiching the EVO Skid against the frame. Thread the center bolt into transmission crossmember.
7. If your JK came with a skid/bar forward of the transmission crossmember use this hardware. If not use supplied EVO hardware. Thread a couple of turns the two forward most holes on the bottom of the frame on both the driver and passenger sides through the EVO Skid.
8. Reinstall the factory transercase skid over the EVO Skid at the transmission crossmember and factory location at the gas tank and driver side frame will factory hardware.
9. Tighten all Hardware: Lower Control Arm Bolt 125 ft/lbs, All others 80 ft/lbs



## EVO-1091B EVO MFG 2012+ JK Oil Pan Skid

**PLEASE READ:** It is recommended that the oil pan be drained before install. Although it is sealed with RTV silicone and will retain to the engine block well with all bolts removed. If you decide to install EVO Skid without draining the oil, do so when oil is cold and at **YOUR OWN RISK**.

1. Recommended: follow manufacturer's instructions on draining engine oil.
2. With oil drained, using a 10mm wrench remove all bolts from oil pan. **DO NOT REMOVE PAN FROM ENGINE.**
3. Carefully install EVO Oil Pan Skid over factory oil pan. Make sure you do not hit or tap on factory pan.
4. Using the two nuts (one on driver front, one on pass rear corners) quickly hand tighten the nuts on these two studs. This will keep the pan and skid held to the engine.



5. Begin to thread **BY HAND** all factory bolts into engine through both the EVO Skid and factory oil pan holes. Make sure to thread all bolts in at least 3 full turns on each bolt before using a wrench. You are threading into aluminum and therefore they are easy to strip. **Thread first few turns by hand is a very important step.**

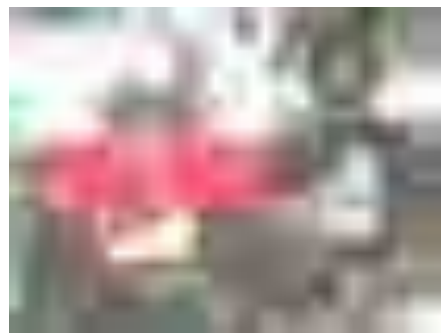

6. Using a 10mm wrench and/or ratchet begin to thread all bolts until they begin to touch the EVO Skid. **VERY IMPORTANT: Do not fully tighten any bolts/nuts at this stage.**
7. With all bolts just slightly touching the EVO Skid, begin to tighten all bolts in a crossing fashion to 85 **in/lbs**. The pan/skid will work its way to become tight and compressing the RTV sealant. You will need to go over all bolts in this crossing fashion a few times until all bolts are tight.
8. Double check that all bolts are tight by starting at one bolt and going around in a circle and ending at the bolt you started with. You may need to do this a couple times aswell. Importance is placed on having all bolts equally tight.
9. With all bolts tight, follow factory specifications on finishing the oil change.

**Before you start engine: MAKE SURE YOU HAVE ENGINE OIL INSTALLED.  
500 miles after install, check for any oil residue or leaks from pan.**





## EVO MFG Protek Skid System

**PLEASE READ:** It is recommended that the oil pan be drained before install. Although it is sealed with RTV silicone and will retain to the engine block well with all bolts removed. If you decide to install EVO Skid without draining the oil, do so when oil is cold and at **YOUR OWN RISK**.

1. Recommended: follow manufacturer's instructions on draining engine oil.
2. With oil drained, using a 10mm wrench remove all bolts from oil pan. **DO NOT REMOVE PAN FROM ENGINE.**
3. Carefully install EVO Oil Pan Skid over factory oil pan. Make sure you do not hit or tap on factory pan.
4. Using the two nuts (one on driver front, one on pass rear corners) quickly hand tighten the nuts on these two studs. This will keep the pan and skid held to the engine.



5. Begin to thread **BY HAND** all factory bolts into engine through both the EVO Skid and factory oil pan holes. Make sure to thread all bolts in at least 3 full turns on each bolt before using a wrench. You are threading into aluminum and therefore they are easy to strip. **Thread first few turns by hand is a very important step.**

6. Using a 10mm wrench and/or ratchet begin to thread all bolts until they

begin to touch the EVO Skid. **VERY IMPORTANT: Do not fully tighten any bolts/nuts at this stage.**

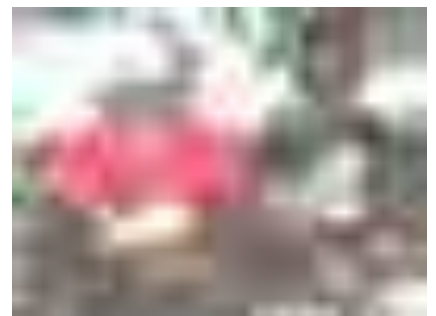

7. With all bolts just slightly touching the EVO Skid, begin to tighten all bolts in a crossing fashion to 85 **in/lbs**. The pan/skid will work its way to become tight and compressing the RTV sealant. You will need to go over all bolts in this crossing fashion a few times until all bolts are tight.
8. Double check that all bolts are tight by starting at one bolt and going around in a circle and ending at the bolt you started with. You may need to do this a couple times aswell. Importance is placed on having all bolts equally tight.
9. With all bolts tight, follow factory specifications on finishing the oil change.

**Before you start engine: MAKE SURE YOU HAVE ENGINE OIL INSTALLED.  
500 miles after install, check for any oil residue or leaks from pan.**

**EVO-1092 2012+ JK Auto Transmission Skid**

**EVO-1104 2012+ JK Manual Transmission Skid**

**Note: Requires install of EVO-1091 Oil Pan Skid for installation**



**First Column: Photos of Manual Skid**

**Second Column: Photos of Auto Skid**

1. Remove two nuts on top of transmission cross member that secure the transmission mount top plate. These are the two nuts that are on each side of the transmission that the treaded stud if facing up.
2. Manuals: With these two nuts removed, slide the EVO transmission skid over these two studs where the studs stick through the two slots cut into the EVO Skid. Thread factory nuts onto studs.
3. Autos: With these two nuts removed, using a floor jack, lift the transfer case about a ½” so the studs are just protruding past the transmission mounting plate. Now slide the EVO skid onto the stud on the driver side. Make sure stud is lined up with the hole in the EVO Skid and then carefully lower transmission/transercase with the jack. On passenger side, install the supplied passenger side mount bracket onto transmission stud, round hole on EVO Bracket at this end, big slot side on top EVO Skid. Install both factory nuts at transmission and supplied 3/8” hardware at mating between EVO Passenger skid mounting bracket and EVO Skid.
4. Using the supplied 7/16” Hardware, install front of skid to oil pan. Transmission skid should be on the lower side of the two tabs on back of the EVO oil pan skid.
5. Tighten all bolts: Factory bolts 37 ft/lbs, 7/16” bolts to 60 ft/lbs, 3/8” bolt to 40 ft/lbs

### **EVO-1093 JK Transmission Crossmember and Exhaust Skid**



1. Remove factory transercase skid (4 bolts: 2 on the center of the transmission cross member, 1 on gas tank, 1 on driver side frame)
2. Some JKs have a skid plate/bar on the front of the transmission cross member, remove this as well. Save Hardware, Factory bar you will not reuse.
3. Remove two bolts on passenger side that attach the gas tank skid to the transmission cross member.

4. Remove only the nut on the driver side lower front control arm at the control arm mount at the frame. Leave bolt installed.
5. Carefully lift EVO Transmission Crossmember/Exhaust Skid up. Pay attention to round tab on driver side with a hole in it. This hole needs to connect with factory lower control arm bolt. Using Factory hardware, thread the two bolts a couple of turn's by hand that hold the gas tank skid to the transmission crossmember. Overlapping the EVO Skid on top of the skid for the gas tank. (Factory gas tank skid portion will be sandwiched between the transmission crossmember and EVO Skid).
6. Thread a couple of turns by hand the nut back onto factory lower control arm sandwiching the EVO Skid against the frame. Thread the center bolt into transmission crossmember.
7. If your JK came with a skid/bar forward of the transmission crossmember use this hardware. If not use supplied EVO hardware. Thread a couple of turns the two forward most holes on the bottom of the frame on both the driver and passenger sides through the EVO Skid.
8. Reinstall the factory transercase skid over the EVO Skid at the transmission crossmember and factory location at the gas tank and driver side frame will factory hardware.
9. Tighten all Hardware: Lower Control Arm Bolt 125 ft/lbs, All others 80 ft/lbs



## EVO MFG Protek Skid System

**PLEASE READ:** It is recommended that the oil pan be drained before install. Although it is sealed with RTV silicone and will retain to the engine block well with all bolts removed. If you decide to install EVO Skid without draining the oil, do so when oil is cold and at **YOUR OWN RISK**.

1. Recommended: follow manufacturer's instructions on draining engine oil.
2. With oil drained, using a 10mm wrench remove all bolts from oil pan. **DO NOT REMOVE PAN FROM ENGINE.**
3. Carefully install EVO Oil Pan Skid over factory oil pan. Make sure you do not hit or tap on factory pan.
4. Using the two nuts (one on driver front, one on pass rear corners) quickly hand tighten the nuts on these two studs. This will keep the pan and skid held to the engine.



5. Begin to thread **BY HAND** all factory bolts into engine through both the EVO Skid and factory oil pan holes. Make sure to thread all bolts in at least 3 full turns on each bolt before using a wrench. You are threading into aluminum and therefore they are easy to strip. **Thread first few turns by hand is a very important step.**

6. Using a 10mm wrench and/or ratchet begin to thread all bolts until they

begin to touch the EVO Skid. **VERY IMPORTANT: Do not fully tighten any bolts/nuts at this stage.**

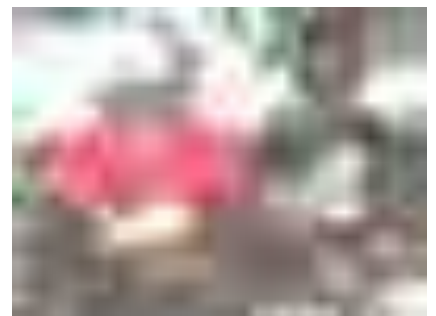

7. With all bolts just slightly touching the EVO Skid, begin to tighten all bolts in a crossing fashion to 85 **in/lbs**. The pan/skid will work its way to become tight and compressing the RTV sealant. You will need to go over all bolts in this crossing fashion a few times until all bolts are tight.
8. Double check that all bolts are tight by starting at one bolt and going around in a circle and ending at the bolt you started with. You may need to do this a couple times aswell. Importance is placed on having all bolts equally tight.
9. With all bolts tight, follow factory specifications on finishing the oil change.

**Before you start engine: MAKE SURE YOU HAVE ENGINE OIL INSTALLED.  
500 miles after install, check for any oil residue or leaks from pan.**

**EVO-1092 2012+ JK Auto Transmission Skid**

**EVO-1104 2012+ JK Manual Transmission Skid**

**Note: Requires install of EVO-1091 Oil Pan Skid for installation**



**First Column: Photos of Manual Skid**

**Second Column: Photos of Auto Skid**

1. Remove two nuts on top of transmission cross member that secure the transmission mount top plate. These are the two nuts that are on each side of the transmission that the treaded stud if facing up.
2. Manuals: With these two nuts removed, slide the EVO transmission skid over these two studs where the studs stick through the two slots cut into the EVO Skid. Thread factory nuts onto studs.
3. Autos: With these two nuts removed, using a floor jack, lift the transfer case about a ½" so the studs are just protruding past the transmission mounting plate. Now slide the EVO skid onto the stud on the driver side. Make sure stud is lined up with the hole in the EVO Skid and then carefully lower transmission/transercase with the jack. On passenger side, install the supplied passenger side mount bracket onto transmission stud, round hole on EVO Bracket at this end, big slot side on top EVO Skid. Install both factory nuts at transmission and supplied 3/8" hardware at mating between EVO Passenger skid mounting bracket and EVO Skid.
4. Using the supplied 7/16" Hardware, install front of skid to oil pan. Transmission skid should be on the lower side of the two tabs on back of the EVO oil pan skid.
5. Tighten all bolts: Factory bolts 37 ft/lbs, 7/16" bolts to 60 ft/lbs, 3/8" bolt to 40 ft/lbs

### **EVO-1093 JK Transmission Crossmember and Exhaust Skid**



1. Remove factory transercase skid (4 bolts: 2 on the center of the transmission cross member, 1 on gas tank, 1 on driver side frame)
2. Some JKs have a skid plate/bar on the front of the transmission cross member, remove this as well. Save Hardware, Factory bar you will not reuse.
3. Remove two bolts on passenger side that attach the gas tank skid to the transmission cross member.

4. Remove only the nut on the driver side lower front control arm at the control arm mount at the frame. Leave bolt installed.
5. Carefully lift EVO Transmission Crossmember/Exhaust Skid up. Pay attention to round tab on driver side with a hole in it. This hole needs to connect with factory lower control arm bolt. Using Factory hardware, thread the two bolts a couple of turn's by hand that hold the gas tank skid to the transmission crossmember. Overlapping the EVO Skid on top of the skid for the gas tank. (Factory gas tank skid portion will be sandwiched between the transmission crossmember and EVO Skid).
6. Thread a couple of turns by hand the nut back onto factory lower control arm sandwiching the EVO Skid against the frame. Thread the center bolt into transmission crossmember.
7. If your JK came with a skid/bar forward of the transmission crossmember use this hardware. If not use supplied EVO hardware. Thread a couple of turns the two forward most holes on the bottom of the frame on both the driver and passenger sides through the EVO Skid.
8. Reinstall the factory transercase skid over the EVO Skid at the transmission crossmember and factory location at the gas tank and driver side frame will factory hardware.
9. Tighten all Hardware: Lower Control Arm Bolt 125 ft/lbs, All others 80 ft/lbs





## **EVO-1095 1.5" JK Leveling Kit**



<b>Part Number</b>	<b>Description</b>	<b>Quantity</b>
EVO-600066	EVO 2" Front Spring	2
EVO-600088	EVO .75" Rear Coil Spacer	2

**NOTES:** This kit is intended to lift the front of your JK approximately 1.25" more than the rear. Removing much of the factory rake (lower in front, higher in rear). Measure your vehicles rake before installing to verify this is the necessary amount of lift that you would like, vehicles vary. This kit is intended to allow for up to 33" tires. Tire and wheel combinations vary and therefore no guarantee is expressed or implied that all combinations will work. You may need to trim, add extended bumpstops, add wheel spacers, high clearance fenders etc to make you specific combination acceptable for your needs.

1. Park vehicle on level ground.
2. Elevate front of vehicle securely and safely until tires leave ground.
3. Safely and securely support front frame of vehicle on adjustable jack stands
4. Remove front wheels/tires
5. Uninstall front swaybar endlinks from axle
6. Remove brakeline mounting bolt at frame on both driver and passenger side.  
Do not disassemble brakeline itself.
7. Remove lower front shock bolts at axle
8. Remove front springs
9. Install front coil springs on both driver and passenger sides, smaller pigtail end of spring should be at the frame side (top) with the factory coil spring rubber isolator retained at the top. Make sure lower mount is placed properly into the coil retaining location on the axle
10. Repeat previous step on passenger side
11. Reinstall shocks into factory location
12. Reinstall brakeline at frame
13. Reinstall Swaybar Endlinks
14. Install wheels
15. Torque lug nuts to factory specifications
16. Carefully lower front of vehicle onto ground
17. With vehicle parked on level ground.
18. Elevate rear of vehicle securely and safely until tires leave ground.
19. Safely and securely support rear frame of vehicle on adjustable jack stands
20. Remove rear wheels/tires
21. Remove rear swaybar links from vehicle from swaybar.

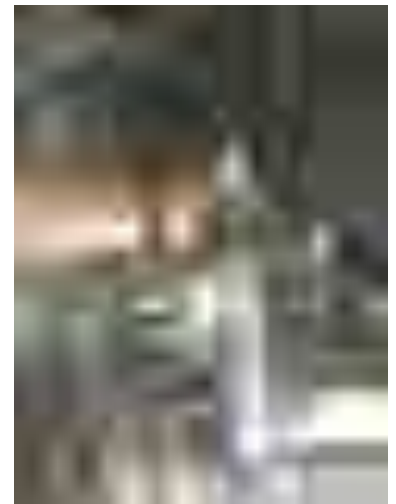
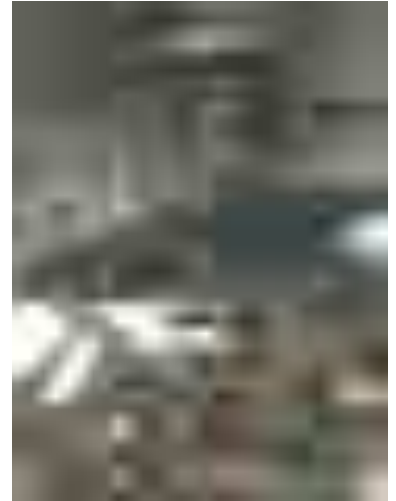

22. Remove brakeline mounting bolt at frame on both driver and passenger side. Do not disassemble brakeline itself.
23. Remove lower rear shock bolts at axle
24. Lower axle with floor jack until supplied coil spring spacer slides onto top of coil springs. Factory isolator stays on top. Top down: Factory Isolator, EVO Spring Spacer, Factory coilspring.

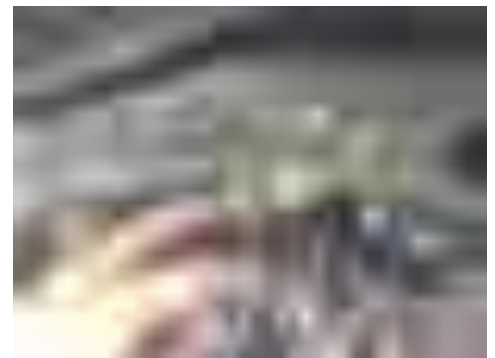

25. Slowly and carefully raise axle with jack until lower shock mounts line up with axle mounting bolt holes. Make sure upper coil springs and isolators are properly centered in coil spring perches on top and bottom
26. Install shocks bolts at axle
27. Reinstall brakeline bracket at the frame
28. Reinstall swaybar endlinks
29. Install wheels
30. Carefully lower vehicle onto ground
31. Torque lug nuts to factory specifications
32. Torque all bolts to factory specifications
33. Retorque all hardware after 500 miles and every off road trip.



**Recommended Torque Specs for all Supplied Hardware.**  
**All Factory Bolts use factory specifications**

Size	Recommended Torque											
	Grade 2		Grade 5		Grade 8		18-8 S/S		Bronze		Brass	
	Coarse	Fine	Coarse	Fine	Coarse	Fine	Coarse	Fine	Coarse	Fine	Coarse	Fine
#4*	-	-	-	-	-	-	5.2	-	4.8	-	4.3	-
#6*	-	-	-	-	-	-	9.6	-	8.9	-	7.9	-
#8*	-	-	-	-	-	-	19.8	-	18.4	-	16.2	-
#10*	-	-	-	-	-	-	22.8	31.7	21.2	29.3	18.6	25.9
1/4	4	4.7	6.3	7.3	9	10	6.3	7.8	5.7	7.3	5.1	6.4
5/16	8	9	13	14	18	20	11	11.8	10.3	10.9	8.9	9.7
3/8	15	17	23	26	33	37	20	22	18	20	16	18
7/16	24	27	37	41	52	58	31	33	29	31	26	27
1/2	37	41	57	64	80	90	43	45	40	42	35	37
9/16	53	59	82	91	115	129	57	63	53	58	47	51
5/8	73	83	112	128	159	180	93	104	86	96	76	85
3/4	125	138	200	223	282	315	128	124	104	102	118	115
7/8	129	144	322	355	454	501	194	193	178	178	159	158
1†	188	210	483	541	682	764	287	289	265	240	235	212



## **EVO-1096 JK Vacuum Pump Relocation Kit**



**Notes:Cutting of the original frame mounting bracket for the pump may be required depending on your winch and bumper combination. Do so if needed.**

1. With front bumper removed and before installation of your aftermarket front bumper and winch. Remove front swaybar mounting bolts at frame on both driver and passenger sides.
2. Remove all hoses from pump and wiring. Wiring has a connection clip that needs to be depressed to disconnect and vacuum line has a green connection fitting that needs to be push down to disconnect.
3. Remove pump from its factory mounting location on inner driver side frame rail.
4. Using supplied #10 bolts install pump as shown in photo to supplied EVO bracket. Do not install wiring or lines at this time.
5. On driver side, using factory swaybar hardware install EVO Pump Mounting bracket.
6. Tighten swaybar bolts to factory specifications.
7. Reconnect all lines to pump as shown. Rearward vacuum line (connects at bottom, backside of pump) should be routed as shown. Around swaybar and under pump. Pull on line from above ties to give it some additional room around swaybar.
8. Push electrical connector pin into inner holes on EVO Pump mounting plate.





## EVO-1097 Jeep JK ARB Air Compressor Bracket



□ 1 EVO-12031B ARB AIR COMPRESSOR MOUNT

1. Loosen two top nuts that mount brake booster to fire wall.
2. Remove driver side rearward most fender bolt (top of fender).
3. Loosen two Allen bolts on the ARB Compressor that go through the blue aluminum heat sink on the outside of the ARB Compressor. Rotate 90 degrees forward as shown. Tighten Allen bolts.
4. Loosen the one bolt on the end of the silver ARB air cylinder. Rotate air cylinder as shown. Re-tighten Bolt. Notice air fitting hole (red plug in photo) is straight forward.
5. Using the supplied ARB Hardware mount compressor to EVO Bracket with bolts inserted from bottom up. 2007-2011 JKs use the forward 4 bolt pattern to mount compressor to bracket, 2012+ use the rearward 4 bolt pattern.
6. 2007-2011s: The large wiring loom along the firewall needs to be disconnected from its mounting clips on firewall, pull them from the firewall studs. There are two, one on each side of master cylinder. This loom should be routed on top of the EVO bracket.

7. Install EVO bracket over the two firewall studs that mount the brake booster.
8. Loosely install the fender bolt into its original location through the EVO Bracket.
9. Tighten the brake booster nuts and fender bolt.
10. Follow ARBs instructions for the remaining installation of the air compressor.



**NOTE: Newer Jeep JK models are equipped with a second horn that will require relocating. EVO MFG has made revisions to our bracket to relocate the second horn. If your bracket does not have the revision, you can easily add the horn relocation yourself by using the provided measurements in the photo as well as a drill with a 1/4" drill bit.**





**EVO-1099**

## **EVO MFG LED Tail Light Kit**



### **Tools and supplies suggested for install:**

Multi Meter or Test Light, Wire Cutters, Crimping tool, Solder and Solder Gun, Electrical Tape, Assorted Shrink Tubing, Zip Ties

### **3-Pin Load Equalizer harness notes:**

When replacing an incandescent turn signal or other flashing light with an LED light, the amp draw of the LED light is so low that sometimes it will flash too slow or too fast, or not flash at all. This load equalizer will level out the amp draw with the flasher module to allow the LED light to flash at the correct speed. For Best Results, use one 3-Pin Load Equalizer on each corner with turn signal lights (left rear, right rear).

Isolate wires around equalizer with isolation material, it will get hot.

**Do not allow wiring to come in direct contact with equalizer body, severe damage to the wire insulation may occur.**



1. Cut the OE taillight plug from the stock taillight leaving as much wire as possible on the plug.
2. Use a multi meter or test light to find your proper circuits.
3. Turn on running lights and probe the OE wires until you find the “hot” running light circuit.
4. Turn on the turn signal for the appropriate side of the vehicle you are working on and probe the wires until you find the “hot” wire for the stop & turn circuit.
5. The black wire on the OE taillight plug is your ground wire.
6. Solder and shrink tube all corresponding wires to their appropriate circuit.
7. Plug the harness into the LED light and test your light for proper function.



**Example photo shown:**

- Black wire from OE tail light plug to White harness wire.
- White with Purple Stripe from OE tail light plug to Black harness wire.
- White with Yellow stripe from OE tail light plug to Red harness wire.
- White with Green stripe ( reverse light hot ), Isolate end of wire and leave unconnected if no reverse lights are used.



**Example photo shown:**

The photo show is to give an optional example of how to bundle your harness for a clean install after you have made all the necessary connections. Ensure that the load equalizer on the harness is clear/ isolated from making contact with any wiring as it gets extremely hot under normal operation.





## EVO-1101 2007-2011 JK Oil Pan Skid (3.8L Gas Engine)

1 EVO-12018B Oil Pan Skid

**PLEASE READ:** It is recommended that the oil pan be drained before install. Although it is sealed with RTV silicone and will retain to the engine block well with all bolts removed. If you decide to install EVO Skid without draining the oil, do so when oil is cold and at YOUR OWN RISK.

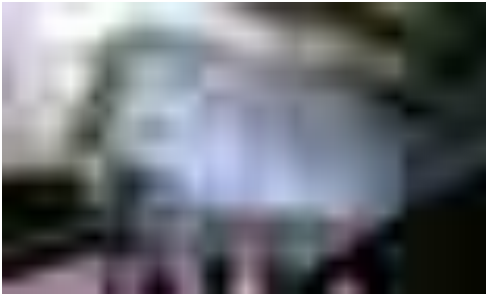
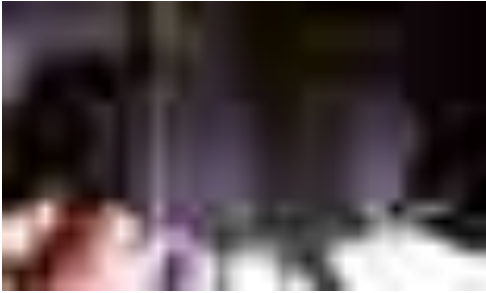

1. Recommended: follow manufacturer's instructions on draining engine oil.
2. With oil drained, using a 10mm wrench remove all bolts from oil pan. **DO NOT REMOVE PAN FROM ENGINE.**
3. Carefully install EVO Oil Pan Skid over factory oil pan. Make sure you do not hit or tap on factory pan.
4. Using the two nuts (one on driver front, one on pass rear corners) quickly hand tighten the nuts on these two studs. This will keep the pan and skid held to the engine.
5. Begin to thread **BY HAND** all factory bolts into engine through both the EVO Skid and factory oil pan holes. Make sure to thread all bolts in at least 3 full turns on each bolt before using a wrench. You are threading into aluminum and therefore they are easy to strip. **Thread first few turns by hand is a very important step.**
6. Using a 10mm wrench and/or ratchet begin to thread all bolts until they begin to touch the EVO Skid. **VERY IMPORTANT: Do not fully tighten any bolts/nuts at this stage.**
7. With all bolts just slightly touching the EVO Skid, begin to tighten all bolts in a crossing fashion to 85 **in/lbs**. The pan/skid will work its way to become tight and compressing the RTV sealant. You will need to go over all bolts in this crossing fashion a few times until all bolts are tight.
8. Double check that all bolts are tight by starting at one bolt and going around in a circle and ending at the bolt you started with. You may need to do this a couple times aswell. Importance is placed on having all bolts equally tight.

9. With all bolts tight, follow factory specifications on finishing the oil change.

**Before you start engine: MAKE SURE YOU HAVE ENGINE OIL INSTALLED.**  
**500 miles after install, check for any oil residue or leaks from pan. Periodically check thereafter**



## EVO MFG Protek Skid System

**PLEASE READ:** It is recommended that the oil pan be drained before install. Although it is sealed with RTV silicone and will retain to the engine block well with all bolts removed. If you decide to install EVO Skid without draining the oil, do so when oil is cold and at **YOUR OWN RISK**.

1. Recommended: follow manufacturer's instructions on draining engine oil.
2. With oil drained, using a 10mm wrench remove all bolts from oil pan. **DO NOT REMOVE PAN FROM ENGINE.**
3. Carefully install EVO Oil Pan Skid over factory oil pan. Make sure you do not hit or tap on factory pan.
4. Using the two nuts (one on driver front, one on pass rear corners) quickly hand tighten the nuts on these two studs. This will keep the pan and skid held to the engine.



5. Begin to thread **BY HAND** all factory bolts into engine through both the EVO Skid and factory oil pan holes. Make sure to thread all bolts in at least 3 full turns on each bolt before using a wrench. You are threading into aluminum and therefore they are easy to strip. **Thread first few turns by hand is a very important step.**

6. Using a 10mm wrench and/or ratchet begin to thread all bolts until they

begin to touch the EVO Skid. **VERY IMPORTANT: Do not fully tighten any bolts/nuts at this stage.**

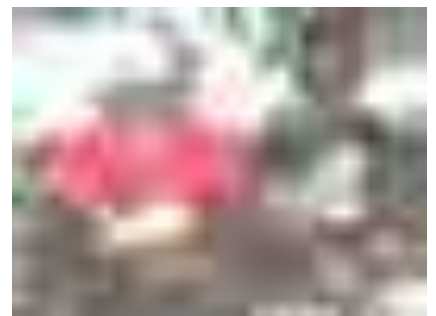

7. With all bolts just slightly touching the EVO Skid, begin to tighten all bolts in a crossing fashion to 85 **in/lbs**. The pan/skid will work its way to become tight and compressing the RTV sealant. You will need to go over all bolts in this crossing fashion a few times until all bolts are tight.
8. Double check that all bolts are tight by starting at one bolt and going around in a circle and ending at the bolt you started with. You may need to do this a couple times aswell. Importance is placed on having all bolts equally tight.
9. With all bolts tight, follow factory specifications on finishing the oil change.

**Before you start engine: MAKE SURE YOU HAVE ENGINE OIL INSTALLED.  
500 miles after install, check for any oil residue or leaks from pan.**

**EVO-1092 2012+ JK Auto Transmission Skid**

**EVO-1104 2012+ JK Manual Transmission Skid**

**Note: Requires install of EVO-1091 Oil Pan Skid for installation**



**First Column: Photos of Manual Skid**

**Second Column: Photos of Auto Skid**

1. Remove two nuts on top of transmission cross member that secure the transmission mount top plate. These are the two nuts that are on each side of the transmission that the treaded stud if facing up.
2. Manuals: With these two nuts removed, slide the EVO transmission skid over these two studs where the studs stick through the two slots cut into the EVO Skid. Thread factory nuts onto studs.
3. Autos: With these two nuts removed, using a floor jack, lift the transfer case about a ½" so the studs are just protruding past the transmission mounting plate. Now slide the EVO skid onto the stud on the driver side. Make sure stud is lined up with the hole in the EVO Skid and then carefully lower transmission/transercase with the jack. On passenger side, install the supplied passenger side mount bracket onto transmission stud, round hole on EVO Bracket at this end, big slot side on top EVO Skid. Install both factory nuts at transmission and supplied 3/8" hardware at mating between EVO Passenger skid mounting bracket and EVO Skid.
4. Using the supplied 7/16" Hardware, install front of skid to oil pan. Transmission skid should be on the lower side of the two tabs on back of the EVO oil pan skid.
5. Tighten all bolts: Factory bolts 37 ft/lbs, 7/16" bolts to 60 ft/lbs, 3/8" bolt to 40 ft/lbs

### **EVO-1093 JK Transmission Crossmember and Exhaust Skid**



1. Remove factory transercase skid (4 bolts: 2 on the center of the transmission cross member, 1 on gas tank, 1 on driver side frame)
2. Some JKs have a skid plate/bar on the front of the transmission cross member, remove this as well. Save Hardware, Factory bar you will not reuse.
3. Remove two bolts on passenger side that attach the gas tank skid to the transmission cross member.

4. Remove only the nut on the driver side lower front control arm at the control arm mount at the frame. Leave bolt installed.
5. Carefully lift EVO Transmission Crossmember/Exhaust Skid up. Pay attention to round tab on driver side with a hole in it. This hole needs to connect with factory lower control arm bolt. Using Factory hardware, thread the two bolts a couple of turn's by hand that hold the gas tank skid to the transmission crossmember. Overlapping the EVO Skid on top of the skid for the gas tank. (Factory gas tank skid portion will be sandwiched between the transmission crossmember and EVO Skid).
6. Thread a couple of turns by hand the nut back onto factory lower control arm sandwiching the EVO Skid against the frame. Thread the center bolt into transmission crossmember.
7. If your JK came with a skid/bar forward of the transmission crossmember use this hardware. If not use supplied EVO hardware. Thread a couple of turns the two forward most holes on the bottom of the frame on both the driver and passenger sides through the EVO Skid.
8. Reinstall the factory transercase skid over the EVO Skid at the transmission crossmember and factory location at the gas tank and driver side frame will factory hardware.
9. Tighten all Hardware: Lower Control Arm Bolt 125 ft/lbs, All others 80 ft/lbs



## EVO-1108

### EVO MFG Front Bolt-On Coilover Kit



□	1	EVO-11090B	Driver Shock Mount Tower
□	1	EVO-11091B	Pass Shock Mount Tower
□	1	EVO-11092B	Pass Lower B/O C/O Mount
□	1	EVO-11092DB	Driver Lower B/O C/O Mount
□	2	EVO-12022CZ	LWR Res Mount
□	2	EVO-12023CZ	Drill Plate B/O C/O Clear Zinc
□	1	EVO-600067	Brakeline Pack
□	1	EVO-770041	F/ Bolt-On Coilover Hardware Pack
□	2	EVO-20005	3" Front Bumpstop Spacer
□	2	EVO-900333	Thread Cutting Screw for Metal/ Plastic
□	4	EVO-20032	Swaybar Bushing Tube
□	4	EVO-600077	Bushing
□	2	EVO-12029B	Front B/O C/O 14 1/2" Swaybar Link
□	1	EVO-770008	Shock Mounting Hardware Pack
□	2	EVO-20031	BOC Spacer Tube
□	4	EVO-900257	SAE 40 Worm Drive Hose Clamp

**Caution: This kit requires drilling and cutting of both metal and plastic. Wheel backspacing adjustments may be required. Due to so many variations and combinations of ACTUAL tire sizes, wheel widths, tire inflation pressures etc.**

**By purchasing this kit you are starting the next level of performance. To install this kit it requires work and finesse. This high quality system will truly enhance your vehicle to another level. Cutting and Grinding required; not bitching and moaning. This is a toy, it should be fun! EVO recommends install by a trained professional.**

**\*At a minimum the JK should be equipped with front adjustable lower control arms to adjust castor. Full control arm packages or long arm upgrade kits and steering upgrades are recommended. Front aftermarket driveline required. 2012+ may require exhaust spacers, relocation, and /or custom to install.**

**\*Re-torque all bolts after first 100 miles**

**High Clearance Fenders recommended**

**\*Re-torque all bolts every 3000 miles and after every off road use.**

1. Elevate front of vehicle securely
2. Remove front wheels
3. Remove battery from battery tray
4. Secure frame with adjustable jack stands
5. Remove front sway bar end links
6. Remove front shocks
7. Remove front springs
8. Insert front plate over factory bump stop. Align at top with existing hole and centered around bump stop. Mark two holes to be drilled.





9. Drill marked holes with 7/16" drill
10. Place front coilover tower over upper front bump stop tube.
11. Rotate reward until contact with plastic wheel well. Note where tower makes contact.
12. Make sure all wires and hoses are out of way.



13. Using a grinder, slowly cut away plastic ribs, test tower and repeat. This will take a few iterations of testing, marking and cutting to clean away the plastic. Only the ribs need to be removed. Continue until tower seats onto top of factory spring perch and shock mount.



14. Install hardware.

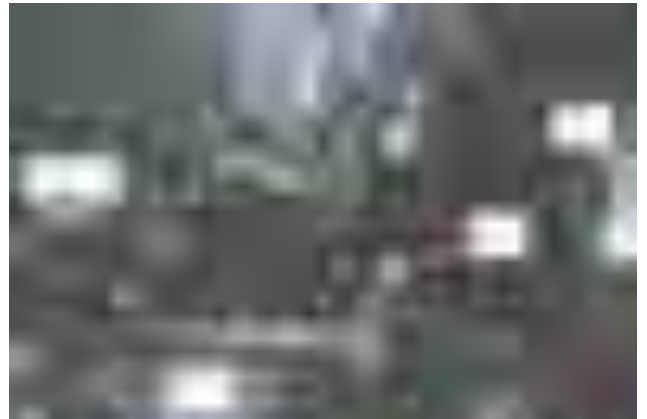

15. Cut lower axle shock mount as shown. This is to give clearance for coilover
16. Install lower axle bracket on the outside (tire side) of factory shock mount.
17. Holes on underside of factory shock mount and side of spring mount may need to be enlarged with drill. Passenger side will need one hole drilled completely.



18. Install EVO lower shock mount with 3/8" hardware on the underside of current shock mount and 5/16" of side of spring mount
19. Remove brake lines.
20. Install new supplied longer brake line and washers to factory hard-line and caliper
21. Install new mounting bracket at frame stacking EVO lower reservoir mount on outside of brake line bracket using factory bolt. Align as shown.



22. Install front coilover where fitting at top of coilover is directed toward rear of JK. Use supplied 1/2" hardware and shock spacers both top and bottom mounts.
23. Use the supplied small spacers for both sides of the top. On the bottom, either use 2 small spacers, or 1 small spacer on the outside and 1 big spacer on the inside depending on factory variances of your specific vehicle.

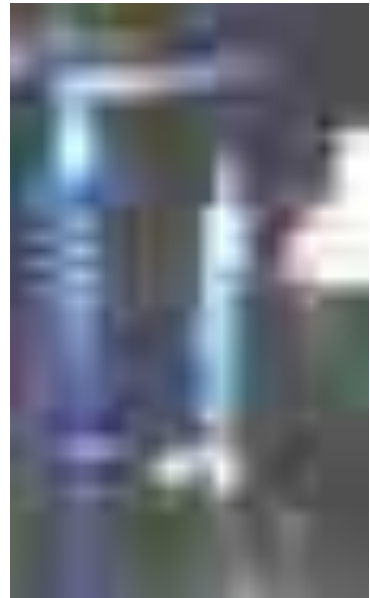

24. On both, driver and passenger side, drill a 5/16" hole in the center of the spring mount on axle.
25. Using supplied self threading bolt, place the bump stop extensions over the drilled hole on the axle and thread through the center with supplied self threading bolt on both driver and passenger sides. Press down on bolt firmly while threading.
26. Twist and raise shock reservoir and place in mount behind rear of upper coilover tower.
27. Using supplied hose clamps mount shock reservoir to both upper and lower mounts.



**When installing in conjunction with an EVO Draglink Flip kit use factory rear swaybar endlinks on the front swaybar to axle connection. If not installing with EVO Draglink Flip kit use supplied swaybar endlinks.**

28. Assemble front swaybar endlinks. Tap hourglass into endlink ends with mallet. Insert sleeve into center of hourglasses.



29. Install endlinks, outside of swaybar, inside of axle mount, as shown.  
30. Install wheels/tires.  
31. Carefully cycle suspension, turning wheels left and right as you go up and down to make sure you have clearance.  
32. Follow factory procedures on bleeding brakes.

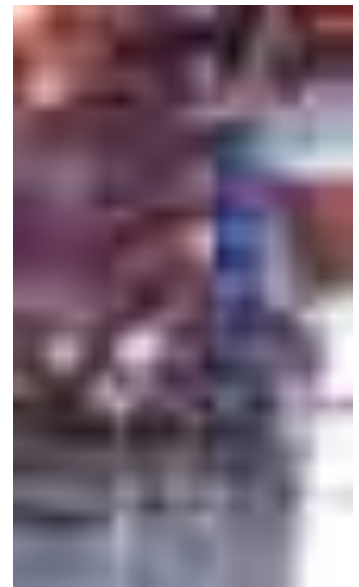

33. Turn spanner nut on top of coil spring, compressing the spring until the distance of the threaded portion between the shock end cap and the spanner is approximately 1.25". This is a starting point. This will vary on a lot of factors (added weight). Screw down if you want more lift, screw up for less. Added vehicle weight will make this vary.

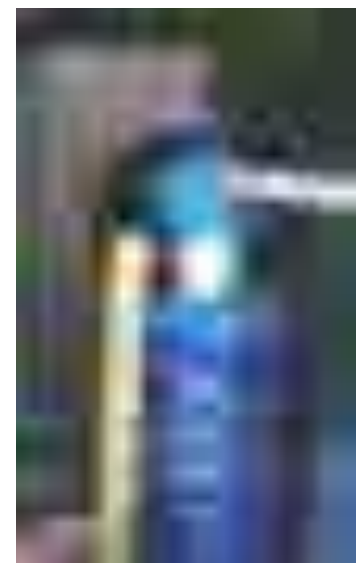

34. Torque wheels to factory or aftermarket specifications.
35. Set vehicle onto ground. Move vehicle forward and backwards a few feet each way while turning wheel to right and left to settle vehicle.
36. Verify desired ride height. If ride height is undesirable, carefully lift front of vehicle by frame until wheels are off the ground and secure it. Turn spanner up to lower ride height, down to raise ride height.
37. Repeat previous steps until desired ride height is achieved
38. Torque all supplied bolts to chart below. All factory bolts to factory specifications. Clean and verify no fluid leaks from brake lines after brake application.

Size	Recommended Torque											
	Grade 2		Grade 5		Grade 8		18-8 S/S		Bronze		Brass	
	Coarse	Fine	Coarse	Fine	Coarse	Fine	Coarse	Fine	Coarse	Fine	Coarse	Fine
<b>1/4</b>	4	4.7	6.3	7.3	9	10	6.3	7.8	5.7	7.3	5.1	6.4
<b>5/16</b>	8	9	13	14	18	20	11	11.8	10.3	10.9	8.9	9.7
<b>3/8</b>	15	17	23	26	33	37	20	22	18	20	16	18
<b>7/16</b>	24	27	37	41	52	58	31	33	29	31	26	27
<b>1/2</b>	37	41	57	64	80	90	43	45	40	42	35	37
<b>9/16</b>	53	59	82	91	115	129	57	63	53	58	47	51
<b>5/8</b>	73	83	112	128	159	180	93	104	86	96	76	85
<b>3/4</b>	125	138	200	223	282	315	128	124	104	102	118	115
<b>7/8</b>	129	144	322	355	454	501	194	193	178	178	159	158
<b>1+</b>	188	210	483	541	682	764	287	289	265	240	235	212

### Set-Up and General Coilover Notes:

Please read before and after installation. Included are things you should know before and after installation of coilovers and some final setup tips to maximize the performance advantages of coilovers. Coilovers can have a tendency to make some sliding sounds when installed on the vehicle. We are stepping into race car parts and some level of sound is expected. There are now 2 springs and a coil isolator attached to the shock body that are consistently sliding up and down while in use. Once final adjustments have been made on spring compression and the vehicle is at a lift/ride height that you are satisfied with. Rotate the top and bottom springs so that that the end of the top and bottom coil that rest on the coil isolator are 180 degrees opposite each other. This will help balance the spring isolator and help the springs rub the shock body less. If this is still unsatisfactory for your needs there are aftermarket spring isolators that can be purchased additionally that will help alleviate this noise. Please give us a call for information on this accessory product.

Spring compression applied with the coil nut on top of the springs will VARY between all vehicles and WILL be different at all 4 corners. This is due to added and or removed weight to the vehicle. The fact that all 4 corners have different weights from the factory, added accessories and or removing factory components all play a part in the vehicles corner weight and are ALL different. Do not be afraid to adjust each coilover spring nut differently on each corner. This is one of the coolest parts of coilovers. You set them up to a lift height that you like. You are not stuck with an amount of lift you get from

whatever springs you end up with. You want it taller turn the coil nut down more or up for less lift. We recommend if 3" or more spring compression is needed to achieve your desired lift height, our HD Coilover Spring set should be used and they are sold separately. Lastly the passenger side is always going to need more spring compression as this side is always heavier due to gas tank and other factory components that are installed passenger side of centerline.

Achievable lift height will vary between each vehicle due to the added and/or reduced weight of the vehicle. Additionally, actual lift is subjective. All Jeeps come from the factory with different heights based on accessories and spring packages etc so they don't even start the same. General lift increases are made by an average and or an understanding of what a 3" or 4" lift etc should be. Add the added and removed accessories weight (front bumper and winch, 37 out back and no rear seat as an example) and we are all over the map. Therefore in order to achieve the desired height you are looking for, spring changes may be needed and are sold separate to our standard kit. We have done extensive testing on these kits with many variables and know we have an excellent spring package straight out of the box, but your vehicle and or needs may vary and therefore a spring change may be needed to accomplish your desired setup. For more lift, EVO-S101F Front HD Coilover Spring Set or EVO-S101R Rear HD Coilover Spring Set.

Once the desired right height is achieved and is sitting on level ground (all ride height/lift changes and or added or removed weight changes will require this process to be readjusted), lower the 2 secondary coil rings (2 silver rings inside the top coil spring) so that they are about 1/2" from the top of the coil isolator (gap). The 2 secondary coil rings can be moved by a tap with a flat head screw driver against the machined groove to break the 2 loose from each other. Once loose, thread them down paying attention that there is a rubber O-ring between that will need to be pushed/rolled down as well. Set the lower ring at about ~1/2" distance from the spring isolator, screw the 2 rings into each other with O-ring set in internal groove of the secondary ring and tap with flathead screw driver to tension them into each other. This 1/2" is a rough dimension and can be adjusted to your liking.



EVO Manufacturing

Jeep Wrangler JK/JKU

JK/JKU Front Bolt-On Coilover Kit

EVO- 1108B





Before starting installation procedure please read <http://evomfg.com>Returns-Warranties-Shipping>

**CAREFULLY READ AND FOLLOW ALL INSTRUCTIONS IN THIS MANUAL AND KEEP FOR FUTURE REFERENCE. IF YOU HAVE ANY QUESTIONS ABOUT THE PRODUCT CALL EVO MANUFACTURING. FAILURE TO FOLLOW GUIDELINES COULD RESULT IN MALFUNCTION OF PARTS OR INJURY. PLEASE HAVE A TRAINED PROFESSIONAL ASSIST WITH OR INSTALL ALL PRODUCTS. INSTALLING EVO MFG PRODUCTS OR KITS DEMANDS SPECIFIC KNOWLEDGE, TOOLS AND EXPERIENCE. GENERAL KNOWLEDGE OF HOW TO USE LATER SPECIFIED TOOLS AND/OR LIMITED EXPERIENCE WITH EVO MFG PRODUCTS MAY NOT BE ENOUGH TO PROPERLY COMPLETE THESE TASKS. SOME OF EVO MFG PRODUCTS MAY REQUIRE TWO OR MORE PEOPLE TO INSTALL SAFELY AND CORRECTLY. DO NOT ATTEMPT ALONE, ALWAYS ENLIST THE HELP OF TRAINED PROFESSIONAL WHEN NEEDED.**

**Notes: Set Up Before installation**

**This kit requires drilling and cutting of both metal and plastic.**

**Wheel backspacing adjustments may be required.**

**Cutting and Grinding required**

**EVO MFG recommends install by a trained professional.**

**\*At a minimum the JK should be equipped with front adjustable lower control arms to adjust castor. Full control arm packages or long arm upgrade kits and steering upgrades are recommended.**

**Front aftermarket driveline required.**

**2012+ may require exhaust spacers, relocation, and /or custom to install.**

**Keep all mounting bolts loose (installed but not torqued) we will torque later at the end of complete installation**

**READ BEFORE INSTALL:**

**\*Re-torque all bolts after first 100 miles. \*Re-torque all bolts every 3000 miles and after every off road use.**

It is generally a good idea to apply Loctite to all threaded bolts.

ALWAYS wear safety glasses and other approved safety gear when working on a vehicle.

All supplied bolts torqued according to chart at end of instruction.

It is recommended all installation be performed by a trained professional. Some modification may have to be done.

Paint all unfinished surfaces after install is complete.



Parts included: Table below shows the front portion of JK EVO Enforcer PRO.

Description	#	Part #	Quantity
Driver Shock Mount Tower	1	EVO-11090B	1
Passenger Shock Mount Tower	2	EVO-11091B	1
Pass Lower B/O C/o Mount	3	EVO-11092B	1
Driver Lower B/O C/O Mount	4	EVO-11092DB	1
LWR Res Mount	5	EVO-12022CZ	2
Drill Plate B/O C/O Clear Zinc	6	EVO-12023CZ	2
Brake Line Pack	7	EVO-600067	1
F/ Bolt-On Coilover Hardware	8	EVO-770041	1
3" Front Bumpstop Spacer	9	EVO-20005	2
Thread Cutting Skrew	10	EVO-900333	2
Swaybar Bushing Tube	11	EVO-20032	4
Swaybar Bushing	12	EVO-600077	4
Fr B/O C/O 14 ½" Swaybar Link	13	EVO-12029B	2
Shock Mounting Hardware Pack	14	EVO-770008	1
BOC Spacer Tube	15	EVO-20031	2
SAE 40 Worm Drive Hose Clamp	16	EVO-900257	4







#### **Recommended Tools:**

- Allen set
  - Impact with standard sockets
  - Sawzall/Cut off wheel or similar
  - Drill and bit
  - Parking Break Tool
- 



#### Safety Steps for installation

- For installing EVO MFG products always use wheel chokes to block rear tires from rolling.
  - Always make sure you have everything necessary ready before install.
  - If you have to, carefully lift front of vehicle by front frame rails extending suspension until tires leave the ground, place frame on approved jack stands for vehicle. Verify all lines/wires are not over extended.
  - Remove tires if needed for easier install.
  - Make sure to wear safety equipment (eye protection, hand protection, foot protection etc.) at all times during installation.
  - Make sure all safety precautions have been taken.
  - Always check and replace any part of vehicle that is worn or broken before starting install.
  - Do not mix anything EVO with weaker alternatives.
  - It is generally a good idea to apply liquid threadlock to all bolts.
  - Tighten included hardware to torque specifications in bottom table unless it is otherwise specified, factory bolts should be torqued to factory Jeep specifications.
- 





## **FRONT INSTALL**

After parking Jeep on a flat surface, chalk wheels and engage parking brake.

1. Carefully lift front of vehicle with jack by frame until tires leave the ground by a few inches minimum.
  2. Carefully and securely set vehicle on weight approved jack stands. It is important that the vehicle is high enough that the tires are at least few inches from the ground as the axle will need to be lowered to remove and install parts.
  3. Remove front wheels/tires
- 





4. Rubicon Models: At differential, carefully pull outward on red clip at axle disconnect until it stops. It should move out about a 1/8". Then depress clip and disconnect clip/connection.
  5. Remove breather hose from differential connection. **Vehicle wiring and hoses vary, make sure all wires, hoses, lines etc from frame to axle are freed up giving ample length to move axle downward as needed before proceeding, verify wiring/hoses etc do not get stretched while lowering axle during this installation.**
- 



6. Remove bolt from both driver and passenger side brake line bracket at axle on rear upper control arm bracket. Free bracket from its detent.
- 





7. Support axle with jacks and remove front sway bar end links from vehicle. (upper stud end on sway bar link has hex key on end of the stud to prevent rotation while removing nut).
- 



8. Remove both driver and passenger side shocks.
- 





9. Lower axle until springs can be removed.  
Remove front springs and upper/lower coil isolators.
- 



10. Disconnect and remove battery by removing the red and black wires with stamped + or – symbols.
- 





11. Insert front plate over factory bump stop. Align at top with existing hole and centered around bump stop.  
Center punch two holes to be drilled.



12. Drill marked holes with 7/16" drill





13. Place front coilover tower over upper front bump stop tube.
  14. Rotate reward until contact with plastic wheel well. Note where tower makes contact.
  15. Make sure all wires and hoses are out of way.
- 



16. Using a grinder, slowly cut away plastic ribs, test tower and repeat. This will take a few iterations of testing, marking and cutting to clean away the plastic. Only the ribs need to be removed. Continue until tower seats onto top of factory spring perch and shock mount.



Be very careful not to grind through plastic completely.

---



17. Install hardware



18. Cut lower axle shock mount as shown. This is to give clearance for coilover.

19. Install lower axle bracket on the outside (tire side) of factory shock mount.

20. Holes on underside of factory shock mount and side of spring mount may need to be enlarged with drill. Passenger side will need one hole drilled completely.



21. Install EVO MFG lower shock mount with 3/8" hardware on the underside of current shock mount and 5/16" of side of spring mount







22. Moving swiftly/carefully separate the hard line from the bracket/hose on frame by holding hardline with a wrench and unscrewing the rubber hose.
  23. Use a wrench to hold hardline and a wrench to secure your new stainless steel brake line to mounting bracket.
- 

**Note:** Bleeding brakes is extremely important to be done properly. Follow factory specifications in doing so. Consultation/should be performed by a trained professional mechanic.

24. Install new copper crush washers on to the factory banjo bolt, Insert the factory banjo bolt with copper crush washer on through the banjo of the new stainless-steel brake line, then slip another copper crush washer on.
- 

**Note:** **Carefully** move line. Do not crimp/pinch line. Always check for leaking fluids and that brakes work correctly.

25. Using a socket, secure your new stainless steel break line to the break caliper using factory hardware, tighten the banjo bolt to 276 in. lbs. of torque (**at caliper hard line elbow extends towards rear of vehicle and angled up as much as possible.**)
- 





26. Install front coilover where fitting at top of coilover is directed toward rear of JK. Use supplied ½" hardware and shock spacers both top and bottom mounts.

27. Use the supplied small spacers for both sides of the top shock bracket. On the bottom shock bracket, either use 2 small spacers, or 1 small spacer on the outside and 1 big spacer on the inside depending on factory variances of your specific vehicle.

---



28. On both, driver and passenger side, drill a 5/16" hole in the center of the spring mount on axle.

29. Using supplied self-threading bolt, place the bump stop extensions over the drilled hole on the axle and thread through the center with supplied self-threading bolt on both driver and passenger sides. Press down on bolt firmly while threading.

---





30. Install new mounting bracket at frame stacking EVO lower reservoir mount on outside of brake line bracket using factory bolt. Align as shown.
31. Twist and raise shock reservoir and place in mount behind rear of upper coilover tower.
32. Using supplied hose clamps mount shock reservoir to both upper and lower mounts.

Repeat on other side.



---

When installing in conjunction with an EVO Draglink Flip kit use factory rear swaybar endlinks on the front swaybar to axle connections. If not installing with EVO Draglink Flip kit use supplied swaybar endlinks.

33. Assemble front swaybar endlinks. Tap hourglass into endlink ends with mallet. Insert sleeve into center of hourglasses.





34. Install endlinks, outside of swaybar, inside of axle mount, as shown.
  35. Install wheels/tires.
  36. Carefully cycle suspension, turning wheels left and right as you go up and down to make sure you have clearance.
  37. Follow factory procedures on bleeding brakes.
- 



38. Turn spanner nut on top of coil spring, compressing the spring until the distance of the threaded portion between the shock end cap and the spanner is approximately 1.25". This is a starting point. This will vary on a lot of factors (added weight and desired lift height). Screw down if you want more lift, screw up for less. Added vehicle weight will make this vary.
- 





39. Set vehicle onto ground. Move vehicle forward and backwards a few feet each way while turning wheel to right and left to settle vehicle.

40. Verify desired ride height. If ride height is undesirable, carefully lift front of vehicle by frame until wheels are off the ground and secure it. Turn spanner up to lower ride height, down to raise ride height

Repeat previous steps until desired ride height is achieved

### **Set-Up and General Coilover Notes:**

Please read **before and after** installation: Included are things you should know before and after installation of coilovers and some final setup tips to maximize the performance advantages of coilovers.

Coilovers can tend to make some sliding sounds while driving. We are stepping into race car parts and some level of sound is to be expected.

Once final adjustments have been made on spring compression and the vehicle is at a lift/ride height that you are satisfied with. Rotate the top and bottom springs so that that each end of the top and bottom coil that rest on the coil slider are 180 degrees opposite each other. This will help balance the coil slider evenly and alleviate some of the associate noises. If this is unsatisfactory for your needs, there are aftermarket spring sliders that can be purchased additionally that will help alleviate this noise. Please give us a call for information on this accessory product.

Spring compression applied with the coil nut on top of the springs will VARY between all vehicles and may be different at all 4 corners. This is due to added and or removed weight to the vehicle. The fact that all 4 corners have different weights from the factory, added accessories and or removing factory components all play a part in the vehicles corner weight and are always varying. Do not be afraid to adjust each coilover spring nut differently on each corner.

We recommend if 3" or more spring compression/preload is needed to achieve your desired lift height, our HD Coilover Spring set should be used, they are sold separately, contact EVO MFG for more information. Lastly the passenger side is heavier and will require slightly more spring compression.

Achievable lift height will vary between each vehicle due to the added and/or reduced weight of the vehicle. Additionally, actual lift is subjective. All Jeeps come from the factory with different heights based on accessories and spring packages etc. General lift increases are made by an average and/or an understanding of what a 3" or 4" lift etc. should be. Therefore in order to achieve the desired height you are looking for, spring changes may be needed and are sold separate to our standard kit.

We have done extensive testing on these kits with many variables and know we have an excellent spring package straight out of the box, but your vehicle and/or needs may vary and therefore a spring change may be needed to accomplish your desired setup.



Once the desired right height is achieved, lower the 2 secondary coil rings (2 silver rings inside the top coil spring) so that there is a  $\frac{1}{2}$ " gap between the bottom of the secondary rings and coil slider. The 2 secondary coil rings can be moved by a tap with a flat head screw driver against the machined groove to break the 2 loose from each other. Once loose, thread them down paying attention that there is a rubber O-ring between that will need to be pushed/rolled down as well. Set the lower ring at about  $\frac{1}{2}$ "-1" distance from the coil slider, tighten the 2 secondary rings towards each other with flathead screw driver and tap of a hammer. This  $\frac{1}{2}$ "-1" is a rough dimension and can be adjusted to your liking and additional payload carrying requirements.





After Install:

- Tighten all bolts securing purchased parts to specified locations.
- After completing installation using provided instructions, go through all steps again to make sure nothing was missed, not tightened or improperly assembled.
- Some components may need to be purchased separately.
- Check turn signals, headlights, fog lights (if applicable), taillights, blinkers and windshield wipers.
- Adjust mirrors, speedometer and headlights if needed.
- Make sure all gauges are fully operational.
- Drive the vehicle slowly for a couple minutes, looking and listening for abnormal noises while driving. After modification of a vehicle there will be differences in driving experiences and capabilities, be mindful of that.
- Inspect and Retorque all Bolts after 500 miles of completed installation and regularly thereafter.
- Some modification may be required.

Recommended Torque:

Size	Grade 2		Grade 5		Grade 8		18-8 S/S	
	Coarse	Fine	Coarse	Fine	Coarse	Fine	Coarse	Fine
<b>#4*</b>	-	-	-	-	-	-	5.2	-
<b>#6*</b>	-	-	-	-	-	-	9.6	-
<b>#8*</b>	-	-	-	-	-	-	19.8	-
<b>#10*</b>	-	-	-	-	-	-	22.8	31.7
<b>1/4</b>	4	4.7	6.3	7.3	9	10	6.3	7.8
<b>5/16</b>	8	9	13	14	18	20	11	11.8
<b>3/8</b>	15	17	23	26	33	37	20	22
<b>7/16</b>	24	27	37	41	52	58	31	33
<b>1/2</b>	37	41	57	64	80	90	43	45
<b>9/16</b>	53	59	82	91	115	129	57	63
<b>5/8</b>	73	83	112	128	159	180	93	104
<b>3/4</b>	125	138	200	223	282	315	128	124
<b>7/8</b>	129	144	322	355	454	501	194	193
<b>1+</b>	188	210	483	541	682	764	287	289



EVO Manufacturing

Jeep Wrangler JK/JKU

JK/JKU Rear Bolt On Coilover Kit

EVO- 1109B







Before starting installation procedure please read <http://evomfg.com>Returns-Warranties-Shipping>

**CAREFULLY READ AND FOLLOW ALL INSTRUCTIONS IN THIS MANUAL AND KEEP FOR FUTURE REFERENCE. IF YOU HAVE ANY QUESTIONS ABOUT THE PRODUCT CALL EVO MANUFACTURING. FAILURE TO FOLLOW GUIDELINES COULD RESULT IN MALFUNCTION OF PARTS OR INJURY. PLEASE HAVE A TRAINED PROFESSIONAL ASSIST WITH OR INSTALL ALL PRODUCTS. INSTALLING EVO MFG PRODUCTS OR KITS DEMANDS SPECIFIC KNOWLEDGE, TOOLS AND EXPERIENCE. GENERAL KNOWLEDGE OF HOW TO USE LATER SPECIFIED TOOLS AND/OR LIMITED EXPERIENCE WITH EVO MFG PRODUCTS MAY NOT BE ENOUGH TO PROPERLY COMPLETE THESE TASKS. SOME OF EVO MFG PRODUCTS MAY REQUIRE TWO OR MORE PEOPLE TO INSTALL SAFELY AND CORRECTLY. DO NOT ATTEMPT ALONE, ALWAYS ENLIST THE HELP OF TRAINED PROFESSIONAL WHEN NEEDED.**

**Notes: Set Up Before installation**

**This kit requires drilling and cutting of both metal and plastic.**

**Wheel backspacing adjustments may be required.**

**Cutting and Grinding required**

**EVO MFG recommends install by a trained professional.**

**\*At a minimum the JK should be equipped with front adjustable lower control arms to adjust castor. Full control arm packages or long arm upgrade kits and steering upgrades are recommended.**

**Aftermarket driveline may be necessary.**

**2012+ may require exhaust spacers, relocation, and /or custom to install.**

**Keep all mounting bolts loose (installed but not torqued) we will torque later at the end of complete installation**

**\*\* IF INSTALLING COMPRESSION ADJUSTABLE SHOCKS. TRIMMING OF REAR EVO BRACKETS AND FACTORY SHOCK MOUNT WILL BE NEEDED AROUND ADJUSTMENT KNOB ON TOP OF SHOCK RESERVOIR. INSTALLER TRIM AS NEEDED \*\***

**READ BEFORE INSTALL:**

**\*Re-torque all bolts after first 100 miles. \*Re-torque all bolts every 3000 miles and after every off road use.**

It is generally a good idea to apply Loctite to all threaded bolts.

ALWAYS wear safety glasses and other approved safety gear when working on a vehicle.

All supplied bolts torqued according to chart at end of instruction.

It is recommended all installation be performed by a trained professional. Some modification may have to be done.

Paint all unfinished surfaces after install is complete.



Parts included: Table below shows JK/JKU Bolt-On Coilover.

Description	#	Part #	Quantity
Rear Driver Mount Coilover	1	EVO-12025B	1
Rear Passenger Mount Coilover	2	EVO-12026B	1
Driver Rockstar Skid	3	EVO-10041B	1
Passenger Rockstar Skid	4	EVO-10040B	1
RCC Trackbar Bracket	5	EVO-12028B	1
RCC Trackbar Bracket Hardware	6	EVO-7700021	1
Brakeline Pack	7	EVO-600067	1





#### **Recommended Tools:**

- Allen set
  - Impact with standard sockets
  - Sawzall/Cut off wheel or similar
  - Drill and ½" bit
- 



#### **Safety Steps for installation**

- For installing EVO MFG products always use wheel chokes to block rear tires from rolling.
  - Always make sure you have everything necessary ready before install.
  - If you have to, carefully lift front of vehicle by front frame rails extending suspension until tires leave the ground, place frame on approved jack stands for vehicle. Verify all lines/wires are not over extended.
  - Remove tires if needed for easier install.
  - Make sure to wear safety equipment (eye protection, hand protection, foot protection etc.) at all times during installation.
  - Make sure all safety precautions have been taken.
  - Always check and replace any part of vehicle that is worn or broken before starting install.
  - Do not mix anything EVO with weaker alternatives.
  - It is generally a good idea to apply liquid threadlock to all bolts.
  - Tighten included hardware to torque specifications in bottom table unless it is otherwise specified, factory bolts should be torqued to factory Jeep specifications.
- 





## **REAR INSTALL**

After parking Jeep on a flat surface, chalk wheels and engage parking brake.

1. Carefully lift rear of vehicle with jack by frame until tires leave the ground by a few inches minimum.
2. Carefully and securely set vehicle on weight approved jack stands. It is important that the vehicle is high enough that the tires are at least few inches from the ground as the axle will need to be lowered to remove and install parts.



Remove Rear wheels/tires

---



3. Rubicon Models: At differential, carefully pull outward on red clip at axle disconnect until it stops. It should move out about a 1/8". Then depress clip and disconnect clip/connection.
  4. Remove breather hose from differential connection. **Vehicle wiring and hoses vary, make sure all wires, hoses, lines etc from frame to axle are freed up giving ample length to move axle downward as needed before proceeding, verify wiring/hoses etc do not get stretched while lowering axle during this installation.**
- 



5. Support axle with jacks and remove rear sway bar end links from vehicle. (upper stud end on sway bar link has hex key on end of the stud to prevent rotation while removing nut).
- 





6. Remove both driver and passenger side shocks.
- 



7. Lower axle until springs can be removed. Remove rear springs and upper/lower coil isolators.
- 





8. Remove parking brake cable.



9. Using 15mm wrench, loosen small nuts on body mounts of JK from the middle of the JK to the rear. 2007-2011 JKs will have 3 sets of body mounts on both sides of frame. 2012+ will have 2 sets.





10. On driver side. Remove bolt  
between frame and body that  
holds gas filler tub to the body.

---



11. Remove muffler from vehicle.  
Loosen clamp just in front of  
axle on the exhaust. Spray  
lubricant on rubber hangers,  
pry hangers from frame.

---







12. On passenger side rear exhaust hanger at frame. Bend hanger upwards about  $\frac{3}{4}$ " with pry bar.

---



13. Using a jack, carefully apply pressure to rear tub lifting rear of body from frame. There needs to be about a  $\frac{1}{2}$ " gap between body and frame.

---





14. With rear body lifted from frame. On both driver and passenger side, insert rear upper strengthening bracket above original shock mount. If difficult to insert. Raise body more. On 2007-2011 JKs the front section of the bracket (2 slotted holes) needs to be inserted under the body mount flange. OR remove these two body mounts.

---



15. After strengthening bracket is inserted. Lower Jack, tighten all body mount bolts.

---





16. Remove driver rear lower control arm bolt at axle.
17. With a paint pen, mark 1.5" down from center of lower control arm hole in the factory axle bracket
18. Carefully, with a Cutoff Wheel/Reciprocating Saw, cut along line, all the way around the control arm pocket and factory swaybar tab.
19. Sand remaining shock tabs, swaybar tab, and cut surface smooth



Paint all exposed metal surfaces

---

20. Install driver side Rock Star as seen in the photo
  21. Install the 3/8" bolts, washers on both sides and lock nuts into the rear two holes on the driver side control arm bracket. The lower 3/8" bolt should be inserted from front to rear. The upper 3/8" should be inserted from the rear to the front.
- 





22. Reinsert lower control arm into the axle mounting brackets
23. Using the factory bolt, reinsert into factory hole with Rock Star brackets in place through control arm

Tighten 3/8" hardware to 40 ft-lbs

Repeat previous Rockstar steps on passenger side

---



24. Remove rear trackbar bolt at axle, leave trackbar bolt at frame installed
  25. Cut factory rear trackbar bracket at axle as shown. **Only remove the rear most part of the bracket.**
  26. Sand all cuts smooth with flat mounting plate.
- 





27. Install rear trackbar bracket as shown with supplied 9/16 bolt and u-bolts.

Recommended: Weld on rear trackbar bracket to axle where ever possible.

28. Reinstall trackbar into new higher location with factory bolt. **(torque to factory specifications once vehicle is on ground and at ride height.)**



29. Install bumpstop extension to axle. Angle of pad should be faced to forward of axle. Use supplied 5/16" hardware.





30. Using supplied socket head bolts, thread two mounting bolts into stock threaded frame bolts. This needs to be done in iterations. Walk the bracket up by threading one bolt a few turns then the other and continue until fully seated. Bolts need to go through 2 holes in the EVO upper strengthening brackets.



31. Install the supplied M10 nuts and washers to the shock bolts above the EVO strengthening plate.

Using bracket as locator.

32. On frame side, just below exhaust hangers, drill hole through frame with 1/2" drill bit.

33. Install supplied 1/2" bolt

**\*\* IF INSTALLING COMPRESSION ADJUSTABLE SHOCKS. TRIMMING OF REAR EVO BRACKETS AND FACTORY SHOCK MOUNT WILL BE NEEDED AROUND ADJUSTMENT KNOB ON TOP OF SHOCK RESERVOIR. INSTALLER TRIM AS NEEDED \*\***





34. Install lower shock mounts to EVO Rockstars using supplied (from hardware bag) larger spacers, one on each side of shock. Do not use small spacers that may be attached to the lower end of the shocks. Use supplied M12 bolt.
- 



35. Remove Factory Swaybar from frame. Two bolts each side.
36. Install EVO MFG Rear Swaybar Relocation Spacers which relocates the OE swaybar back approximately 1". Use the 20MM Black Hex bolts included in the hardware pack to mount the relocation spacers through the larger unthreaded hole and into the OE swaybar mounting location. Use the shorter hex bolts w/ washer to thread swaybar to relocation holes.

Repeat this for driver and passenger sides. (Note the last hole closest to the rear of the vehicle should be threaded).

---





37. Re-Install OE Swaybar to EVO MFG Swaybar Relocation Spacers using 2x 16MM Black Hex Bolts and a washer on each bolt. Repeat on opposite side of vehicle.

---



38. Assemble rear swaybar endlinks. Apply WD40 into endlink tube. Tap hourglass into endlink ends with mallet. Insert sleeve into center of hourglasses.

---







39. Moving swiftly/carefully separate the hard line from the bracket/hose on frame by holding hardline with a wrench and unscrewing the rubber hose.

40. Use a 12mm wrench to hold hardline and a 19mm wrench to secure your new stainless steel brake line to mounting bracket.

---

**Note:** Carefully move line. Do not crimp/pinch line. Always check for leaking fluids and that brakes work correctly. Bleeding brakes is extremely important to be done properly. Follow factory specifications in doing so. Consultation/should be performed by a trained professional mechanic.

---



41. Install new copper crush washers on to the factory banjo bolt, Insert the factory banjo bolt with copper crush washer on through the banjo of the new stainless-steel brake line, then slip another copper crush washer on.

---



42. Using a socket, secure your new stainless steel break line to the break caliper using factory hardware, tighten the banjo bolt to 276 in. lbs. of torque (**at caliper hard line elbow extends towards rear of vehicle and angled up as much as possible.**)

---





**Check the fluid level in your master cylinder. Bleed brakes following factory procedures.**

**Install wheels/tires.**

**Carefully cycle suspension to make sure you have appropriate clearances.**

**Follow factory procedures on bleeding brakes.**

**Reinstall exhaust.**

Turn spanner nut on top of coil spring all the way to the top. This is a starting point. This will vary on a lot of factors (added weight). Screw down if you want more lift. Added vehicle weight will make this vary.

Set vehicle onto ground. Move vehicle forward and backwards a few feet each way while turning wheel to right and left to settle vehicle.

Verify desired ride height. If ride height is undesirable, carefully lift front or rear of vehicle by frame until wheels are off the ground. Turn spanner up to lower ride height, down to raise ride height.

Repeat previous steps until desired ride height is achieved, tighten spanner clamping bolt on coilover after desired ride height is set (all 4 coilovers).



Once vehicle is on the ground, if you have the EVO MFG upper control arms then adjust them out until pinion is facing the transfer case. The angle of your driveshaft and angle of your pinion should have zero degrees difference between the two. **The driveshaft face and pinion face should be parallel with each other.**





**Clean and verify no fluid leaks from brake lines after brake application.  
Torque all bonded rubber control arm and trackbar bushing while vehicle is  
sitting on its weight.**

### **Set-Up and General Coilover Notes:**

Please read **before and after** installation: Included are things you should know before and after installation of coilovers and some final setup tips to maximize the performance advantages of coilovers.

Coilovers can tend to make some sliding sounds while driving. We are stepping into race car parts and some level of sound is to be expected.

Once final adjustments have been made on spring compression and the vehicle is at a lift/ride height that you are satisfied with. Rotate the top and bottom springs so that that each end of the top and bottom coil that rest on the coil slider are 180 degrees opposite each other. This will help balance the coil slider evenly and alleviate some of the associate noises. If this is unsatisfactory for your needs, there are aftermarket spring sliders that can be purchased additionally that will help alleviate this noise. Please give us a call for information on this accessory product.

Spring compression applied with the coil nut on top of the springs will VARY between all vehicles and may be different at all 4 corners. This is due to added and or removed weight to the vehicle. The fact that all 4 corners have different weights from the factory, added accessories and or removing factory components all play a part in the vehicles corner weight and are always varying. Do not be afraid to adjust each coilover spring nut differently on each corner.

We recommend if 3" or more spring compression/preload is needed to achieve your desired lift height, our HD Coilover Spring set should be used, they are sold separately, contact EVO MFG for more information. Lastly the passenger side is heavier and will require slightly more spring compression.

Achievable lift height will vary between each vehicle due to the added and/or reduced weight of the vehicle. Additionally, actual lift is subjective. All Jeeps come from the factory with different heights based on accessories and spring packages etc. General lift increases are made by an average and/or an understanding of what a 3" or 4" lift etc. should be. Therefore in order to achieve the desired height you are looking for, spring changes may be needed and are sold separate to our standard kit.

We have done extensive testing on these kits with many variables and know we have an excellent spring package straight out of the box, but your vehicle and/or needs may vary and therefore a spring change may be needed to accomplish your desired setup.



Once the desired right height is achieved, lower the 2 secondary coil rings (2 silver rings inside the top coil spring) so that there is a  $\frac{1}{2}$ " gap between the bottom of the secondary rings and coil slider. The 2 secondary coil rings can be moved by a tap with a flat head screw driver against the machined groove to break the 2 loose from each other. Once loose, thread them down paying attention that there is a rubber O-ring between that will need to be pushed/rolled down as well. Set the lower ring at about  $\frac{1}{2}$ "-1" distance from the coil slider, tighten the 2 secondary rings towards each other with flathead screw driver and tap of a hammer. This  $\frac{1}{2}$ "-1" is a rough dimension and can be adjusted to your liking and additional payload carrying requirements.





After Install:

- Tighten all bolts securing purchased parts to specified locations.
- After completing installation using provided instructions, go through all steps again to make sure nothing was missed, not tightened or improperly assembled.
- Some components may need to be purchased separately.
- Check turn signals, headlights, fog lights (if applicable), taillights, blinkers and windshield wipers.
- Adjust mirrors, speedometer and headlights if needed.
- Make sure all gauges are fully operational.
- Drive the vehicle slowly for a couple minutes, looking and listening for abnormal noises while driving. After modification of a vehicle there will be differences in driving experiences and capabilities, be mindful of that.
- Inspect and Retorque all Bolts after 500 miles of completed installation and regularly thereafter.
- Some modification may be required.

Recommended Torque:

Size	Grade 2		Grade 5		Grade 8		18-8 S/S	
	Coarse	Fine	Coarse	Fine	Coarse	Fine	Coarse	Fine
<b>#4*</b>	-	-	-	-	-	-	5.2	-
<b>#6*</b>	-	-	-	-	-	-	9.6	-
<b>#8*</b>	-	-	-	-	-	-	19.8	-
<b>#10*</b>	-	-	-	-	-	-	22.8	31.7
<b>1/4</b>	4	4.7	6.3	7.3	9	10	6.3	7.8
<b>5/16</b>	8	9	13	14	18	20	11	11.8
<b>3/8</b>	15	17	23	26	33	37	20	22
<b>7/16</b>	24	27	37	41	52	58	31	33
<b>1/2</b>	37	41	57	64	80	90	43	45
<b>9/16</b>	53	59	82	91	115	129	57	63
<b>5/8</b>	73	83	112	128	159	180	93	104
<b>3/4</b>	125	138	200	223	282	315	128	124
<b>7/8</b>	129	144	322	355	454	501	194	193
<b>1+</b>	188	210	483	541	682	764	287	289



EVO Manufacturing

Jeep Wrangler JK/JKU

JK/JKU Rear Bolt On Coilover Kit

EVO- 1109B





Before starting installation procedure please read <http://evomfg.com>Returns-Warranties-Shipping>

**CAREFULLY READ AND FOLLOW ALL INSTRUCTIONS IN THIS MANUAL AND KEEP FOR FUTURE REFERENCE. IF YOU HAVE ANY QUESTIONS ABOUT THE PRODUCT CALL EVO MANUFACTURING. FAILURE TO FOLLOW GUIDELINES COULD RESULT IN MALFUNCTION OF PARTS OR INJURY. PLEASE HAVE A TRAINED PROFESSIONAL ASSIST WITH OR INSTALL ALL PRODUCTS. INSTALLING EVO MFG PRODUCTS OR KITS DEMANDS SPECIFIC KNOWLEDGE, TOOLS AND EXPERIENCE. GENERAL KNOWLEDGE OF HOW TO USE LATER SPECIFIED TOOLS AND/OR LIMITED EXPERIENCE WITH EVO MFG PRODUCTS MAY NOT BE ENOUGH TO PROPERLY COMPLETE THESE TASKS. SOME OF EVO MFG PRODUCTS MAY REQUIRE TWO OR MORE PEOPLE TO INSTALL SAFELY AND CORRECTLY. DO NOT ATTEMPT ALONE, ALWAYS ENLIST THE HELP OF TRAINED PROFESSIONAL WHEN NEEDED.**

**Notes: Set Up Before installation**

**This kit requires drilling and cutting of both metal and plastic.**

**Wheel backspacing adjustments may be required.**

**Cutting and Grinding required**

**EVO MFG recommends install by a trained professional.**

**\*At a minimum the JK should be equipped with front adjustable lower control arms to adjust castor. Full control arm packages or long arm upgrade kits and steering upgrades are recommended.**

**Aftermarket driveline may be necessary.**

**2012+ may require exhaust spacers, relocation, and /or custom to install.**

**Keep all mounting bolts loose (installed but not torqued) we will torque later at the end of complete installation**

**\*\* IF INSTALLING COMPRESSION ADJUSTABLE SHOCKS. TRIMMING OF REAR EVO BRACKETS AND FACTORY SHOCK MOUNT WILL BE NEEDED AROUND ADJUSTMENT KNOB ON TOP OF SHOCK RESERVOIR. INSTALLER TRIM AS NEEDED \*\***

**READ BEFORE INSTALL:**

**\*Re-torque all bolts after first 100 miles. \*Re-torque all bolts every 3000 miles and after every off road use.**

It is generally a good idea to apply Loctite to all threaded bolts.

ALWAYS wear safety glasses and other approved safety gear when working on a vehicle.

All supplied bolts torqued according to chart at end of instruction.

It is recommended all installation be performed by a trained professional. Some modification may have to be done.

Paint all unfinished surfaces after install is complete.



Parts included: Table below shows JK/JKU Bolt-On Coilover.

Description	#	Part #	Quantity
Rear Driver Mount Coilover	1	EVO-12025B	1
Rear Passenger Mount Coilover	2	EVO-12026B	1
Driver Rockstar Skid	3	EVO-10041B	1
Passenger Rockstar Skid	4	EVO-10040B	1
RCC Trackbar Bracket	5	EVO-12028B	1
RCC Trackbar Bracket Hardware	6	EVO-7700021	1
Brakeline Pack	7	EVO-600067	1







#### **Recommended Tools:**

- Allen set
  - Impact with standard sockets
  - Sawzall/Cut off wheel or similar
  - Drill and ½" bit
- 



#### **Safety Steps for installation**

- For installing EVO MFG products always use wheel chokes to block rear tires from rolling.
  - Always make sure you have everything necessary ready before install.
  - If you have to, carefully lift front of vehicle by front frame rails extending suspension until tires leave the ground, place frame on approved jack stands for vehicle. Verify all lines/wires are not over extended.
  - Remove tires if needed for easier install.
  - Make sure to wear safety equipment (eye protection, hand protection, foot protection etc.) at all times during installation.
  - Make sure all safety precautions have been taken.
  - Always check and replace any part of vehicle that is worn or broken before starting install.
  - Do not mix anything EVO with weaker alternatives.
  - It is generally a good idea to apply liquid threadlock to all bolts.
  - Tighten included hardware to torque specifications in bottom table unless it is otherwise specified, factory bolts should be torqued to factory Jeep specifications.
- 





## **REAR INSTALL**

After parking Jeep on a flat surface, chalk wheels and engage parking brake.

1. Carefully lift rear of vehicle with jack by frame until tires leave the ground by a few inches minimum.
2. Carefully and securely set vehicle on weight approved jack stands. It is important that the vehicle is high enough that the tires are at least few inches from the ground as the axle will need to be lowered to remove and install parts.



Remove Rear wheels/tires

---



3. Rubicon Models: At differential, carefully pull outward on red clip at axle disconnect until it stops. It should move out about a 1/8". Then depress clip and disconnect clip/connection.
  4. Remove breather hose from differential connection. **Vehicle wiring and hoses vary, make sure all wires, hoses, lines etc from frame to axle are freed up giving ample length to move axle downward as needed before proceeding, verify wiring/hoses etc do not get stretched while lowering axle during this installation.**
- 



5. Support axle with jacks and remove rear sway bar end links from vehicle. (upper stud end on sway bar link has hex key on end of the stud to prevent rotation while removing nut).
- 





6. Remove both driver and passenger side shocks.
- 



7. Lower axle until springs can be removed. Remove rear springs and upper/lower coil isolators.
- 





8. Remove parking brake cable.



9. Using 15mm wrench, loosen small nuts on body mounts of JK from the middle of the JK to the rear. 2007-2011 JKs will have 3 sets of body mounts on both sides of frame. 2012+ will have 2 sets.





10. On driver side. Remove bolt  
between frame and body that  
holds gas filler tub to the body.

---



11. Remove muffler from vehicle.  
Loosen clamp just in front of  
axle on the exhaust. Spray  
lubricant on rubber hangers,  
pry hangers from frame.

---





12. On passenger side rear exhaust hanger at frame. Bend hanger upwards about  $\frac{3}{4}$ " with pry bar.

---



13. Using a jack, carefully apply pressure to rear tub lifting rear of body from frame. There needs to be about a  $\frac{1}{2}$ " gap between body and frame.

---





14. With rear body lifted from frame. On both driver and passenger side, insert rear upper strengthening bracket above original shock mount. If difficult to insert. Raise body more. On 2007-2011 JKs the front section of the bracket (2 slotted holes) needs to be inserted under the body mount flange. OR remove these two body mounts.

---



15. After strengthening bracket is inserted. Lower Jack, tighten all body mount bolts.

---







16. Remove driver rear lower control arm bolt at axle.
17. With a paint pen, mark 1.5" down from center of lower control arm hole in the factory axle bracket
18. Carefully, with a Cutoff Wheel/Reciprocating Saw, cut along line, all the way around the control arm pocket and factory swaybar tab.
19. Sand remaining shock tabs, swaybar tab, and cut surface smooth



Paint all exposed metal surfaces

---

20. Install driver side Rock Star as seen in the photo
  21. Install the 3/8" bolts, washers on both sides and lock nuts into the rear two holes on the driver side control arm bracket. The lower 3/8" bolt should be inserted from front to rear. The upper 3/8" should be inserted from the rear to the front.
- 





22. Reinsert lower control arm into the axle mounting brackets
23. Using the factory bolt, reinsert into factory hole with Rock Star brackets in place through control arm

Tighten 3/8" hardware to 40 ft-lbs

Repeat previous Rockstar steps on passenger side

---



24. Remove rear trackbar bolt at axle, leave trackbar bolt at frame installed
  25. Cut factory rear trackbar bracket at axle as shown. **Only remove the rear most part of the bracket.**
  26. Sand all cuts smooth with flat mounting plate.
- 





27. Install rear trackbar bracket as shown with supplied 9/16 bolt and u-bolts.

Recommended: Weld on rear trackbar bracket to axle where ever possible.

28. Reinstall trackbar into new higher location with factory bolt. **(torque to factory specifications once vehicle is on ground and at ride height.)**



29. Install bumpstop extension to axle. Angle of pad should be faced to forward of axle. Use supplied 5/16" hardware.





30. Using supplied socket head bolts, thread two mounting bolts into stock threaded frame bolts. This needs to be done in iterations. Walk the bracket up by threading one bolt a few turns then the other and continue until fully seated. Bolts need to go through 2 holes in the EVO upper strengthening brackets.



31. Install the supplied M10 nuts and washers to the shock bolts above the EVO strengthening plate.

Using bracket as locator.

32. On frame side, just below exhaust hangers, drill hole through frame with 1/2" drill bit.

33. Install supplied 1/2" bolt

**\*\* IF INSTALLING COMPRESSION ADJUSTABLE SHOCKS. TRIMMING OF REAR EVO BRACKETS AND FACTORY SHOCK MOUNT WILL BE NEEDED AROUND ADJUSTMENT KNOB ON TOP OF SHOCK RESERVOIR. INSTALLER TRIM AS NEEDED \*\***





34. Install lower shock mounts to EVO Rockstars using supplied (from hardware bag) larger spacers, one on each side of shock. Do not use small spacers that may be attached to the lower end of the shocks. Use supplied M12 bolt.
- 



35. Remove Factory Swaybar from frame. Two bolts each side.
36. Install EVO MFG Rear Swaybar Relocation Spacers which relocates the OE swaybar back approximately 1". Use the 20MM Black Hex bolts included in the hardware pack to mount the relocation spacers through the larger unthreaded hole and into the OE swaybar mounting location. Use the shorter hex bolts w/ washer to thread swaybar to relocation holes.

Repeat this for driver and passenger sides. (Note the last hole closest to the rear of the vehicle should be threaded).

---





37. Re-Install OE Swaybar to EVO MFG Swaybar Relocation Spacers using 2x 16MM Black Hex Bolts and a washer on each bolt. Repeat on opposite side of vehicle.

---



38. Assemble rear swaybar endlinks. Apply WD40 into endlink tube. Tap hourglass into endlink ends with mallet. Insert sleeve into center of hourglasses.

---





39. Moving swiftly/carefully separate the hard line from the bracket/hose on frame by holding hardline with a wrench and unscrewing the rubber hose.

40. Use a 12mm wrench to hold hardline and a 19mm wrench to secure your new stainless steel brake line to mounting bracket.

---

**Note:** Carefully move line. Do not crimp/pinch line. Always check for leaking fluids and that brakes work correctly. Bleeding brakes is extremely important to be done properly. Follow factory specifications in doing so. Consultation/should be performed by a trained professional mechanic.

---



41. Install new copper crush washers on to the factory banjo bolt, Insert the factory banjo bolt with copper crush washer on through the banjo of the new stainless-steel brake line, then slip another copper crush washer on.

---



42. Using a socket, secure your new stainless steel break line to the break caliper using factory hardware, tighten the banjo bolt to 276 in. lbs. of torque (**at caliper hard line elbow extends towards rear of vehicle and angled up as much as possible.**)

---





**Check the fluid level in your master cylinder. Bleed brakes following factory procedures.**

**Install wheels/tires.**

**Carefully cycle suspension to make sure you have appropriate clearances.**

**Follow factory procedures on bleeding brakes.**

**Reinstall exhaust.**

Turn spanner nut on top of coil spring all the way to the top. This is a starting point. This will vary on a lot of factors (added weight). Screw down if you want more lift. Added vehicle weight will make this vary.

Set vehicle onto ground. Move vehicle forward and backwards a few feet each way while turning wheel to right and left to settle vehicle.

Verify desired ride height. If ride height is undesirable, carefully lift front or rear of vehicle by frame until wheels are off the ground. Turn spanner up to lower ride height, down to raise ride height.

Repeat previous steps until desired ride height is achieved, tighten spanner clamping bolt on coilover after desired ride height is set (all 4 coilovers).



Once vehicle is on the ground, if you have the EVO MFG upper control arms then adjust them out until pinion is facing the transfer case. The angle of your driveshaft and angle of your pinion should have zero degrees difference between the two. **The driveshaft face and pinion face should be parallel with each other.**







**Clean and verify no fluid leaks from brake lines after brake application.  
Torque all bonded rubber control arm and trackbar bushing while vehicle is  
sitting on its weight.**

### **Set-Up and General Coilover Notes:**

Please read **before and after** installation: Included are things you should know before and after installation of coilovers and some final setup tips to maximize the performance advantages of coilovers.

Coilovers can tend to make some sliding sounds while driving. We are stepping into race car parts and some level of sound is to be expected.

Once final adjustments have been made on spring compression and the vehicle is at a lift/ride height that you are satisfied with. Rotate the top and bottom springs so that that each end of the top and bottom coil that rest on the coil slider are 180 degrees opposite each other. This will help balance the coil slider evenly and alleviate some of the associate noises. If this is unsatisfactory for your needs, there are aftermarket spring sliders that can be purchased additionally that will help alleviate this noise. Please give us a call for information on this accessory product.

Spring compression applied with the coil nut on top of the springs will VARY between all vehicles and may be different at all 4 corners. This is due to added and or removed weight to the vehicle. The fact that all 4 corners have different weights from the factory, added accessories and or removing factory components all play a part in the vehicles corner weight and are always varying. Do not be afraid to adjust each coilover spring nut differently on each corner.

We recommend if 3" or more spring compression/preload is needed to achieve your desired lift height, our HD Coilover Spring set should be used, they are sold separately, contact EVO MFG for more information. Lastly the passenger side is heavier and will require slightly more spring compression.

Achievable lift height will vary between each vehicle due to the added and/or reduced weight of the vehicle. Additionally, actual lift is subjective. All Jeeps come from the factory with different heights based on accessories and spring packages etc. General lift increases are made by an average and/or an understanding of what a 3" or 4" lift etc. should be. Therefore in order to achieve the desired height you are looking for, spring changes may be needed and are sold separate to our standard kit.

We have done extensive testing on these kits with many variables and know we have an excellent spring package straight out of the box, but your vehicle and/or needs may vary and therefore a spring change may be needed to accomplish your desired setup.



Once the desired right height is achieved, lower the 2 secondary coil rings (2 silver rings inside the top coil spring) so that there is a  $\frac{1}{2}$ " gap between the bottom of the secondary rings and coil slider. The 2 secondary coil rings can be moved by a tap with a flat head screw driver against the machined groove to break the 2 loose from each other. Once loose, thread them down paying attention that there is a rubber O-ring between that will need to be pushed/rolled down as well. Set the lower ring at about  $\frac{1}{2}$ "-1" distance from the coil slider, tighten the 2 secondary rings towards each other with flathead screw driver and tap of a hammer. This  $\frac{1}{2}$ "-1" is a rough dimension and can be adjusted to your liking and additional payload carrying requirements.





After Install:

- Tighten all bolts securing purchased parts to specified locations.
- After completing installation using provided instructions, go through all steps again to make sure nothing was missed, not tightened or improperly assembled.
- Some components may need to be purchased separately.
- Check turn signals, headlights, fog lights (if applicable), taillights, blinkers and windshield wipers.
- Adjust mirrors, speedometer and headlights if needed.
- Make sure all gauges are fully operational.
- Drive the vehicle slowly for a couple minutes, looking and listening for abnormal noises while driving. After modification of a vehicle there will be differences in driving experiences and capabilities, be mindful of that.
- Inspect and Retorque all Bolts after 500 miles of completed installation and regularly thereafter.
- Some modification may be required.

Recommended Torque:

Size	Grade 2		Grade 5		Grade 8		18-8 S/S	
	Coarse	Fine	Coarse	Fine	Coarse	Fine	Coarse	Fine
<b>#4*</b>	-	-	-	-	-	-	5.2	-
<b>#6*</b>	-	-	-	-	-	-	9.6	-
<b>#8*</b>	-	-	-	-	-	-	19.8	-
<b>#10*</b>	-	-	-	-	-	-	22.8	31.7
<b>1/4</b>	4	4.7	6.3	7.3	9	10	6.3	7.8
<b>5/16</b>	8	9	13	14	18	20	11	11.8
<b>3/8</b>	15	17	23	26	33	37	20	22
<b>7/16</b>	24	27	37	41	52	58	31	33
<b>1/2</b>	37	41	57	64	80	90	43	45
<b>9/16</b>	53	59	82	91	115	129	57	63
<b>5/8</b>	73	83	112	128	159	180	93	104
<b>3/4</b>	125	138	200	223	282	315	128	124
<b>7/8</b>	129	144	322	355	454	501	194	193
<b>1+</b>	188	210	483	541	682	764	287	289



## EVO-1112B/ EVO-1112AL JK Quarter Pounder Front Bumper



### EVO-1112B

□	1	EVO-10038B	EVO 1/4 POUNDER JK Front Stubby Bumper
□	4	EVO-10037B	EVO 1/4 Pounder Front Bumper Plate JK Black
□	1	EVO-770014	1/4 Pounder Hardware Pack
□	1	EVO-12033B	Jog Plate
□	1	EVO-770045	Jog Plate Hardware Pack

### EVO-1112AL

□	4	EVO-10037AL	Spacer Plate, JK Front Bumper (ALUM)
□	1	EVO-10038AL	¼ Pounder, JK Front Stubby Bumper (ALUM)
□	1	EVO-10039AL	Front Bumper Jog Plate (ALUM)
□	1	EVO-770014	¼ Pounder Hardware Pack
□	1	EVO-770044	Front Bumper Jog Plate Hardware Pack

Please do not discard the hardware pack containing the items pictured to the right. This is the EVO Jog Plate and hardware required when mounting your winch fairlead.



**Notes: On aluminum version EVO-1112AL when coating or painting heat should not be applied due to aluminum properties.**

**This kit requires cutting to gain added ground clearance and approach angles. Rubicon models see supplement instructions**

1. Remove factory front bumper by removing the 8 nuts on the inside of the bumper.



2. Remove upper factory plastic in front of grill.

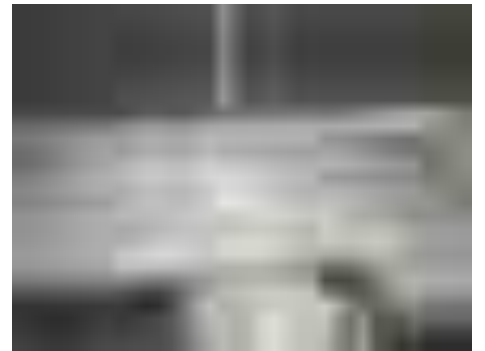

3. Using a Sawzall, cut off wheel or similar, Remove/cut the lower front cross member as shown with the yellow lines, front and back both sides.

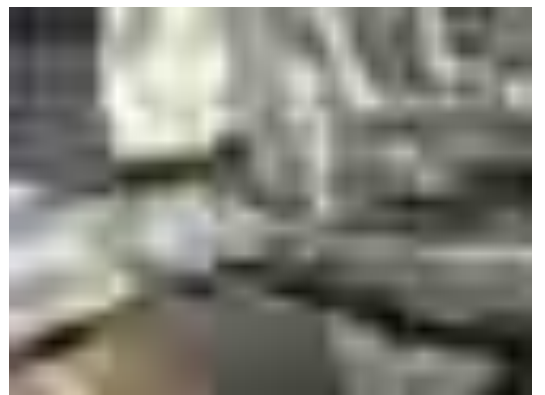

4. If a winch is to be installed. Follow the directions that came with your winch and mount to the inner 4 bolt pattern on the inside of the ¼ Pounder. The EVO MFG Quarter Pounder bumper will accept center mount winches as well as offset winches. For offset winches install the included winch fairlead jog plate on the passenger side. For center mount winches install the winch fairlead jog plate on the driver side.



5. At this time, install winch fairlead to ¼ Pounder: If applicable.

**Follow this procedure for FAIRLEAD ADJUSTMENT using the included EVO Fairlead JOG PLATE.**

**Mount EVO Fairlead Jog Plate on passenger side for Offset Winch**



**Mount EVO Fairlead Jog Plate on driver side for Centered Winch**



6. Verify that the supplied ½" bolts will insert through all the 8 factory holes in your JK's frame. If not, drill the holes that do not with a ½" drill.
7. Using the supplied hardware (2.0" without D-Rings, 2.5" with D-rings all with washers) install through the upper right and left holes of both sides (4 Bolts total). If you are using the EVO D-Rings, These should be mounted at this time on the outer face of the bumper.
8. On the inside face of the ¼ Pounder, install 2 spacer plates per side on the inside mounting face of the ¼ Pounder on the inserted bolts.
9. Install ¼ Pounder with spacer plates to factory frame.
10. Install supplied washers and nuts and 4 remaining lower bolts.
11. Torque all nuts to 80 lb/ft .



### **RUBICON Electronic SwayBar Mount Relocation Instructions:**

1. Remove bolt from the front mount of the swaybar motor. (long bolt that goes through the rubber isolator.
2. The motor will now freely rotate on the axis of the swaybar.
3. Rotate the swaybar motor rearward as much as possible.
4. With a ½" diameter drill mark off ½" from tip down on the drill with tape.
5. In the new mounting hole, drill from the passenger side toward the center of the vehicle ½" deep (up to tape mark) into new mounting hole. **DO NOT DRILL MORE THAN ½"**. You may need to loosen the two bolts on the passenger side frame rail that holds the swaybar to the frame to get your drill to drill straight into the new mounting hole.
6. Using the same bolt removed earlier install through the factory rubber isolator and into the newly drilled hole.

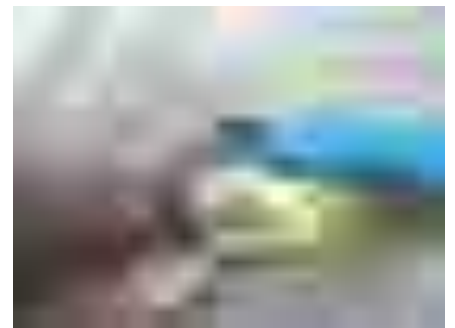



**EVO-1113B**

**EVO MFG JK Front Shock Relocation Kit**



- 1 EVO-11092B PASS LWR B/O C/O MOUNT
- 1 EVO-11092DB DRVR LWR B/O C/O MOUNT
- 1 EVO-770046 HARDWARE PACK



1. Remove lower shock bolt and remove shock out of factory bracket.

2. Turn the steering wheel to provide access to drill on the side of the factory coil spring perch.

3. Enlarge the existing hole on the side of the factory coil spring perch to  $11/32''$  .

4. Enlarge reward hole on the underside of factory shock mount to  $7/16''$  .

5. **Loosely** install the EVO MFG Front shock relocation bracket (**DO NOT TIGHTEN at this point**). 2 Bolts on the underside of the factory shock mount with  $3/8''$  hardware and side bolt with  $5/16''$  hardware.

6. Install shock into EVO relocation bracket using the provided  $1/2''$  hardware and tighten shock with all other bolts loose.

7. Tighten all other bracket mounting hardware.

8. Repeat these steps for other side of the vehicle.





**EVO-1118 / EVO-1119**

**JK Quick Release Mud Flap Kit**



<b>Qty</b>	<b>Part#</b>	<b>Description</b>
2	EVO-12054B	Mud flap Frame Mount
2	EVO-12055B	Mud flap Tube Mount
2	EVO-12056B	Mud flap Mounting Plate
1	EVO-900341	Zinc-Plated Steel Pin
2	EVO-900345	Square Finishing Plug
1	EVO-600093	Highland Splash Guard
2	EVO-900353	Carriage Bolt
2	EVO-900352	Wing Nut

**NOTE: Due to the various rear bumpers being mounted on vehicle, mounting location of the EVO MFG Quick Release Mud flap Bracket may require modification and/or relocation. If a custom location is determined to be needed on your application the EVO quick connect frame mount can be relocated to an alternative location by using 3/8" or similar self tapping screws which you can purchase at your local hardware store or welding bracket to desired location.**

**NOTE: Pinch seam corner may require slight trimming depending on where mud flap is mounted.**

1. **\*\*\* OPTIONAL \*\*\*** Included with your kit are two Ribbed Neck Carriage Bolts as well as two Wing Nuts. These are included for those customers looking for a more rigid mounting option of the mud flap tube. If you choose this option follow these steps, otherwise if the locking pins are preferred start at step 3.



2. Insert one of the carriage bolts into the bottom side of the EVO Mud flap Frame Mount as shown in the photo. Using a deep socket, around 3/8" or 10 mm works well place it over the threaded end of the carriage bolt. Place them into a vice and begin to press the carriage bolt into the mud flap frame mount. When pressing in vice, align bolt straight with hole. Press/vice bolt into hole making sure bolt stays as straight as possible while inserting. Repeat steps for the other mud flap frame mount.



3. Locate and remove the two factory bolts located on the rear of the frame. ( see photo )



4. Place the EVO Mud flap Frame Mount bracket on frame and reinstall factory bolts (as shown in photo). Repeat on other side of vehicle. Mounting bracket is slotted front to back, sliding towards the rear of vehicle will require pinch seam corner trimming.



5. Slide the EVO Mud Flap Tube on to your installed EVO mud flap frame bracket.



6. Splash guards have 4 grooves that require the thin rubber to be punctured for hardware to install. Puncture these holes out at this time.



7. Holding one of your mud flaps up to the EVO mud flap tube mark the holes on the EVO mud flap tube that best suit your tire coverage needs.

Note: The EVO mud flap tube is predrilled for widths of 16", 17", and 18"s. Excess tube length can be cut off if preferred and plugged with the supplied finishing plugs. We recommend visually checking tire coverage prior to cutting the EVO mud flap tube.

8. Remove EVO mud flap tube from EVO mud flap frame bracket.
9. Assemble the EVO Mud flap tube, EVO Mounting Plate, and Splash Guards with the supplied hardware into your previously marked holes. The rubber splash guard should be sandwiched between the EVO mud flap tube and EVO mounting plate. If you have not already done so install the finishing plugs on the mud flap tubes. Keep in mind to assemble them so you'll have a driver and passenger side.
10. Install EVO mud flaps on to the EVO mud flap frame mount.
11. Insert included locking pins (or install wing nuts if you chose that option).





## EVO-1120B EVO MFG JEEP JK/JKU HiLift Jack Tailgate Mount



PART#	DESCRIPTION	QTY
EVO-12052B	HiLift Mount	1
EVO-12053B	HiLift Upper Mount Bracket	1
EVO-900342	Aluminum Knob	1
EVO-20035	HiLift Spacer JK	2
EVO-770048	Hardware Pack	1
EVO-900343	M8 1.25 50MM Zinc	2
EVO-900344	M8 Washer Zinc	2
EVO-900347	Carriage Bolt 3/8-16 1.25 Long	1
EVO-900350	3/8" Lock Washer	1
EVO-900351	3/8" Flat Washer	1
EVO-900352	Zinc Alloy Locking Wing Nut	1
EVO-900354	Zinc Platted Ribbed Neck Carriage Bolt	1
EVO-900355	Chrome Plated Unthreaded Spacer	1

**NOTE: Installation of EVO HiLift Jack Tailgate Mount in Combination with EVO Tire Carrier will slightly limit the rear door from fully opening. Jack must be in full down position to clear tail light when tailgate door is opened. Recommended for 48" or smaller jacks, top of jack will protrude above roof line. Jack handle keepers are recommended; jacks are inherently loose and rattle. Use of zip ties and/or bungee cords to tension the jack and handle will help to quite them down.**

1. Remove factory rear tailgate plastic hinge bracket covers. Note that the top and bottom covers are slightly different in length.
2. Leaving the tailgate shut remove the two factory hinge bracket bolts on the tailgate that are closest to the right seam of the tailgate.



3. Next measure 6 7/8" from the side that was closest to the spare tire mount and mark the center point on the OE plastic hinge bracket covers as shown in photo. Note that one of the plastic hinge bracket covers is slightly longer than the other, still measure both to the recommended 6 7/8".



4. Drill each of the OE plastic hinge bracket covers with a 5/8" drill bit or larger on your previously marked 6 7/8" measurement. Note that these holes can be made in various ways but drilling is the simplest method.
5. Re Install factory plastic hinge bracket covers. Top and bottom covers are unique.



6. Insert one of the supplied spacers into each of the previously drilled holes in the OE plastic hinge bracket covers.
7. Using the 2 supplied M8 1.25 50mm bolts and washers install the EVO MFG HiLift Jack Tailgate Mount to the tailgate.

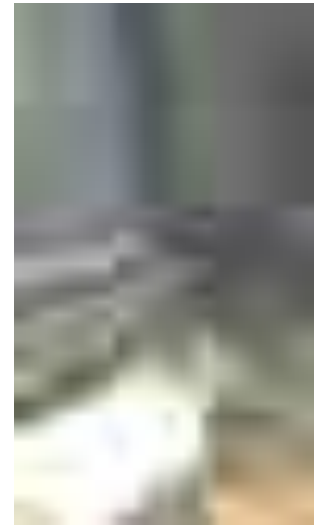

8. Using the supplied hardware bag install the EVO HiLift Upper Mount Bracket in the two left side holes as shown in the photos. Note do not tighten these bolts completely. You will tighten these down securely in step 11.

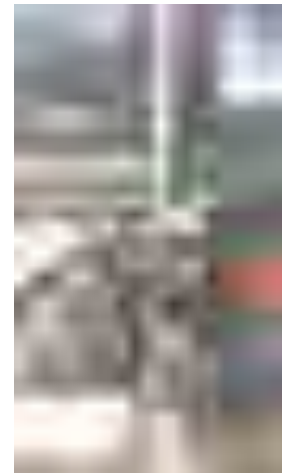
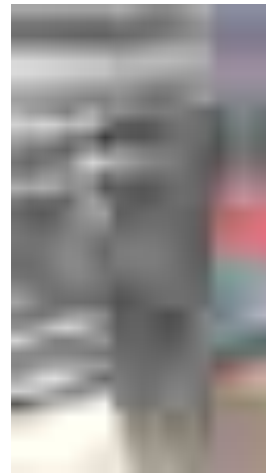

9. EVO MFG recommends drilling a 1/4" hole in the foot of your jack as shown in the photo. This hole will allow you to secure your jack with the supplied square neck carriage bolt and wing nut.

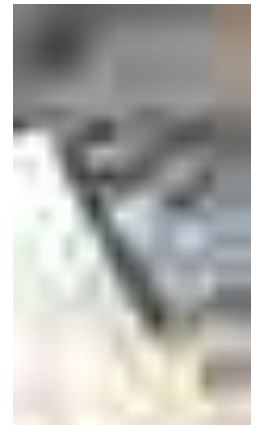
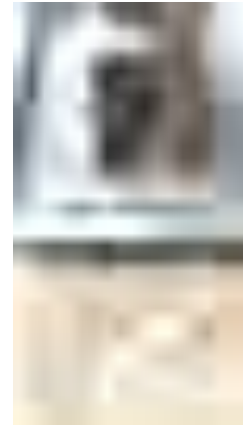

10. Install your HiLift Jack into the EVO MFG HiLift Jack Tailgate Mount.
11. Using the supplied carriage bolt, lock washer, flat washer, chrome spacer, and aluminum knob secure your HiLift Jack to the EVO MFG HiLift Jack Upper Mount Bracket.
12. Once your HiLift Jack has been secured to the EVO MFG HiLift Jack Upper Mount Bracket you can tighten down the two Upper Mount Brackets to the EVO MFG HiLift Jack Tailgate Mount.

**PERIODICALLY CHECK TIGHTNESS OF ALUMINUM KNOB.**





## **EVO-1121B 2007+ Jeep JK Evap Skid**



Part#	Description	Qty
EVO-12057B	Evap Main Skid	1
EVO-12058B	Evap Skid Rear Mount	1
EVO-770048	EVO Evap Hardware Pack	1

**Installation photos shown are on a 2012 + Jeep Wrangler JK, for those installing the EVO Evap Skid on a 07-11 Jeep JK follow the same install procedures.**

### **NOTES PLEASE READ BEFORE INSTALL**

**Keep All Mounting Bolts loose until all bolts are installed into place. Then tighten all bolts. Throughout the install there is no need to remove any of the factory hoses or factory evap mounting bracket. You will only be required to remove the factory bracket from the crossmembers.**

1. Loosen the two factory front evap skid bolts so that about  $\frac{1}{4}$ " thread are showing.



2. Loosen and remove the rear factory evap skid bolt completely.



3. Loosely install the EVO-12058B Evap Skid Rear Mount Plate using the rear factory evap skid bolt , the rear mount plate should be installed so that the plate is sandwiched between the crossmember and factory evap bracket, leaving yourself a few threads still showing.



4. Remove the two factory front evap skid bolts you previously loosened in step #1. Note the factory evap skid bracket will now be supported by the rear bolt only. You are now ready to install EVO-12057B Evap Main Skid Plate. Start by placing the front lip of the factory evap skid under the front edge of the EVO Evap Main Skid. Once you have done this the rear of the factory evap skid can be nestled into the rear of the EVO Evap Main skid.



5. Loosely secure the front of the EVO Evap Main Skid with the two factory front evap bolts, leaving a few threads showing.



6. Install the supplied hardware tightly securing the EVO evap main skid to the EVO evap rear mount plate.

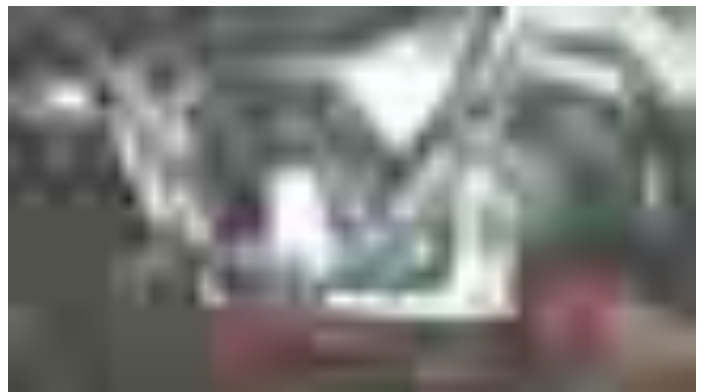
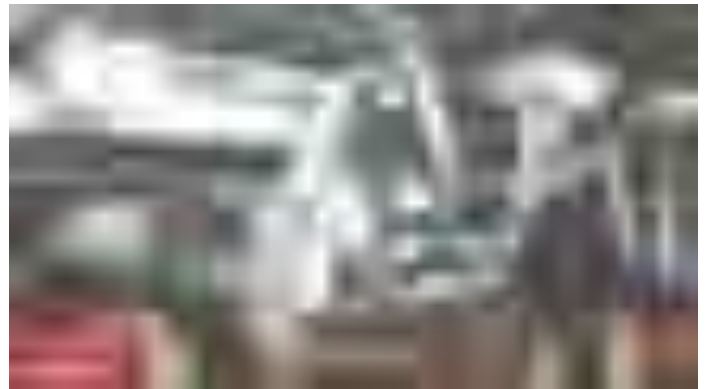

7. Tightly secure the two factory front evap bolts and the one factory rear evap bolt.

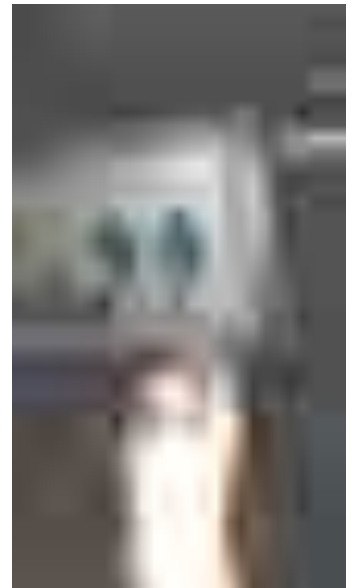



## EVO-1125B

### A Pillar Light Mount Pair, JK



Part#	Description	Qty
EVO-12064B	Passenger A Pillar Bracket	1
EVO-12065B	Driver A Pillar Bracket	1
EVO-900348	Nylon Flat Washer 5/16"	4

1. Remove the two factory T30 Torx bolts from the A Pillar.
2. Place one washer in each of the four A Pillar indentions.
3. Place the EVO A Pillar Light Mount up to the vehicle A Pillar with the Laser Cut O facing the outer side of the vehicle.
4. Reinstall the Factory T30 Torx bolts and tighten snug ( **DO NOT OVERTIGHTEN** ).
5. Repeat steps on opposite side of vehicle.



## EVO-1130

### EVO MFG Pro Series JK Front Bumper



PART#	DESCRIPTION	QTY
EVO-12071	EVO Pro Series Bumper w/ Hoop	1
EVO-12072	EVO Pro Series Bumper Winch Plate	1
EVO-12075	EVO Pro Series Bumper Winch Plate, Nut Plate	2
EVO-12076	EVO Pro Series Bumper Winch Mount Spacer	2
EVO-12077	EVO Pro Series Bumper Winch Jog Plate	1
EVO-900216	SAE Washer ½ Thru Hardend Zinc	10
EVO-900223	Stover Lock Nut ½-20 GrC Zinc	8
EVO-770045	EVO Bumper Jog Plate Hardware Pack	1
EVO-900038	HHCS ½-20 x1.00 Gr8 Zinc	2

**NOTE : 2012 and up Jeep JK's require a EVO-1096 JK Vacuum Pump Relocation kit. A 17/32" drill bit is recommended to complete installation. ½" can be substituted but gives little clearance with bumper bolt installation.**

**1.** Remove factory air dam; there are two tabs on the backside that are connected to the OE crash bar with plastic grommets. We have found that a flat head screwdriver works best to pry the grommets out. There are also a few plastic grommets near the front lip of the air dam on the front side of the vehicle that will need to be removed.



**2.** Remove factory bumper top fascia section that sits between the grill and bumper and is held in place by two plastic grommets which are slotted for a screwdriver. Unscrew the two grommets and pop off the top section fascia. If you are having troubles unscrewing the two grommets you can place a flathead screwdriver between the screw of the grommet and the grommet pry the grommet screw loose. Once the screw is removed the grommet will easily lift from the frame.

**3.** Remove factory bumper with an 18mm socket, there are 8 nuts total that will need to be removed.



**4.** (2012 and up Jeep JK's) Remove the two bolts that hold the factory vacuum pump.

**5.** If your vehicle is equip with fog lights disconnect the wiring harness by depressing the tab on the plug and pulling the plug out of the back of the fog light.

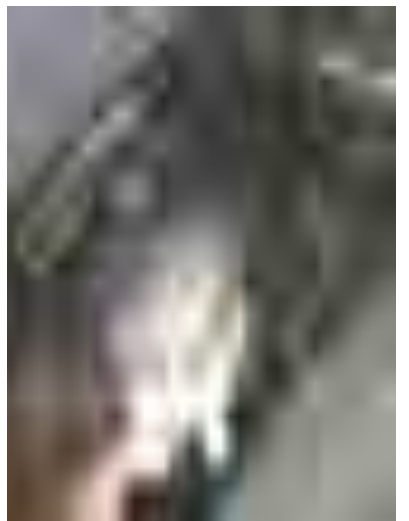

6. On the inside of the factory bumper the wire harness is attached to the bumper and frame with several grommets, remove them so that the bumper may be removed from the vehicle.



7. Carefully remove the factory bumper from the vehicle.

8. **NOTE: 2012+ Jeep JK's install your Aftermarket JK vacuum pump relocation kit at this time.**

9. Install EVO Pro Series Winch Plate. Slide the EVO winch plate in between the factory frame rails as shown. Angle the winch plate as you slip it into place and rotate the mount as needed.



**10.** Using the included winch mount spacers and winch mount nut plates install the EVO winch mount plate to the factory frame rails. The winch plate spacer should be positioned in-between the EVO winch plate and factory frame rail. **Depending on customer clearance of factory vacuum pump bracket, a spacer may or not be needed on the driver side.** The EVO winch mount nut plate should be installed in the pocket along the factory frame rail. Do not tighten at this time



**11.** Using a 17/32" Drill bit drill out the driver side upper outer side frame horn mount hole.





12. Install EVO Pro Series Front Bumper on to vehicle, 8 capture bolts on bumper go through the frame, then through the EVO winch plate, then securing it to the factory front frame horns with the included  $\frac{1}{2}$ " washers and  $\frac{1}{2}$ "-20 stover lock nuts. Torque to 85 ft/lbs.
13. Tighten rear winch mount bolts to nut plate 85 ft/lbs.

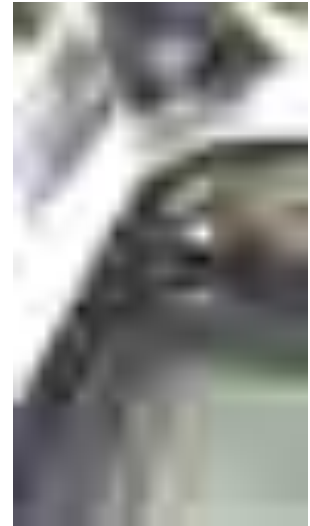

**Winch Mounting Notes:**

\* Mount your winch to EVO winch mount by installing the two rear winch bolts loosely through the EVO winch plate into your winch. (Do not tighten them at this time). Follow winch mfg instructions on how to install winch. Keep the below notes in mind when doing so.

\* If you have purchased the EVO MFG Pro Series Bumper Skid plate follow the instructions included with your skid plate at this point.

\* If you have not purchased the optional EVO MFG Pro Series Skid Plate Install the front two winch mounting bolts through the EVO winch plate and into your winch.

\* Tighten all winch mounting bolts to winch manufacturer's instructions.

Install EVO Fairlead Jog Plate on passenger side for  
Offset winches



Install EVO Fairlead Jog Plate on driver side for  
Centered Winches



**EVO Jog Plate Notes:**

\*The EVO MFG Pro Series Front bumper is designed to fit both center mount and offset mount winches. Included is the EVO jog plate and jog plate hardware pack.

\*If you are installing an offset winch for example a Warn Powerplant, install the EVO jog plate on the passenger side of bumper.

\*If you are installing a center mount winch such as the Warn Zeon, install the EVO jog plate on the driver side of bumper.



## EVO-1131

### EVO PRO Series Front Bumper Skid



PART#	DESCRIPTION	QTY
EVO-12073	Pro Series Front Bumper Lower Skid	1
EVO-900022	3/8-24 x 1.00 Gr8 Zinc	2
EVO-900214	SAE Washer 3/8-24	4
EVO-900221	Stover Lock Nut 3/8-24 GrC Zinc	2

**NOTE:** If you are installing the EVO PRO Series Front Bumper Skid plate and already have a winch installed on your EVO PRO Series Front Bumper you will need to loosen the two rear winch bolts and remove the two front winch bolts prior to installing this skid.

### **2011 and newer Jeep JK's**

The factory front cross member requires minor trimming near the frame for proper installation (see photo). This trimming is required on both driver and passenger sides of the cross member. Cut the small lip that hangs below the cross member off on all sides flush with cross member. Grind all edges flush and smooth. Painting of unfinished metal surfaces prior to install is recommended.



- 1. Using the supplied hardware and the two front winch bolts you previously removed loosely install the EVO PRO Series Front Bumper Skid plate to the EVO PRO Series Front Bumper.**
- 2. Once all your mounting bolts are in place, line up the EVO skid plate with the bumper on all edges to ensure a clean fit and tighten all bolts to spec.**
- 3. Tighten rear winch bolts**
- 4. On the lower edge of the EVO PRO Series Front Bumper Skid plate there are two mounting holes. Using a drill and 3/8" drill bit drill through the two existing mounting holes in the skid and through the factory cross member.**
- 5. Install the supplied hardware and tighten to 37 ft/lbs.**





**EVO-1132**

**EVO MFG Pro Series JK Rear Bumper**



<b>PART#</b>	<b>DESCRIPTION</b>	<b>QTY</b>
EVO-12070	EVO PRO SERIES REAR BUMPER	1
EVO-11053B	PASS SIDE FRAME PLATE	1
EVO-11054B	DRVR SIDE FRAME PLATE	1
EVO-770052	HARDWARE PACK	1

1. Carefully remove factory rear bumper from vehicle. Removing the two bolts along the side of the rear frame rail as well as the bolts on the rear crossmember. The two smaller bolts from each side will be reused later in the install process. Some rear bumpers will require the removal of the four trailer hitch bolts if so in order to reuse trailer hitch you will need to supply locking nuts for these bolts. Torque to factory specifications.

2. Factory trailer hitch bolts vary between models and optioned equipment. If bolts are too long they must be shortened or replaced. To shorten, with nuts installed and torqued to factory specs. Either grind down to given enough clearance with bumper or follow these procedures to score and shear excess. With cut off wheel, Sawzall or similar. Score bolt excess half way through diameter. Tap end with hammer to shear excess. Clean with grinder.

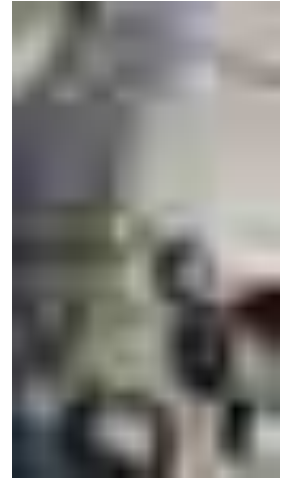
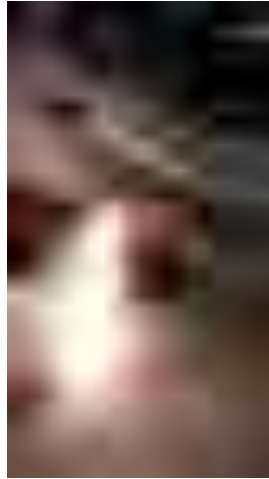

3. With a helper carefully insert the EVO MFG Pro Series Rear Bumper into the openings of the rear frame rails.

4. Once you have the EVO MFG Pro Series Rear Bumper inserted into the rear frame rails line up the included EVO rear frame rail plates to the corresponding side. The two smaller holes will rest on the side closest to the front of the vehicle. See photos for example

5. Loosely install the two included 9/16" bolts with washers on each side of the vehicle through the EVO rear frame plates and thread into bumper mounts. DO NOT TIGHTEN

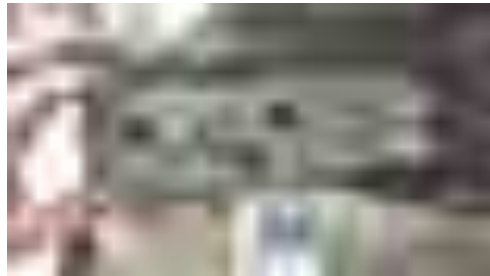

6. Using a clamp, clamp the underside bottom of the EVO MFG Pro Series Rear Bumper to the factory rear crossmember. Be sure to verify that the bumper is lined up to your satisfaction.
7. Using a center punch or marker, mark through the circular mounting holes in the bottom of the EVO MFG Pro Series Rear Bumper and on the rear crossmember as centered in the hole as possible.
8. Carefully remove your clamp and the 9/16" hardware holding the EVO MFG Pro Series Rear Bumper to the vehicle. Remove bumper at this time.
9. Using a 7/16" drill the previously marked locations on the rear crossmember.



10. Install supplied nut clips into the rear crossmember through the holes to the outside of the previously drilled mounting holes. If necessary a hammer may be used to assist in inserting the nut clips. Align nut clip threaded hole with previously drilled holes.

11. With a helper carefully insert the EVO MFG Pro Series Rear Bumper into the rear frame rail openings.

12. Once you have the EVO MFG Pro Series Rear Bumper inserted into the rear frame rails line up the included EVO rear frame rail plates and loosely secure them with the included 9/16" bolts and washers.

13. Loosely install the two small factory frame rail bolts through the EVO frame rail plates.

14. Install the included 3/8" Hex Cap screws through the bottom side of the EVO MFG Pro Series Rear Bumper into the previously installed nut clips.

15. At this time torque all bolts.

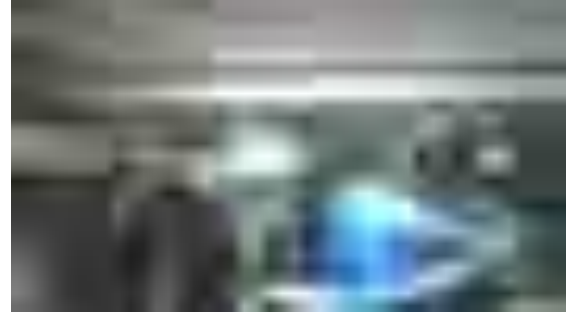

### **Optional EVO MFG License plate relocation bracket installation:**

1. Remove spare tire from factory spare tire holder.
2. Install the EVO MFG License plate relocation base bracket on to the factory spare tire holder studs as shown in photo.
3. Reinstall spare tire onto the spare tire holder and tighten to factory specs.
4. Install EVO MFG license plate relocation plate bracket on to the EVO MFG License plate base bracket to desired depth using the included hardware.

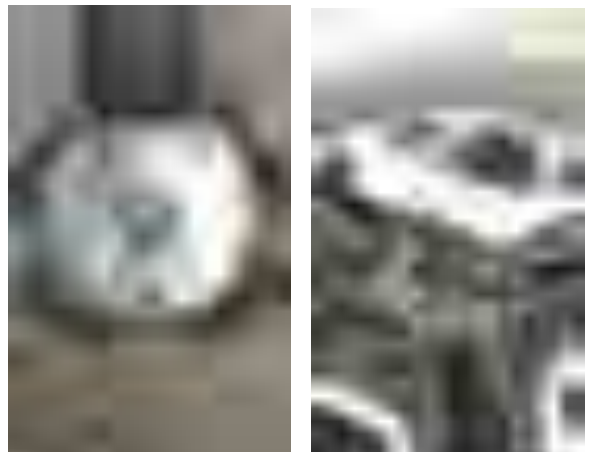

### **Optional Items ( Sold Separately )**

- ORO light plate w/ 6ft harness #LD-PL6 ( Third Brake light and License plate with 6ft wiring harness )
- Mopar License Plate delete #MOPAR-55397112AA( Plastic Delete plug )

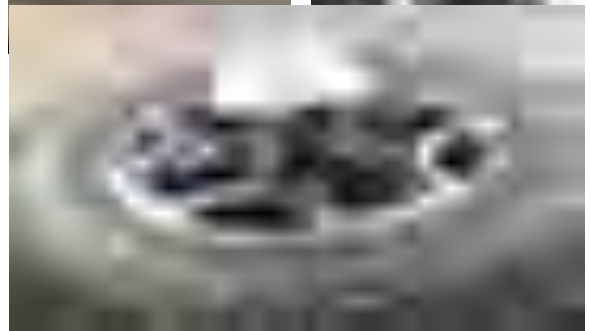



**EVO-1137-30 / EVO-1137-44**

## **EVO MFG ProTek Front Axle Truss JK**

<b>Description</b>	<b>Qty</b>
JK Truss Passenger Long Section	1
JK Truss Driver Section	1
JK Truss Passenger Short Section	1
JK Truss Forward Bridge Section	1
JK Truss Top Bridge Section	1
JK Truss Passenger Long Backbone	1
JK Truss Passenger Short Backbone	1
JK Truss Main TBar Bracket	1
JK Truss Rear TBar Bracket	1

**NOTES: Recommended weld with axle suspended not under load of vehicle.**

**Only weld to cast if you are experienced in the process, welding to cast is not required.**

**1-1/2 inch minimum bump stop extensions required for truss, 2" with bridge installation.**

**Installer do a full inspection for clearance on all surrounding components prior to welding.**

**Some grinding / sanding may be required to achieve your desired fitment.**

**Truss should be welded alternating sides from ends to middle. Definitely not welded while under vehicle load and recommended to be welded while slightly preloaded/tensioned in opposite direction.**

1. Place EVO Passenger side long and short truss sections with backbones on top of axle as shown in illustration. Ensure the truss and backbone are seated to your axle and in tab grooves on top of truss sections. **NOTE:** Sand all contact areas on axle clear of any paint in areas to be welded.



2. Tack weld the EVO backbones to the factory upper control arm mount through the access cut outs on the truss sections as shown in illustration.



3. Remove EVO Passenger side Short and Long Truss sections from axle. Weld EVO backbones to the factory upper control arm mounts as show in illustration. Alternate welding front side to back side, as well as opposite sides of the backbone.





4. Tack backbones outer most ends prior to fully welding. Weld EVO backbones to axle tubes. Alternate front to back, side to side as shown in illustration numbering. Numbers designate order of welds.



5. Place EVO Short and Long passenger side truss sections back on axle. Tabs on backbones should line up with slots in EVO truss sections. Ensure truss sections seat in place and adjust as needed. Some taps with a hammer may be necessary to align. Tack weld to the axle in multiple locations at the ends of all brackets. Once you are satisfied with the fit weld the EVO Short and Long passenger truss sections. Be certain to alternate sides from ends to middle as shown in illustrations.



6. Weld Backbone tab slots as shown in illustration.



7. Place EVO driver side truss section on axle as shown in illustration and weld to spring perch and axle tube.



8. Place EVO Bridge and Bridge Top section on axle as shown in illustration. Verify acceptable fitment and tack weld bridge to truss in multiple locations prior to fully welding.



9. Weld contact areas of front bridge to truss sections. Weld top bridge tabs to bridge slots as shown in illustration.



10. Weld the EVO bridge top section to the EVO front bridge section.

**( DO NOT WELD ONE CONTINUOUS WELD, alternate end to end in 2" weld sections )**

11. Weld EVO bridge to EVO passenger and driver side truss sections. Darker lines in illustration are for reference only. Do not weld as one continuous weld.



**Optional install with Draglink Flip Kits, verify draglink draglink and trackbar are parallel adjust accordingly.**

12. Insert inner and outer trackbar bracket around factory trackbar mount. Loosely install trackbar into new higher location.
13. Tack all bracketry in multiple locations.
14. After verification of trackbar and draglink alignment, and a full interference check, weld all bracketry connection to all axle components.



15. Remove Trackbar, Paint all exposed metal.
16. Reinstall trackbar and torque to factory specifications.

Passenger side middle hole can be used for steering stabilizer relocation, spacers between bracket and stabilizer may be required ( not included ).



## **EVO-1137-30 / EVO-1137-44**

### **EVO MFG ProTek Front Axle Truss JK**



<b>Description</b>	<b>Qty</b>
JK Truss Passenger Long Section	<b>1</b>
JK Truss Driver Section	<b>1</b>
JK Truss Passenger Short Section	<b>1</b>
JK Truss Forward Bridge Section	<b>1</b>
JK Truss Top Bridge Section	<b>1</b>
JK Truss Passenger Long Backbone	<b>1</b>
JK Truss Passenger Short Backbone	<b>1</b>
JK Truss Main TBar Bracket	<b>1</b>
JK Truss Rear TBar Bracket	<b>1</b>

**NOTES: Recommended weld with axle suspended not under load of vehicle.**

**Only weld to cast if you are experienced in the process, welding to cast is not required.**

**1-1/2 inch minimum bump stop extensions required for truss, 2" with bridge installation.**

**Installer do a full inspection for clearance on all surrounding components prior to welding.**

**Some grinding / sanding may be required to achieve your desired fitment.**

**Truss should be welded alternating sides from ends to middle. Definitely not welded while under vehicle load and recommended to be welded while slightly preloaded/tensioned in opposite direction.**

1. Place EVO Passenger side long and short truss sections with backbones on top of axle as shown in illustration. Ensure the truss and backbone are seated to your axle and in tab grooves on top of truss sections. **NOTE:** Sand all contact areas on axle clear of any paint in areas to be welded.



2. Tack weld the EVO backbones to the factory upper control arm mount through the access cut outs on the truss sections as shown in illustration.



3. Remove EVO Passenger side Short and Long Truss sections from axle. Weld EVO backbones to the factory upper control arm mounts as show in illustration. Alternate welding front side to back side, as well as opposite sides of the backbone.



4. Tack backbones outer most ends prior to fully welding. Weld EVO backbones to axle tubes. Alternate front to back, side to side as shown in illustration numbering. Numbers designate order of welds.



5. Place EVO Short and Long passenger side truss sections back on axle. Tabs on backbones should line up with slots in EVO truss sections. Ensure truss sections seat in place and adjust as needed. Some taps with a hammer may be necessary to align. Tack weld to the axle in multiple locations at the ends of all brackets. Once you are satisfied with the fit weld the EVO Short and Long passenger truss sections. Be certain to alternate sides from ends to middle as shown in illustrations.



6. Weld Backbone tab slots as shown in illustration.



7. Place EVO driver side truss section on axle as shown in illustration and weld to spring perch and axle tube.



8. Place EVO Bridge and Bridge Top section on axle as shown in illustration. Verify acceptable fitment and tack weld bridge to truss in multiple locations prior to fully welding.



9. Weld contact areas of front bridge to truss sections. Weld top bridge tabs to bridge slots as shown in illustration.



10. Weld the EVO bridge top section to the EVO front bridge section.

**( DO NOT WELD ONE CONTINUOUS WELD, alternate end to end in 2" weld sections )**

11. Weld EVO bridge to EVO passenger and driver side truss sections. Darker lines in illustration are for reference only. Do not weld as one continuous weld.



**Optional install with Draglink Flip Kits, verify draglink draglink and trackbar are parallel adjust accordingly.**

12. Insert inner and outer trackbar bracket around factory trackbar mount. Loosely install trackbar into new higher location.
13. Tack all bracketry in multiple locations.
14. After verification of trackbar and draglink alignment, and a full interference check, weld all bracketry connection to all axle components.



15. Remove Trackbar, Paint all exposed metal.
16. Reinstall trackbar and torque to factory specifications.

Passenger side middle hole can be used for steering stabilizer relocation, spacers between bracket and stabilizer may be required ( not included ).





**EVO-1138**  
**EVO MFG Rear Axle Truss**



PART#	DESCRIPTION	QTY
EVO-1138	EVO Rear Axle Truss	1

**NOTES: Recommended weld with axle suspended not under load of vehicle.  
Only weld to cast if you are experienced in the process, welding to cast is not required.  
1 inch minimum bump stop extensions required to clear factory exhaust.**

**Installer do a full inspection for clearance on all surrounding components prior to welding.  
Some grinding / sanding may be required to achieve your desired fitment.**

1. Remove axle breather tube from axle fitting.
2. Place EVO MFG Rear Axle truss on top of your rear axle, be sure to verify breather tube hole is aligned properly with breather fitting on axle tube.
3. Align Truss square with axle. May require slight sanding / grinding to achieve your desired fitment.



4. Verify OE wiring connectors for rear locker are clear and removable.
5. Tack truss to axle tubes as illustrated in photos by circles on both driver and passenger side front and rear as well as outer ends of truss.



6. Due to aftermarket components variances, verify surrounding component clearances around truss. Trackbar, exhaust, wiring, etc, through cycle up and down.
7. Weld all contact points between truss and axle as illustrated in photos by bold lines. As previously mentioned it is not necessary to weld to casting. If welding to the casting is desire please be sure that the installer is experienced with the process.

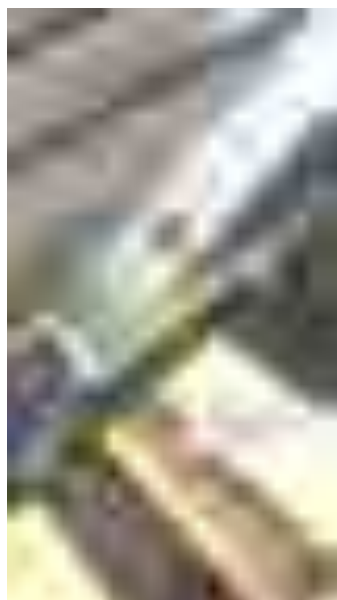

8. Reinstall axle breather tube to fitting.
9. Paint or coat truss.



**EVO-1144, EVO-1144B**

**EVO MFG 2007-2011 HD ProTek Transmission Crossmember**



**EVO-1145, EVO-1145B**

**EVO MFG 2012 + HD ProTek Transmission Crossmember**



**Note:**

**Powdercoated crossmembers are coated on the exterior only.**

1. Support vehicle transmission with a jack or similar. Only use enough pressure to support the transmission.
2. Remove the two bolts connecting the factory gas tank skid to the transmission crossmember.
3. Completely remove the factory transercase skid plate.
4. If your vehicle came equip with a skid plate forward of the transercase completely remove it.
5. Remove the bolts securing the factory transmission crossmember.

6. Remove the factory transmission crossmember from the vehicle, you may find it easiest to drop the driver side down first. This will allow you to remove the passenger side out from the factory pocket and around the front side of the factory gas tank skid.



7. Insert the EVO HD transmission crossmember into place on the vehicle, sliding the passenger side up and in position along the factory frame rail.



8. Secure the EVO HD transmission crossmember in place starting with the two bolts on each end and working your way towards the middle of the transmission crossmember.



9. Secure factory gas tank skid to the EVO HD Protek transmission crossmember.
10. Install previously removed factory skid plates back on to vehicle.





## EVO-1148AL/EVO-1149AL

### EVO Hood Breach



#### Bill of Materials

EVO-1148AL EVO Hood Breach Single Sprayer		
Part number	Description	Quantity
EVO-12135AL	EVO Hood Breach Single Sprayer	1
EVO-12136AL	EVO Hood Breach Overlay Single Sprayer	1
EVO- 770057	EVO Hood Breach Hardware Pack	1
EVO-1149AL EVO Hood Breach Dual Sprayer		
Part number	Description	Quantity
EVO-12135AL	EVO Hood Breach Dual Sprayer	1
EVO-12136AL	EVO Hood Breach Overlay Dual Sprayer	1
EVO- 770057	EVO Hood Breach Hardware Pack	1

**Note: This product requires drilling and cutting of painted body sheet metal. When cutting the openings below the hood Breach to allow better ventilation to the engine compartment and potential heat reduction, openings are created where water and debris can enter. Additionally, fitting the flat Hood Breach to the curved hood can cause slight lifting**

**between bolts. If you are not comfortable with any of the above, do not proceed with install.**

**Note: While not required, colored duct tape can be applied to the hood below the "EVO" logo before final install to create a 2 toned effect if desired.**

**Note: It is recommended to remove the hood for this install**

1. On the underside of the hood, unplug the hoses connected to the windshield sprayers.
2. Remove the foam padding from the underside of the hood by pulling the clips holding it in place loose (shown below). Replace hoses from Step 1

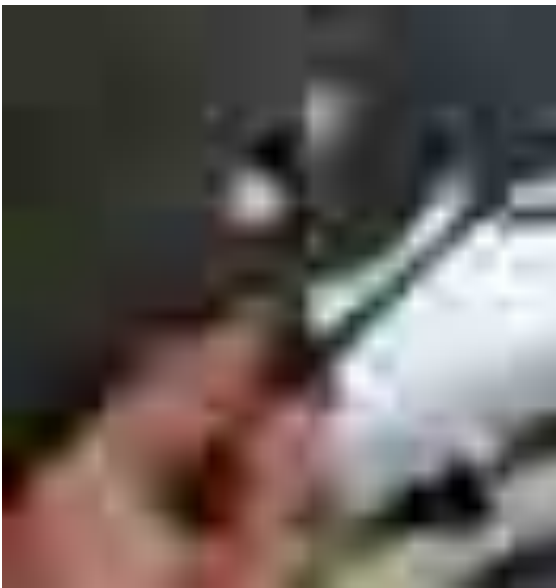

3. Remove the footman loop in the center and the 2 rubber bumpers on your hood. Squeeze the underside of the bumpers together with pliers to remove them.
4. Place the Overlay (the part without slots) over the hood. Loosely bolt the footman loop back on. Do no tighten at this time. Put the bumpers back on and align the Overlay with your hood. When you are happy with the placement, tighten the bolts of the footman loop.

5. **ONLY IF YOU ARE HAPPY WITH THE PLACEMENT**, MAKE SURE THE OVERLAY IS FLUSH WITH THE HOOD AND DOES NOT MOVE. Mark each of the 22 holes around the Overlay to drill.

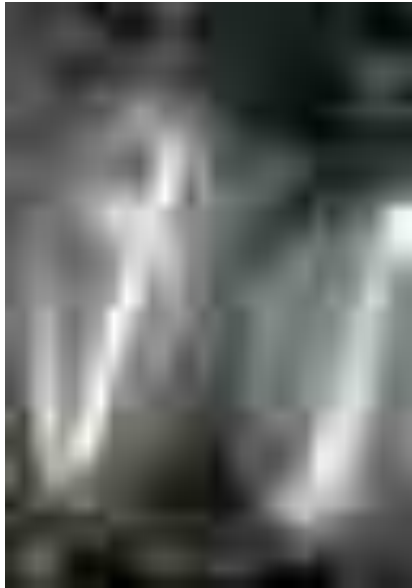

6. (OPTIONAL) Only if you are planning to cut openings into your hood, mark the openings following the outline of the Overlay.
7. Remove the Overlay by removing the footman loop and rubber stoppers.
8. Again, **ONLY IF YOU ARE HAPPY WITH THE PLACEMENT**, and you have **CHECKED YOUR MARKINGS FOR ACCURACY**, center-punch the marks and drill the holes out using a 9/32" drill bit.





**Steps 7-11 are optional. If you do not plan to cut openings, skip to step 12**

9. (OPTIONAL) WEARING SAFETY GLASSES Cut the openings out carefully following your marks. You will want to cut just outside the marks, as shown, so the hood doesn't show through. A cut-off wheel or similar tool is recommended. When cutting, be careful not to cut through the substructure, this will damage your hood. **ONLY CUT THROUGH THE TOP SURFACE SHEETMETAL, DO NOT CUT UNDERSIDE SUBSTRUCTURE.**



- 10.(OPTIONAL) The hood is attached to the substructure with foam adhesive. A gentle pull will separate the cutouts from the substructure.
- 11.(OPTIONAL) Sand the rough edges left by the cutoff wheel and scrape off residue from the foam adhesive.
- 12.(OPTIONAL) Paint the exposed edges. Start by taping off the hood with masking tape like shown, to prevent accidental overspray.
- 13.(OPTIONAL) Using paint that matches your body color, paint the exposed edges. Be sure to avoid getting paint on any part of your Jeep you don't want painted.



14. After allowing the paint to dry completely, put the Hood Breach and Overlay in place using the footman loop and rubber stoppers the same as before (Step2).
15. Secure the Hood Breach with Overlay on top using the supplied ¼" cap screws and locknuts, a 5/32" hex wrench and a 7/16" wrench. Start at the windshield and work toward the bumper, alternating sides as you tighten the screws.
16. 2 of the screws are longer than the rest, these are for the holes marked below.
17. You will also have to drill 2 larger relief holes into the substructure to allow the locknuts to fit. These are on the passenger side and are marked below. These should be drilled with a 5/8" bit. **Don't go through the hood. Only enlarge the hole in the underside substructure.**

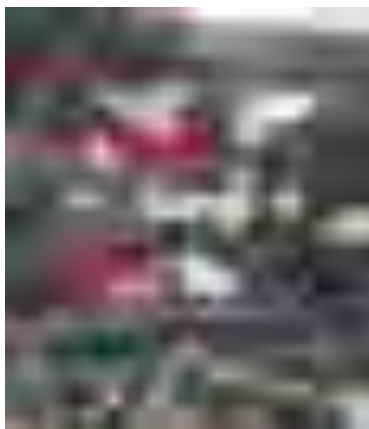
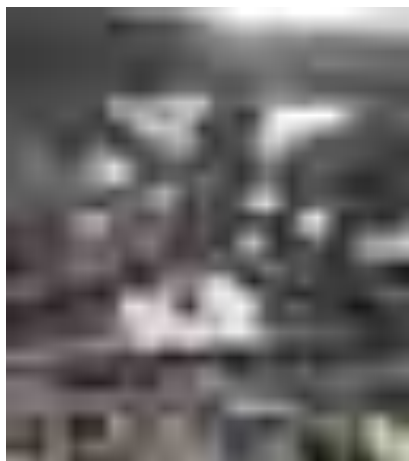



## EVO-1148AL/EVO-1149AL

### EVO Hood Breach



#### Bill of Materials

EVO-1148AL EVO Hood Breach Single Sprayer		
Part number	Description	Quantity
EVO-12135AL	EVO Hood Breach Single Sprayer	1
EVO-12136AL	EVO Hood Breach Overlay Single Sprayer	1
EVO- 770057	EVO Hood Breach Hardware Pack	1
EVO-1149AL EVO Hood Breach Dual Sprayer		
Part number	Description	Quantity
EVO-12135AL	EVO Hood Breach Dual Sprayer	1
EVO-12136AL	EVO Hood Breach Overlay Dual Sprayer	1
EVO- 770057	EVO Hood Breach Hardware Pack	1

**Note: This product requires drilling and cutting of painted body sheet metal. When cutting the openings below the hood Breach to allow better ventilation to the engine compartment and potential heat reduction, openings are created where water and debris can enter. Additionally, fitting the flat Hood Breach to the curved hood can cause slight lifting**

**between bolts. If you are not comfortable with any of the above, do not proceed with install.**

**Note: While not required, colored duct tape can be applied to the hood below the "EVO" logo before final install to create a 2 toned effect if desired.**

**Note: It is recommended to remove the hood for this install**

1. On the underside of the hood, unplug the hoses connected to the windshield sprayers.
2. Remove the foam padding from the underside of the hood by pulling the clips holding it in place loose (shown below). Replace hoses from Step 1



3. Remove the footman loop in the center and the 2 rubber bumpers on your hood. Squeeze the underside of the bumpers together with pliers to remove them.
4. Place the Overlay (the part without slots) over the hood. Loosely bolt the footman loop back on. Do no tighten at this time. Put the bumpers back on and align the Overlay with your hood. When you are happy with the placement, tighten the bolts of the footman loop.

5. **ONLY IF YOU ARE HAPPY WITH THE PLACEMENT**, MAKE SURE THE OVERLAY IS FLUSH WITH THE HOOD AND DOES NOT MOVE. Mark each of the 22 holes around the Overlay to drill.

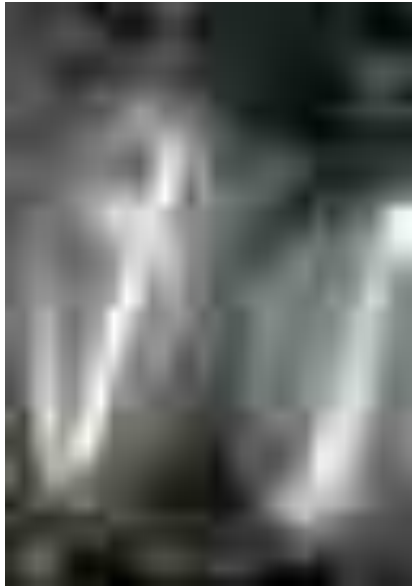

6. (OPTIONAL) Only if you are planning to cut openings into your hood, mark the openings following the outline of the Overlay.
7. Remove the Overlay by removing the footman loop and rubber stoppers.
8. Again, **ONLY IF YOU ARE HAPPY WITH THE PLACEMENT**, and you have **CHECKED YOUR MARKINGS FOR ACCURACY**, center-punch the marks and drill the holes out using a 9/32" drill bit.



**Steps 7-11 are optional. If you do not plan to cut openings, skip to step 12**

9. (OPTIONAL) WEARING SAFETY GLASSES Cut the openings out carefully following your marks. You will want to cut just outside the marks, as shown, so the hood doesn't show through. A cut-off wheel or similar tool is recommended. When cutting, be careful not to cut through the substructure, this will damage your hood. **ONLY CUT THROUGH THE TOP SURFACE SHEETMETAL, DO NOT CUT UNDERSIDE SUBSTRUCTURE.**



- 10.(OPTIONAL) The hood is attached to the substructure with foam adhesive. A gentle pull will separate the cutouts from the substructure.
- 11.(OPTIONAL) Sand the rough edges left by the cutoff wheel and scrape off residue from the foam adhesive.
- 12.(OPTIONAL) Paint the exposed edges. Start by taping off the hood with masking tape like shown, to prevent accidental overspray.
- 13.(OPTIONAL) Using paint that matches your body color, paint the exposed edges. Be sure to avoid getting paint on any part of your Jeep you don't want painted.



14. After allowing the paint to dry completely, put the Hood Breach and Overlay in place using the footman loop and rubber stoppers the same as before (Step2).
15. Secure the Hood Breach with Overlay on top using the supplied ¼" cap screws and locknuts, a 5/32" hex wrench and a 7/16" wrench. Start at the windshield and work toward the bumper, alternating sides as you tighten the screws.
16. 2 of the screws are longer than the rest, these are for the holes marked below.
17. You will also have to drill 2 larger relief holes into the substructure to allow the locknuts to fit. These are on the passenger side and are marked below. These should be drilled with a 5/8" bit. **Don't go through the hood. Only enlarge the hole in the underside substructure.**

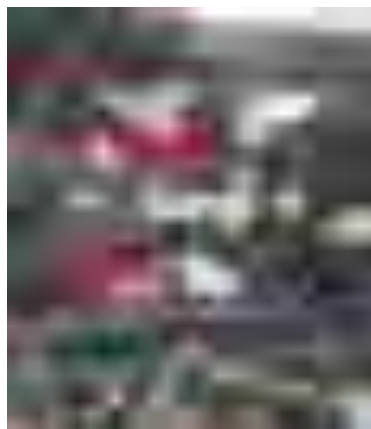
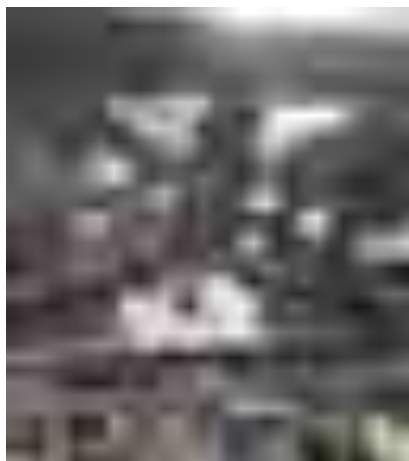



## EVO-1150-4D

### EVO Boatside Bombers



#### Bill of Materials

Part number	Description	Quantity
EVO-12100	EVO 4 Door Driver Boatside Bomber	1
EVO-12101	EVO 4 Door Passenger Boatside Bomber	1
EVO-12102	EVO Driver Boatside Rocker	1
EVO-12103	EVO Passenger Boatside Rocker	1
EVO- 770053	Boatside Bomber Hardware Pack	1

**Note: This kit requires drilling into the body of your vehicle. Make sure the**

**Boatside Rocker Panel follows the bodyline of your vehicle before**

**proceeding with install.**



You only get one shot at correct install. Before drilling, make sure you are satisfied.

**Nutsert tool / Threaded insert tool should be used for installation and can be found online at such places as Amazon, Harbor Freight, and many other tool supply companies web sites. Thread size required is ¼-20**

### **Test fit/install before paint/powdercoat**

1. If equipped, remove the rails under the rocker panel. They are held in place by 3 13 mm bolts from the bottom of the body and 6, 10mm nuts from the back underside of pinch seam.
2. With rails removed, tape off the areas to be marked and drilled (Shown Below)



3. Using an 18mm wrench, remove the bolts from the 3 body mounts on each side. Mark each bolt with the mount location that each came from.



4. Only after taping the body off to avoid scratches in the paint, clamp the Boatside Bomber Body Panels to the body. You will need to remove or lift the trim on the inside under the door to allow the clamp to reach the backside of the body sheet metal.
5. Position the Boatside Body Panels to match the body lines and the outline of the door. Only mark and drill after you are satisfied with location and alignment.



6. **When Drilling Bode Sheet Metal**, go very slow and use light pressure, the drill may have a tendency to bite in. It is recommended to start small and step up the size of the drill incrementally.
7. Only if you are satisfied with the position of the Boatside Bomber Body Panels and they are securely clamped, use a 5/16" drill bit to pilot drill all the holes into the body sheet metal. Make sure the Boatside Bomber Body Panels do not move during this process.
8. Remove the Boatside Body Panels and use a 3/8 to 25/64 drill bit to open the holes up. Drill sizes can vary so verify your fitment with the threaded inserts. They should fit snug in the drilled hole and may require a light tap.

9. The 3 holes marked below will require drilling through a second layer of sheet metal below the surface to allow the threaded inserts to fully seat.
10. Use a countersink (or larger drill bit) to remove the flared edge left around each hole on body.

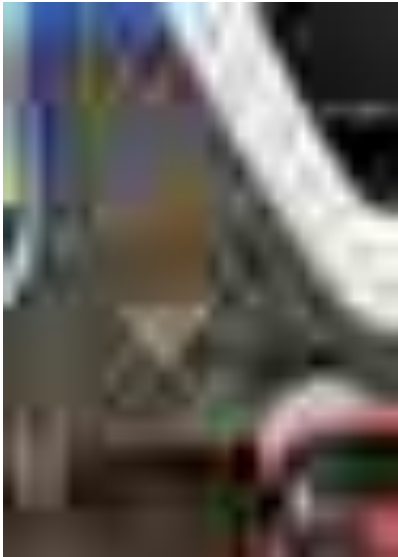

11. Use threaded insert tool to install threaded inserts/rivet nuts in all holes drilled into body
12. Place supplied clip nuts on each tab on the Boatside Bomber Body Panels as shown. Center the thread over hole and below the panel.



13. Using a 5/32" Allen wrench, install Boatside body panel by screwing the smaller supplied cap screws into the threaded inserts
14. Install Boatside Bomber Lower sections by resting them on the tabs of the already installed Body Panel and loosely threading the larger cap screws into the nut clips. Do not tighten them yet.
15. Replace the 3 body mount bolts from each side removed in step 3 to secure the Lower part of the Boatside Bombers.
16. With body mount bolts in place, use 3/16" Allen wrench to tighten the Boatside Bomber Lower to the clip nuts on the Body Panels.



17. With raw parts installed and fitting correctly, remove the Boatside Bombers and have them powder coated, or otherwise treated to prevent rust. Repeat steps 10 and 11 to reinstall.



## EVO-1150-4D

### EVO Boatside Bombers



#### Bill of Materials

Part number	Description	Quantity
EVO-12100	EVO 4 Door Driver Boatside Bomber	1
EVO-12101	EVO 4 Door Passenger Boatside Bomber	1
EVO-12102	EVO Driver Boatside Rocker	1
EVO-12103	EVO Passenger Boatside Rocker	1
EVO- 770053	Boatside Bomber Hardware Pack	1

**Note: This kit requires drilling into the body of your vehicle. Make sure the**

**Boatside Rocker Panel follows the bodyline of your vehicle before**

**proceeding with install.**

You only get one shot at correct install. Before drilling, make sure you are satisfied.

**Nutsert tool / Threaded insert tool should be used for installation and can be found online at such places as Amazon, Harbor Freight, and many other tool supply companies web sites. Thread size required is ¼-20**

### **Test fit/install before paint/powdercoat**

1. If equipped, remove the rails under the rocker panel. They are held in place by 3 13 mm bolts from the bottom of the body and 6, 10mm nuts from the back underside of pinch seam.
2. With rails removed, tape off the areas to be marked and drilled (Shown Below)



3. Using an 18mm wrench, remove the bolts from the 3 body mounts on each side. Mark each bolt with the mount location that each came from.



4. Only after taping the body off to avoid scratches in the paint, clamp the Boatside Bomber Body Panels to the body. You will need to remove or lift the trim on the inside under the door to allow the clamp to reach the backside of the body sheet metal.
5. Position the Boatside Body Panels to match the body lines and the outline of the door. Only mark and drill after you are satisfied with location and alignment.



6. **When Drilling Bode Sheet Metal**, go very slow and use light pressure, the drill may have a tendency to bite in. It is recommended to start small and step up the size of the drill incrementally.
7. Only if you are satisfied with the position of the Boatside Bomber Body Panels and they are securely clamped, use a 5/16" drill bit to pilot drill all the holes into the body sheet metal. Make sure the Boatside Bomber Body Panels do not move during this process.
8. Remove the Boatside Body Panels and use a 3/8 to 25/64 drill bit to open the holes up. Drill sizes can vary so verify your fitment with the threaded inserts. They should fit snug in the drilled hole and may require a light tap.

9. The 3 holes marked below will require drilling through a second layer of sheet metal below the surface to allow the threaded inserts to fully seat.
10. Use a countersink (or larger drill bit) to remove the flared edge left around each hole on body.

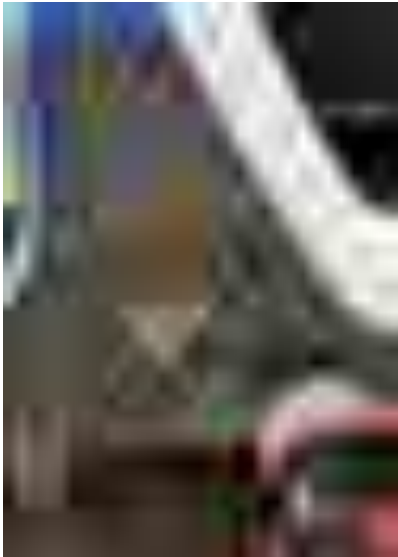

11. Use threaded insert tool to install threaded inserts/rivet nuts in all holes drilled into body
12. Place supplied clip nuts on each tab on the Boatside Bomber Body Panels as shown. Center the thread over hole and below the panel.





13. Using a 5/32" Allen wrench, install Boatside body panel by screwing the smaller supplied cap screws into the threaded inserts
14. Install Boatside Bomber Lower sections by resting them on the tabs of the already installed Body Panel and loosely threading the larger cap screws into the nut clips. Do not tighten them yet.
15. Replace the 3 body mount bolts from each side removed in step 3 to secure the Lower part of the Boatside Bombers.
16. With body mount bolts in place, use 3/16" Allen wrench to tighten the Boatside Bomber Lower to the clip nuts on the Body Panels.



17. With raw parts installed and fitting correctly, remove the Boatside Bombers and have them powder coated, or otherwise treated to prevent rust. Repeat steps 10 and 11 to reinstall.



## EVO-1152

### No Limits On-Demand Rubicon Swaybar Disconnect



Part number	Description	Quantity
EVO-20015ANO	EVO No Limits On-Demand Main Body	1
EVO-20016	EVO No Limits On-Demand Piston	1
EVO-770056	EVO No Limits On-Demand Hardware Pack	1

**The EVO No Limits On-Demand requires on board air supply (not supplied). ARB large compressor and solenoid, and EVO Air Compressor Mount EVO-1097 (sold separately) can be used.**

**Pressure should be regulated between 70 and 100 PSI**

**It is recommended to use an AEV ProCal Module or similar computer programmer to turn off the swaybar function light on your dashboard. Follow directions included with programmer.**

**When disconnected, never exceed 20mph. Disconnect for off road use only. Always drive connected when possible.**

1. Swing the retention clip to the driver side holding the electronic connector in place. Remove connector.



2. With a 15mm wrench remove the three bolts that connect the actuator to the swaybar.



3. Remove factory swaybar actuator.



4. Carefully slide/roll the 2 small O-rings into the 2 grooves on the piston (bright aluminum part)



5. Hand thread the supplied air fitting into the main body a full turn. Be careful not to cross-thread. Using a 13mm wrench, tighten the air fitting into the threaded hole in the main body (black anodized part)
6. Place the large O-ring in the groove on the main body
7. Lightly oil the piston with a petroleum oil (motor oil, trans fluid or similar will work) and slide the O-ring side of the Piston into the Cylinder



8. Install your fully assembled No Limits On-Demand into the opening on your swaybar using the 3 bolts supplied and a 17mm wrench. Be sure the piston fits into the recess inside the Rubicon Swaybar.
9. Connect an air line from your existing on board air system to the fitting on the No Limits On-Demand body.
10. To test the system, park the vehicle on level ground and remove a swaybar link on 1 side. Verify that the disconnected side of the swaybar moves freely when the No Limits On-Demand engaged and that it is fixed when disengaged.

If your swaybar is not disconnecting, remove the 5 bolts clamping the Rubicon swaybar disconnect housing together. Carefully disassemble, making note of how it comes apart and where each part goes. Clean and re-grease the sliding collar and gears. Reassemble in the reverse order it came apart.



EVO-1156

## EVO MFG Chromoly Sport Cage



Bill of Materials

Part number	EVO-1156 Description	Quantity
EVO-12148	EVO Sport Cage A-Pillar Support Driver	1
EVO-12149	EVO Sport Cage A-Pillar Support Passenger	1
EVO-12150	EVO Sport Cage Dash Cross Member	1
EVO-12151	EVO Sport Cage Upper Cross Bar	1
EVO-12152	EVO Sport Cage Center Bar	1
EVO-12172	EVO Sport Cage Connector Plate Driver	1
EVO-12173	EVO Sport Cage Connector Plate Passenger	1
EVO-12174	EVO Sport Cage Center Bar Closeout	1
EVO-770059	EVO Sport Cage Hardware Pack	1

Note: This install requires trimming of interior plastic fascia and sound bar and drilling into body sheet metal. Do not install if you are not comfortable with this.

Note: A standard tool set, drill, drill bit set, Dremel or barrel sander and Torx Set are needed for this install. If you have a factory soft top, you will need a barrel sander or a coarse round/crescent file.

Note: Adding padding on all overhead areas is recommended. Split foam wraps are available online and at most hardware stores.

If applicable, it's best to test fit of raw parts before powdercoat/paint.

Before beginning install, follow your owner's manual instructions to remove the top (soft or hard) from your vehicle

Note: Do not fully tighten any bolts until all bolts are installed and threaded.

1. To remove the front doors, unplug wiring harness under the dash and release the limit strap from the metal hook on the door sill.
2. Remove the nuts on the bottom of the door hinges using a Torx size T-50.
3. Carefully lift doors out of hinges and store them in a safe place.
4. Remove the windshield visors by removing 2 screws holding each in place using T20 Torx
5. Remove the plastic fascia in the upper corners of the A-pillar windshield frame. They are held in place with panel clips and a panel/body clip tool is recommended for removal. On the side of the A-Pillar (pictured), there is a panel clip that requires unscrewing with a Phillip's screwdriver before it can be popped out with the panel clip tool.
6. If the vehicle is equipped with a microphone, it will need to be unplugged from the wiring harness on the driver side.
7. Remove plastic panels on the A-pillars along the windshield frame. These are also held in using only panel clips and a panel clip or similar tool is recommended for removal
8. Remove the panels from each side of the dash. Again, these just clip in and can be removed by applying pressure to the front of the panel (by the door sill) to lift the rear of the panel (the curved part be the air vent). You can then lift the panel and pull it off using gentle pressure (Be careful not to damage the dash clips).
9. Use a 10mm socket to remove the sound bar. It is held in with 6 bolts, 3 on each side (passenger side bolts are shown). Unplug it from the wiring harness on the top of the passenger side.



10. Unzip the fabric covering the bars over the front doors and remove the foam pads. These are held on with panel clips and can be pulled straight down and removed.

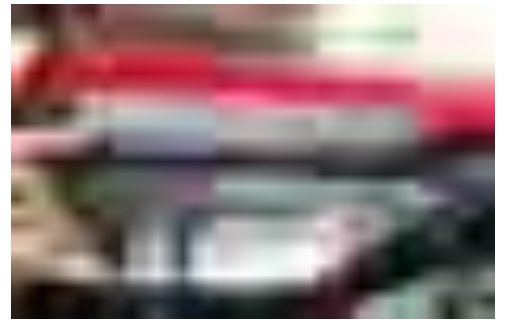

11. At the top corners of the windshield, remove the 2 bolts pictured using a 13mm socket. Save these bolts for use later.



12. If equipped, remove panel clips holding the wiring harness to the windshield frame. Wiring should be free, as shown.

13. Use a 13mm socket to remove the upper door hinge on both front doors (only remove the upper hinge).

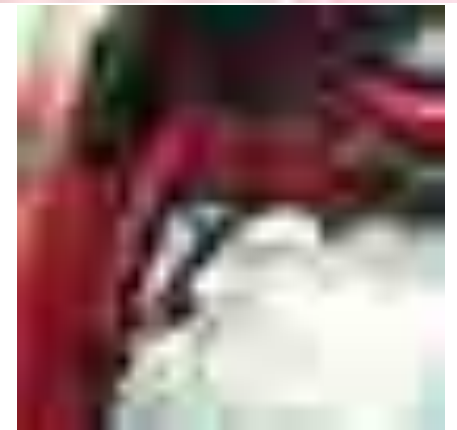

14. Attached at the end of these instructions is the driver side drill template. Verify the scale of the template by measuring the overall length (noted on template). If the length is not 12" do not use the template.

15. Only once the template has been verified, cut the template out along the outer lines and use it to mark and center punch the 3 holes on each side to drill. Align lower corner of template with the notch near the bottom of the door sill (The notch is even with the top of the lower hinge). Keeping the notch lined up, hold the edge of the template flush with the edge of the door sill. Keeping the edges flush, roll the template around the bend as shown. Carefully mark all 3 hole centers.

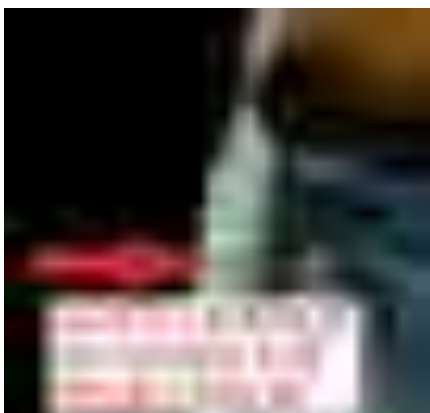

16. Once you have checked and are sure of your marks, center-punch each hole.

17. Again only if you are sure of your marks and the upper hinge is removed, pilot drill the holes and then drill them out using a 25/64 drill bit



18. Along the side of the dash, in the place where the plastic panel was removed in Step 8, attach clip nuts to the lower 2 tabs, as shown, with the thread side inward.



19. Install only the driver side A-Pillar Support Bar (do not install the passenger side A-Pillar Support at this time. That will be installed after the Dash Cross Member). This can be done by first sliding the lower bolt plate behind the door sill, and then rotating the top toward the windshield. Do not bolt into place at this time.



20. The fascia pieces that fit in the upper corners of the windshield will need to be trimmed in 2 places to reinstall. Do this carefully and check the fit as you go, you can always trim more if needed.

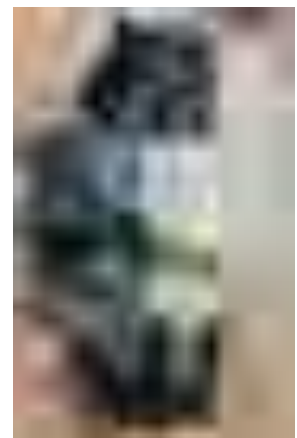
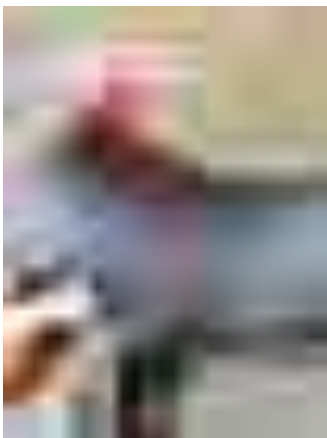



21. Make sure that the wiring harness and any other wires (such as an s-Pod) are tucked behind the A-Pillar Support and out of the way. Across the top of the windshield, make sure the wiring is out of the way of the windshield visor and not pinched.



22. If equipped with a microphone, you will need to plug this back into the wiring harness before bolting the A-Pillar support back into place. Make sure this wire comes out on the outside as shown. The plastic fascia from Step 20 will need to be trimmed before the microphone is plugged in.

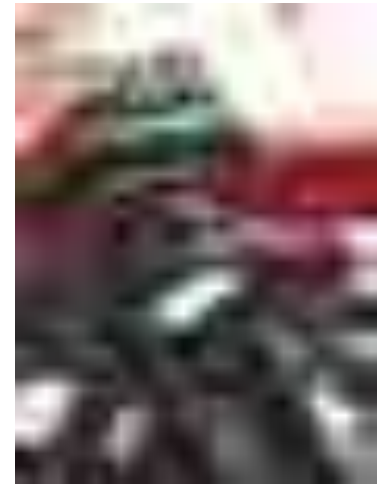

23. Slide the Driver side connector plate (pictured with bolt flap facing up) between the top of the A-Pillar support and the windshield frame making sure the holes on both align with the threaded hole in the top of the windshield frame. The connector plate should be sandwiched between the windshield frame and EVO A-Pillar Support.

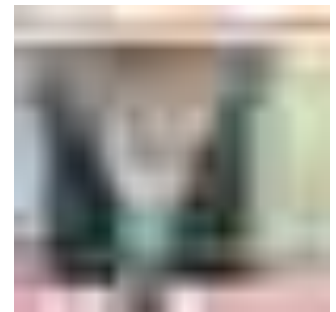

24. With the wiring in place, use a 13mm socket to thread the supplied M8 bolt through the A-Pillar support and connector plate and into the top of the windshield frame. Be sure to tighten this enough to pull the A-Pillar Support all the way up to the top of the windshield frame, but do not fully tighten at this time. The A-pillar should be lifted to the windshield frame but still relatively loose.



25. Using a 13mm socket, thread one of the bolts removed in Step 11 through the A-pillar support and into the side of the windshield frame. Do not fully tighten at this time
26. Verify that the 3 holes drilled in the door sill in Step 17 are in the correct location. If they are not, mark the corrections that need to be made on the door sill and remove the A-Pillar Support Bar. You can use a 7/16 drill bit to open the holes up or use a rotary file, Dremel, or similar tool adjust the holes drilled in the door sill to better align with the threaded holes on the A-Pillar support. Repeat the above install and recheck.
27. Use a 9/16 socket to thread the supplied 3/8" x 1" long bolts with washer and lock-washer through the drilled holes and into the bolt plate of the A-Pillar support at the 3 locations on the driver's side. Do not fully tighten at this time.
28. With only the Driver A-Pillar Support loosely installed (and not the Passenger A-Pillar Support), lay a towel, a sheet of cardboard or something similar over the dash to protect it and then place the Dash Cross Member in place, across the dashboard. Be careful to not damage your windshield or dash.

29. Use a 9/16 socket with extension to thread 2 supplied 1" long bolts with washer and lock washer through the driver A-Pillar Support and into the Dash Cross Bar. Thread both bolts but do not fully tighten at this time



30. Thread 2 of the supplied black button head screws through the 2 small holes near the bottom of the A-Pillar Support and into the clip nuts installed in Step 18.
31. Following the same steps used to install the driver side, install the Passenger side A-Pillar Support and Connector Plate. Be sure not to tighten the bolts fully at this point.

32. Thread 2 supplied 1" long bolts with washer and lock washer through the passenger A-Pillar Support and into the Dash Cross Bar. You may need to loosen the driver side bolts (from Step 29) to help these to align.

33. With the factory tubes above the front doors clear of padding, install the Upper Cross Bar by angling it into place between the tubes, as shown. Note that the bolt holes on the long side face the front of the vehicle and the channel faces up. This may require a light tap from a rubber mallet to fit between tubes.



Note: If the Upper Crossbar is too tight, you can remove the 3<sup>rd</sup> bolt pictured in Step 11 and spread the tubes slightly. Replace the bolt once the cross bar is in place.

34. Hold the crossbar flush against the connector plates and verify that the 2 holes on each side line up. You may need to slightly loosen the bolts from Step 24.

35. Put the center bar in place by aligning the slots with those on the cross bar.

26. Mark the 6 holes shown (2 holes above each door and 2 on the center factory crossbar).

27. Check your marks, remove the center bar and slide the Upper Cross Bar back to clear the marks. Center-punch your marks.



28. Only if you're sure of your marks and have center-punched them, pilot drill the holes, and then drill them out to 3/8. Note: If you have a soft top, be sure the holes are to the left and right of the plastic door surround C-mount.

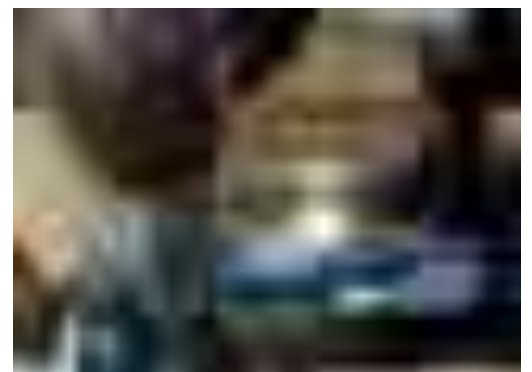

29. Slide the Upper Cross Bar back into place and reinstall the Center Bar. 1<sup>st</sup> thread 2 of the supplied 3" bolts, washers and locknuts through the holes drilled and the outer bolt plate on the crossbar. With these threaded, thread the supplied



1" bolts through the connector plates. Note: If you have a soft top, it is highly recommended to clearance the inside of the door surround C-mount to fit the bolt plate. This can be done with a file, barrel sander or similar tool. If you choose not to clearance the C-mount, then do not install the outer bolt plate. This process is detailed on last page of these instructions.

30. Thread the remaining 2 supplied 1" bolts through the Upper Cross Bar and the Center Bar, as shown.



NOTE: If you are installing EVO-1157 Rear Bar and/or are installing EVO-1167 B-Pillar Cross Bar follow those instructions at this point.

31. Thread the supplied 2 1/2" bolts through the Center Bar and factory center crossbar.

32. With all bolts loosely installed, work your way from the top down and left to right, fully tightening all bolts. Start with the Center Bar and Upper Cross Bar, then windshield frame, then the Dash Cross Bar and finally the door sill bolts.



33. To install the closeout on the underside of the Center Bar, start by attaching clip nuts to the 6 bolt tabs. Be sure the threads are on the inside, as shown. Note: If you are going to install a radio or something similar on the underside of the Center Bar, you may need to trim the Closeout or omit it.



34. With the clip nuts installed, put the closeout in place and use a 1/8 Allen wrench to thread the black button head cap screws through the Center Bar and into the clip nuts.

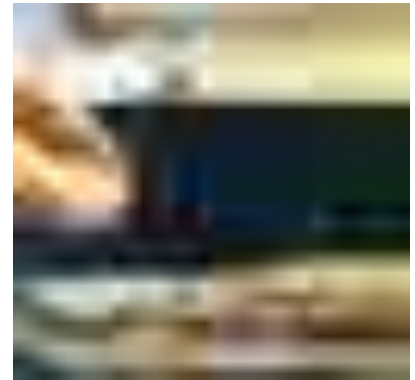

35. Thread the 4 Flat Head 1/8 Allen screws into the clip nuts installed in the dash in step 18.

36. The sound bar will need to be trimmed before reinstalling.

Loosely bolt the sound bar up into place and mark where the top will need to be cut. If you also have the rear bar installed, mark the back of the sound bar too.

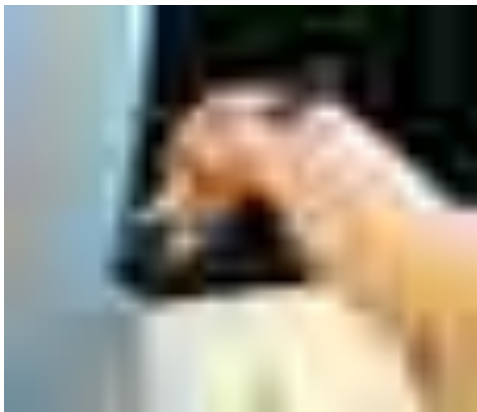

37. With the top of the sound bar marked, measure and mark 1 3/8" down from the top of the sound bar on both sides.



38. Connect your marks and carefully make your cuts. Be very careful not to cut the wiring in the rear of the bar. Depending on the year, it may be wrapped in foam (pictured) or may be exposed. Make shallow cuts to avoid damaging this wiring.



**Note:** When marking and cutting, be careful not to cut too much, you can always cut more off if it is too tight, but you can't put more on.

39. Replace sound bar. Verify that the trimmed sound bar fits. If not, mark where additional trimming is needed, remove the sound bar and make the necessary adjustments.



Note: A file can be used to clean up the cuts in the sound bar.

40. Replace foam padding above front doors and trim where indicated, to accommodate Upper Cross Bar.  
41. The fabric can be folded in on itself, as shown, and zipped for a clean transition at the Upper Cross Bar.  
42. Reinstall the windshield visors.



43. Reinstall/align the door hinges removed in Step 13 and replace the doors and top (trimming of top may be required)

Note: If you have a factory soft top, follow Steps 43-45 to clearance the door surround C mounts. This process may vary for aftermarket tops, adjust as needed.

44. Loosely install driver side front door surround at B-pillar with factory bolt and press C mount over EVO Bolt plate. Mark where the C mount needs to be sanded/filed to clear the round bolt plate installed in Step 29. Similar to picture below, about 1/8 inch of material will need to be removed in this section.

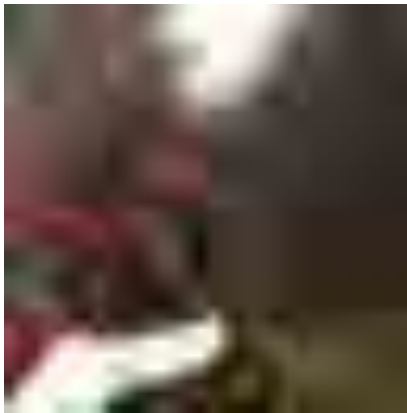

45. Remove the door surrounds and use either a barrel sander or a coarse round/crescent file to remove the material marked in the previous step.



46. Install the door surrounds and verify the fit. If necessary, sand/file again (this may require multiple iterations to achieve an acceptably fit). Note: depending on the holes drilled through the tubes, the C-mount may need to be clearanced around the bolts/washer.

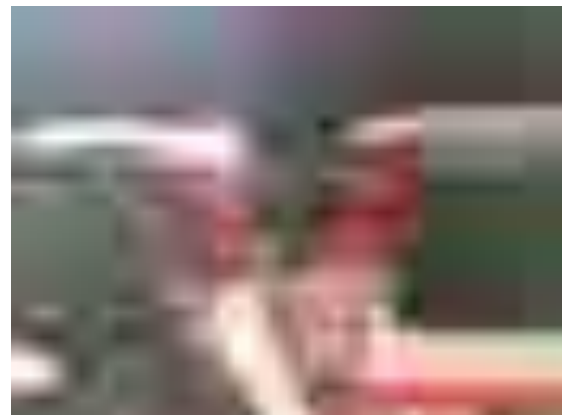

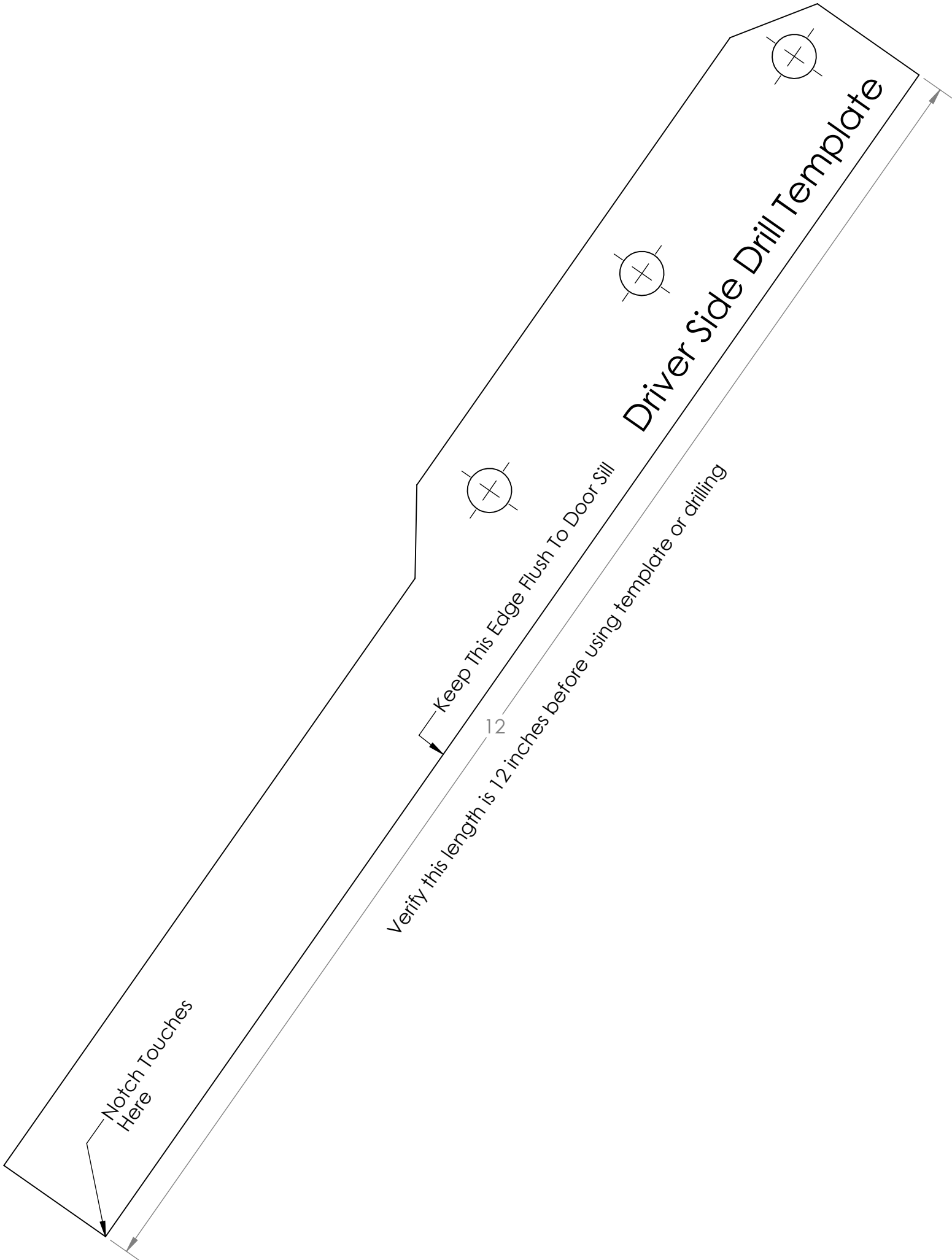



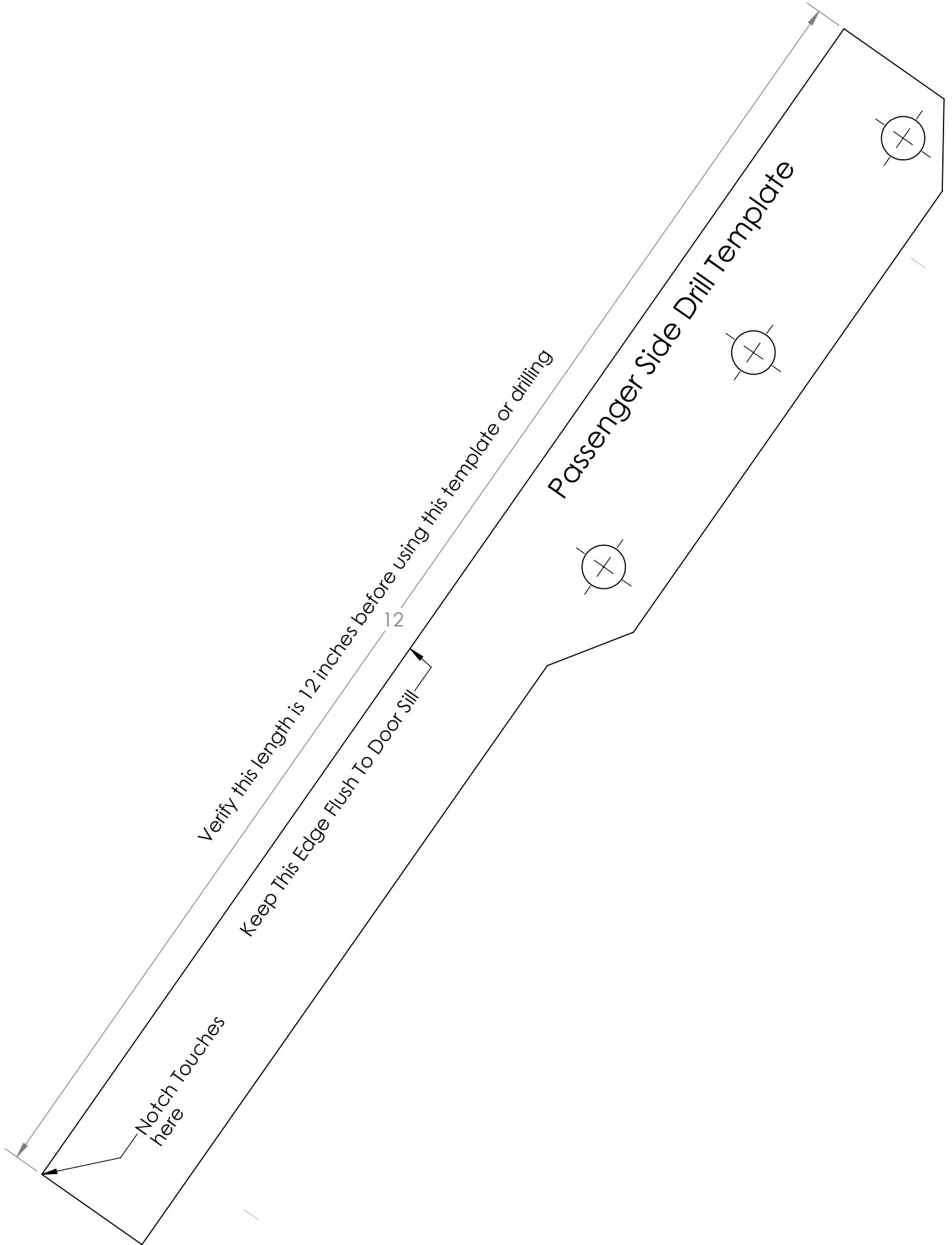

Notch Touches  
here

Verify this length is 12 inches before using this template or drilling

12

Keep This Edge Flush To Door Sill

Passenger Side Drill Template

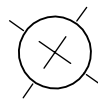



## EVO-1157

### EVO MFG Chromoly Sport Cage Rear Bar



#### Bill of Materials

Part number	EVO-1157 Description	Quantity
EVO-12153	EVO Sport Cage Rear Bar	1
EVO-770061	EVO Sport Cage Rear Bar Hardware	1

Note: This install requires trimming of interior plastic fascia and drilling into body metal. Do not install if you are not comfortable with this.

Note: This product is intended to fit 4 door JK Wranglers only

Before beginning install, follow the owner's manual instructions to remove the top from your vehicle

Note: If installing at the same time as EVO-1156 Chromoly Sport Cage, follow directions on EVO-1156 to determine when to install EVO-1157 Rear Bar

1. Unzip the fabric covering the rear cross bar of your vehicle.
2. Remove the dome light using a panel clip tool or similar tool.

NOTE: If you're installing the EVO MFG Chromoly C-Pillar Cross Bar (EVO-1168), follow those instructions at this time.



3. With the holes drilled in the factory B-pillar crossbar and front Center Bar in place, lay the rear bar in place, channel up, over the top of the front center bar and align the holes with those on the center bar. Stacking order from bottom to top is factory cross bar, EVO Front Center Bar, EVO Rear Bar and (If installing) EVO B-Pillar Cross Bar.



4. Mark the 2 holes to drill on the rear factory cross bar. If you have installed the EVO MFG C-Pillar Cross Bar (EVO-1168), these holes will already be cut and you can skip to Step 6.
5. Remove the EVO MFG Rear Bar. Center-punch your marks, pilot drill, and then drill out to 25/64". It is recommended to put a tarp, drop cloth, or something similar to protect the interior from metal shavings from the drill.



6. The fabric cover will need to be cut to allow the rear bar to pass through. With the bar in place, mark the fabric on both sides of the bar to cut.

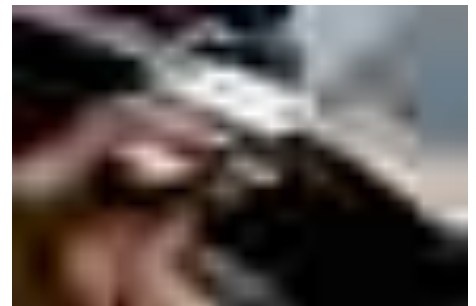

7. Make a small vertical cut on both sides of the Rear Bar and a horizontal cut between them



8. Slide the Rear Bar through the opening in the fabric and put it in place, lining all the bolts holes up



9. Thread the 2 supplied 2 1/2" bolts through the rear cross bar. In the front, thread the 2 bolts supplied with the EVO MFG Chromoly Sport Cage (EVO-1156) through the center bar and factory B-Pillar cross bar.

10. After fully tightening the Rear Bar to the C-pillar cross bar, reinstall the dome light and zip the fabric cover back up.



Note: Continue following instructions for EVO-1156 to complete the EVO MFG Chromoly Sport Cage install.

Note: The hardtop may need to be clearanced around the bolt heads on the top of the B-pillar.



EVO-1158

EVO Front JK Fenders



### Bill of Materials

Part number	EVO-1158 Description	Quantity
EVO-12154	EVO Front JK Fender Driver	1
EVO-12155	EVO Front JK Fender Passenger	1
EVO-12198	EVO Front JK Fender Bracket Driver	1
EVO-12199	EVO Front JK Fender Bracket Passenger	1
EVO-12200	EVO Front JK Fender Brace	2
EVO-770067	Front JK Fender Hardware Pack	1

**Note:** This product requires removal of the front factory fenders. If your fenders are already removed, skip to **Step 7**.

1. To remove your front factory fenders, begin by drilling out the 3 plastic rivets at the rear of the fender and removing them. Use a 3/16" drill bit for these.
2. Remove the panel clips using a panel clip tool or similar tool. There are a total of 4 clips.
3. Using a 10mm wrench remove the 5 bolts holding the fender in place. Save these bolts for reuse later.

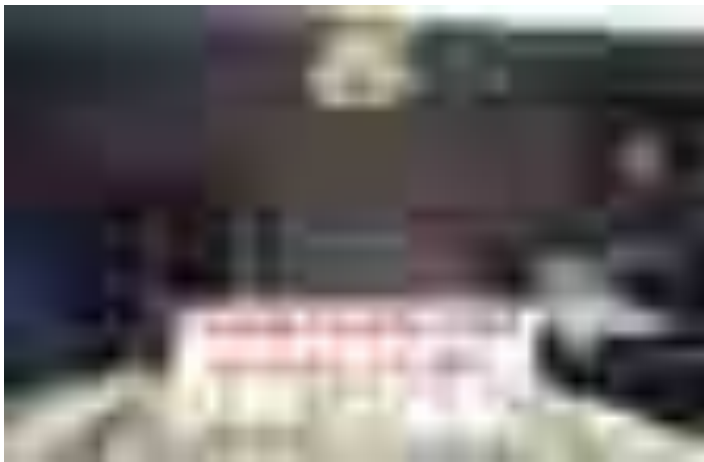

4. You should now be able to work your inner fender out of the wheel well.
5. With the inner fender removed, the rest of the fender will snap out.
6. The clips that held the fender in place can be removed by squeezing the inside of the clip together, as shown, from the inside of the body sheet metal.



7. Use 2 of the bolts removed in **Step 3** to bolt the fender mounting bracket (EVO-12198/EVO12199) to the 2 holes along the underside of the wheel well (as pictured). The upturned flange should sit behind the factory sheet metal and the bolt holes should be aligned with the holes circled in the picture.



8. With the fender bracket in place, use the 5/16 Button Head Screws, washers and locknuts to loosely mount the front fender. Cap screws use 3/16" Allen wrench and Locknut use 1/2" wrench or socket.

9. With the fender loosely bolted in place, mark the 2 holes pictured to be drilled.
10. When you have double checked and are sure of your marks, remove the fender and center punch the marks.
11. Pilot drill the holes and then open them up to 5/16.



12. With the holes drilled, fit the lower gusset (EVO-12200) in between the body outer sheet metal and the body structure as shown. Be sure the part is oriented in the same direction.
13. Align the holes you drilled with the holes in the side of the gusset. Mark the holes on the inside of the body structure, as shown (Note that passenger side is shown).



14. With the holes marked, center punch and drill to 5/16”.

15. Loosely bolt the gusset to the inner holes drilled in **Step 14** using supplied 5/16” button head screws, washers and locknuts.

16. With the mounting bracket (EVO-12198/EVO-12199) and gusset (EVO-12200) in place, loosely bolt the fender in place using the supplied 5/16” button head screws, washers and locknuts.

17. Once all the cap screws and locknuts are threaded, go back and fully tighten all of them.







EVO-1158

EVO Rear JK Fenders



#### Bill of Materials

EVO-1158		
Part number	Description	Quantity
EVO-12156	EVO Rear JK Fender Driver	1
EVO-12157	EVO Rear JK Fender Passenger	1
EVO-770068	Rear JK Fender Hardware Pack	1

Note: The rear fenders require installation of supplied nutserts (rivet nuts). This can be done with a nutsert tool (thread size 5/16-18).

**Note:** This product requires removal of the rear factory fenders. If your fenders are already removed, skip to **Step 5**

1. To remove the rear factory fenders, use a 3/16" drill bit to drill out and remove the plastic rivets holding the inner fender liner to the fender. There are 6 plastic rivets per side.
2. Remove the 5 panel clips on the inner fender liner using a panel clip tool or similar tool. There are 2 clips at the bottom, 2 at the top and 1 at the front of the fender liner.
3. Once the rivets and panel clips have been removed, work the inner fender out of the wheel well.
4. With the inner fender removed, the rest of the fender will snap out.
5. Remove the body clips that held the fender in place.



6. Once the factory rear fenders have been removed, the 6 holes pictured need to be drilled out and have nutserts installed. Do not drill or install nutserts in the top 2 center holes. Drill size is 17/32".



7. With nutserts installed, used supplied 5/16" button head screws, washers, and locknuts to loosely, secure the fenders to the 2 center holes (The holes without nutserts). Note, do not fully tighten at this time.
8. Starting at the rear of the vehicle, thread the remaining 5/16" button head screws and washers into the nutserts, do not fully tighten at this time. (Note: Start at the rear nutsert and work towards the front)
9. Once all bolts are threaded, go back and fully tighten all hardware.



EVO Manufacturing  
Jeep Wrangler JK/JKU  
JK/JKU Tailgate Tire Carrier  
EVO- 1162





Before starting installation procedure please read <http://evomfg.com>Returns-Warranties-Shipping>

---

**CAREFULLY READ AND FOLLOW ALL INSTRUCTIONS IN THIS MANUAL AND KEEP FOR FUTURE REFERENCE. IF YOU HAVE ANY QUESTIONS ABOUT THE PRODUCT CALL EVO MANUFACTURING. FAILURE TO FOLLOW GUIDELINES COULD RESULT IN MALFUNCTION OF PARTS OR INJURY. PLEASE HAVE A TRAINED PROFESSIONAL ASSIST WITH OR INSTALL ALL PRODUCTS. INSTALLING EVO MFG PRODUCTS OR KITS DEMANDS SPECIFIC KNOWLEDGE, TOOLS AND EXPERIENCE. GENERAL KNOWLEDGE OF HOW TO USE LATER SPECIFIED TOOLS AND/OR LIMITED EXPERIENCE WITH EVO MFG PRODUCTS MAY NOT BE ENOUGH TO PROPERLY COMPLETE THESE TASKS. SOME OF EVO MFG PRODUCTS MAY REQUIRE TWO OR MORE PEOPLE TO INSTALL SAFELY AND CORRECTLY. DO NOT ATTEMPT ALONE, ALWAYS ENLIST THE HELP OF TRAINED PROFESSIONAL WHEN NEEDED.**

**Notes: Set Up Before installation**

**\*Powder coated tire carriers are coated exterior only, additional coating/paint should be checked and sprayed by installer before install.**

**Carefully remove factory spare tire, use proper precaution**

**Unless otherwise specified, keep all mounting bolts loose (installed but not torqued) we will torque later at the end of complete installation**

**READ BEFORE INSTALL:**

\*Some backspacing wheels/tire width combinations (small backspacing/wide tires) may require a single wheel spacer to properly mount to tire carrier. While this tire carrier will mount/clear a larger tire, we currently are recommending max 37".

\*You will need a Torx bit set ranging from T6– T55 to complete installation.

\*It is recommended to NOT open tailgate until installation is complete. Some preload adjustments may need to be made after complete installation. Do so as needed.

\*It is generally a good idea to apply Loctite to all threaded bolts.

\*ALWAYS wear safety glasses and other approved safety gear when working on a vehicle.

\*All supplied bolts torqued according to chart at end of instruction.

\*It is recommended all installation be performed by a trained professional. Some modification may have to be done.

\*Paint all unfinished surfaces after install is complete.



Parts included: Table below shows EVO Tailgate Tire Carrier.

Description	#	Part #	Quantity
EVO Tailgate Tire Carrier	1	EVO-12161	1
Bolt Plate	2	EVO-12162	1
Wheel Mount	3	EVO-12163	1
Hinge Bracket	4	EVO-12165	2
Tire Carrier Spacer	5	EVO-12166	3
Tire Carrier Hinge Tubes	6	EVO-12167	2
Lower Door Catch Bracket	7	EVO-12177	1
Upper Door Catch Bracket	8	EVO-12178	1
Tire Carrier Hardware Pack	9	EVO-770058	1





#### **Recommended Tools:**

- An Extra Long T50 Torx bit is recommended to make this install more efficient
  - Wrench and Sockets
  - Allen Set
- 



#### **Safety Steps for installation**

- For installing EVO MFG products always use wheel chokes to block rear tires from rolling.
  - Always make sure you have everything necessary ready before install.
  - If you have to, carefully lift front of vehicle by front frame rails extending suspension until tires leave the ground, place frame on approved jack stands for vehicle. Verify all lines/wires are not over extended.
  - Remove tires if needed for easier install.
  - Make sure to wear safety equipment (eye protection, hand protection, foot protection etc.) at all times during installation.
  - Make sure all safety precautions have been taken.
  - Always check and replace any part of vehicle that is worn or broken before starting install.
  - Do not mix anything EVO with weaker alternatives.
  - It is generally a good idea to apply liquid threadlock to all bolts.
  - Tighten included hardware to torque specifications in bottom table unless it is otherwise specified, factory bolts should be torqued to factory Jeep specifications.
- 





## **INSTALL**

1. Check that the barrels are clean and free of coating. Light sanding may be required. Install the 4 hinge bushings and 2 inner sleeves into both hinge barrels. Use a light oil (WD-40) inside the barrel, these should have a snug fit. A light tap with a rubber mallet may be required to seat the bushings, but do not force them. Hand install at first and only tap to seat them. These will not require further oil, just during install.
2. Using 4 supplied 7/16 bolts, 4 lock nuts, and 8 washers (11/16 wrench and socket), secure the bolt plate to the tire carrier. There are location options, all the way up is recommended for clearance, but lower locations will increase rear window visibility. You will need to access the inside of the Tailgate Tire Carrier to reach the nuts so be sure to do this before bolting it to the tailgate.





3. Using a 3/32 Allen wrench and 11/32 wrench (or adjustable) install the rubber bumper onto the hinge as shown. On the top hinge, install the bumper in the bottom hole. On the bottom hinge install the bumper in the top hole.
- 



4. Using a T30 Torx bit, remove the 2 screws holding the door catch to the inside of the tailgate, as shown. With the bolts removed, pull the door catch out from the body of the vehicle.
- 







5. Remove the 8 bolts around the vent in the center of the tailgate as well as the plastic trim covering the hinges. Set the bolts aside to reuse later.
- 



6. With the tailgate closed and your vehicle on level ground, remove the factory hinges by removing the 4 bolts on the tailgate (13 mm wrench) and the 6 bolts on the body (Torx T50). Set bolts aside to reuse later.
- 



Note: Do not open your tailgate after step 6!

7. Using the 6 T50 Torx bolts removed in step 6, loosely bolt the Tailgate Tire Carrier hinges to the body. Don't tighten the hinges at this time.
- 





8. Install the Tailgate Tire Carrier into the hinges and slide the supplied 4" long 9/16 bolts, washers and lock nuts through to secure it to hinges. Do not tighten at this time.
- 



9. Using the 4 bolts that mounted the factory hinges to the tailgate in step 5, slide them into the 4 holes from the outside as shown. On the top, hang 1 of the supplied oval spacers and on the bottom, hang 2 spacers from the inserted bolts as shown.
- 



10. Slowly swing the Tailgate Tire Carrier closed being sure the bolts and spacers stay in place. As the Tire carrier comes flush with the tailgate, make sure the 4 bolts line up with the 4 holes in the tailgate. Use a 13mm socket with extension to thread the right side bolts first, then the left. Do not tighten them at this time.
- 





11. Using 6 of the 8 bolts that were surrounding the vent in the center of the tailgate (removed in step 5), thread them into the remaining 6 openings in the Tailgate Tire Carrier. These can be accessed using a 13mm socket and extension as shown.

12. Once all the bolts are threaded to the tailgate, fully tighten all bolts to tailgate only.

---



Note: If you don't have an extra-long T50 bit, this install can still be done, but it may require 2 people. After completing step 12, start by opening the tailgate and applying upward pressure on the tire carrier and tailgate. Tighten the bolts on the inside of the hinges (Pictured in step 14). You then need to check and verify that the tailgate closes and latches properly. If it does not, loosen the bolts, adjust and retighten. It may take several tries.

13. With the tailgate closed use the Extra Long T-50 bit, tighten the 2 bolts on the passenger side of each hinge (1 bolt per hinge). Note: If you do not have an extra-long T50 bit. With the tailgate closed, you will need to remove the 9/16 bolts from the hinges. Leaving the tailgate latched, carefully swing the tailgate out from the hinges to access and tighten the remaining 2 T50 bolts.

---





14. Open the tailgate and tighten the 4 bolts on the inside of each hinge (2 bolts per hinge) Note: If you're following the instructions for install without the extra-long T50 bit, you already tightened these bolts after step 12

15. Tighten the 9/16" bolts through the hinges.

Note: Because the hinges are designed to have a high quality, precision fit, they may feel slightly resistive at first.



NOTE: Steps 16-19 must be followed closely to prevent rattle/tire vibration.

16. Loosely bolt the Wheel Mount to the Bolt Plate using 3 supplied 7/16 bolts, locknuts and washers. Make sure this part can still slide





17. Install your wheel and tire and fully tighten the lug nuts to the wheel mount. With the tire secured, slide it toward the tailgate until the tire contacts the tire carrier. On the slider, mark on the bolt plate where it stops (this is easier to mark with the tailgate open). Note: If your wheel/tire combo is beyond the reach of the support mount, you will need to use a wheel spacer.

---



18. Once slider is marked, remove the wheel and tire.

19. Move the slider back (toward the tailgate) to cover the mark you made in step 17 (you should move it back around 3/16 in over your mark). Fully tighten the 3 bolts on the slider so that it can no longer move.

---





Note: Steps 20-22 are optional for reinstalling the door catch

20. On the door catch pin, one side has a wider mushroom head than the other. Using a 3/8 drill bit, drill this head until the mushroom is removed. Remove the bracket. Do Not Drill Through Plastic Door Catch



21. Use the supplied 1/4" bolt and locknut (7/16 wrench and socket) to bolt the supplied slotted mounting bracket to the door catch. Do not use the washers. Do not overtighten, tighten just enough that the catch will rotate between brackets.

---



22. Reinstall the door catch with the new bracket. Start by loosely bolting the door catch back with the new bracket and supplied washers as shown. While holding the catch in place, gently close the door until it is reinserted into the vehicle body. Once the catch is back in place, open the tailgate and slide the bracket all the way toward the vehicle and tighten the screws as shown.

---





23. Put the wheel and tire on and fully tighten the lug nuts.

Note: If you have/are planning to install EVO-1120 Tailgate Jack Mount, it can be installed using the 2 remaining M8 bolts removed in step 5.

---



---

After Install:

- Tighten all bolts securing purchased parts to specified locations.
- After completing installation using provided instructions, go through all steps again to make sure nothing was missed, not tightened or improperly assembled.
- Some components may need to be purchased separately.
- Check turn signals, headlights, fog lights (if applicable), taillights, blinkers and windshield wipers.
- Adjust mirrors, speedometer and headlights if needed.
- Make sure all gauges are fully operational.
- Drive the vehicle slowly for a couple minutes, looking and listening for abnormal noises while driving. After modification of a vehicle there will be differences in driving experiences and capabilities, be mindful of that.
- Inspect and Retorque all Bolts after 500 miles of completed installation and regularly thereafter.
- Some modification may be required.



Recommended Torque:

Size	Grade 2		Grade 5		Grade 8		18-8 S/S	
	Coarse	Fine	Coarse	Fine	Coarse	Fine	Coarse	Fine
<b>#4*</b>	-	-	-	-	-	-	5.2	-
<b>#6*</b>	-	-	-	-	-	-	9.6	-
<b>#8*</b>	-	-	-	-	-	-	19.8	-
<b>#10*</b>	-	-	-	-	-	-	22.8	31.7
<b>1/4</b>	4	4.7	6.3	7.3	9	10	6.3	7.8
<b>5/16</b>	8	9	13	14	18	20	11	11.8
<b>3/8</b>	15	17	23	26	33	37	20	22
<b>7/16</b>	24	27	37	41	52	58	31	33
<b>1/2</b>	37	41	57	64	80	90	43	45
<b>9/16</b>	53	59	82	91	115	129	57	63
<b>5/8</b>	73	83	112	128	159	180	93	104
<b>3/4</b>	125	138	200	223	282	315	128	124
<b>7/8</b>	129	144	322	355	454	501	194	193
<b>1+</b>	188	210	483	541	682	764	287	289





## EVO-1163B

### EVO MFG License Plate Relocate



#### Bill of Materials

Part number	EVO-1163B Description	Quantity
EVO-12168	EVO Stud Plate	1
EVO-12169	EVO Mounting Plate	1
EVO-770063	EVO Hardware	1

Note: This product only works with stud mount tire carriers.

Note: This product comes pre-drilled for a variety of mounting configurations (4.5 on 5; 5 on 5; 5.5 on 5; and 8 on 6). You may need to drill/modify to meet your specific wheel/tire combination needs.

Note: Wheel center cap will need to be removed and wheel center hole diameter must be at least 2 ¼ inches

1. With the spare tire removed, position the Stud Plate over the studs on your tire carrier. Make sure the slot faces up.



2. Install the spare tire, sandwiching the stud plate between the tire and tire carrier. Tighten the lug nuts to the studs.



For use as RotoPax mount, proceed to Step 3. For use of license plate relocate, skip to Step 7

3. Slide the Mounting Plate over the Stud Plate and thread the 4" long bolt through and into the nut in the stud plate



4. Use a 9/16 socket with extension to tighten the Mounting Plate until it is flush with the tire.



5. Use the hardware supplied by RotoPax to attach their bracket to the EVO MFG Mounting Plate. (The RotoPax universal mount is shown)



6. The mounting hardware or gas can needs to be pulled tight against the tire to apply tension and keep the gas can from rattling. You will need to use a 9/16 wrench (a ratcheting wrench works well for this) to tighten the bolt until it does. This bolt can be accessed from the underside without removing the RotoPax hardware.



7. To install for use as a license plate relocate and not a gas can mount, thread the supplied  $\frac{3}{4}$ " long bolt locknut and washers through the slot in the center. Slide the bracket to the desired depth and tighten the bolt, clamping the sliders together.
8. Use the supplied #10 screws, bolts and washers to mount your vehicle's license plate to the holes in the top corners of the mounting plate.





EVO-1164

EVO MFG HnT Rear Bumper



#### Bill of Materials

Part number	EVO-1164 Description	Quantity
EVO-12170	EVO HnT Rear Bumper	1
EVO-12171	EVO JK Rear Cross Member	1
EVO-770062	EVO HnT Hardware	1

Note: This product requires cutting of the frame, including permanent removal of the rear cross member and hitch receiver. If you're not comfortable with this, do not proceed with install.

Note: This product will not work with the EVO MFG Rear Double Throwdown (EVO-1008)

1. Remove the factory bumper. It is held in place by 16mm bolts in 6 places. 2 on the inside of the rear cross member and 2 on both sides of the frame rails.
2. If installed, remove the factory recovery hook from the frame with an 18mm socket. Be sure to remove the bolt plate from inside the frame as well.
3. Remove the factory muffler. It is held onto the exhaust with a compression clamp. Loosen this clamp with a ratchet and 15mm socket. Remove the muffler from the 2 rubber hangers, 1 on each side. With the clamp loosened and the rubber hangers removed, add WD-40/light oil and work the muffler back and forth to slide it off the exhaust.

Note: This product is compatible with the factory muffler however removal is required for ease of installation.

4. Remove the 2 rearmost body mount bolts, as well as the 4 nuts under the body mount washers (2 on each side).
5. If keeping the factory muffler or a rear mounted muffler, trim the heat shield 3 inches forward of the factory rear cross member. This can be done with sheet metal snips or a similar tool. Otherwise discard the heat shield.

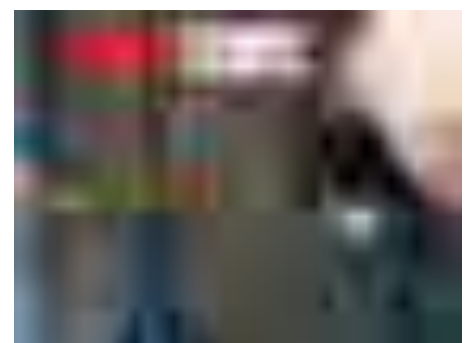
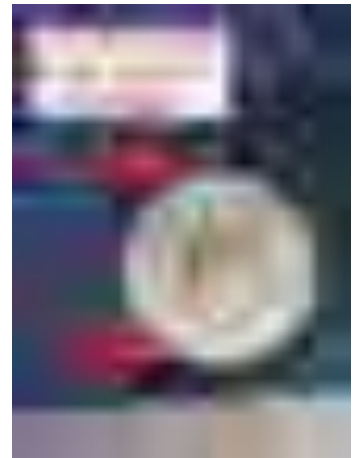
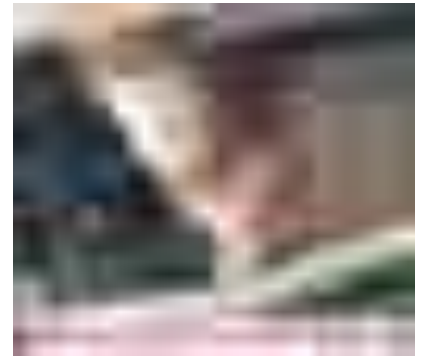

Note: The EVO MFG Rear Cross Member should not be removed once the factory frame cross member has been cut. Be sure that it is painted/powder coated to protect against corrosion before proceeding with cutting of frame.

6. Install the EVO MFG Rear Cross Member with the flat edge facing forward. The large holes on each end should fit around the body mounts. Thread the 4 nuts removed in Step 4 back onto the studs next to the body mounts, with all 4 threaded, tighten them.

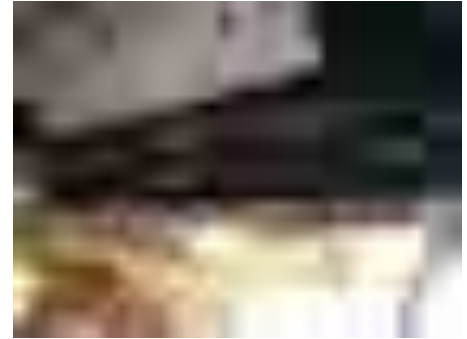

7. The large washers on both body mounts will need to be clearanced before reinstalling. Remove material from one side, as shown, and reinstall. This can be done with a grinder, cutoff wheel or similar tool.



8. With the EVO MFG Rear Cross Member installed, use the supplied template (at the end of these instructions) to mark the end of the frame on both sides to cut. To use the template, first verify the template scale by measuring the noted dimension. If it is not 6 inches, do not use the template. Cut the template out and then line the 2 holes up with the factory bumper bolt holes (bolts removed in Step 1) and mark along the edge with the jog in it.

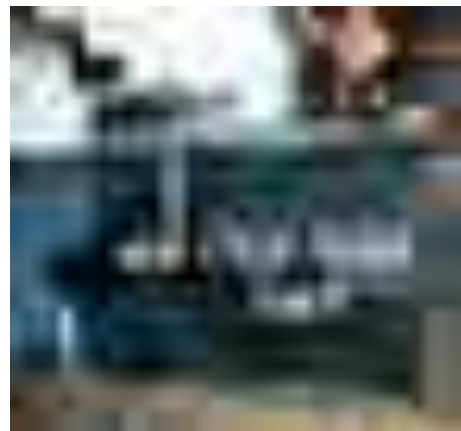

9. Wear safety glasses. Use a reciprocating saw with a metal cutting blade or similar tool and cut along the lines marked in the previous step. Take your time and be careful to not damage the body sheet metal. It may be best to first make a straight cut along the rear body mount edge to remove the cross member, and then make the jog cuts.

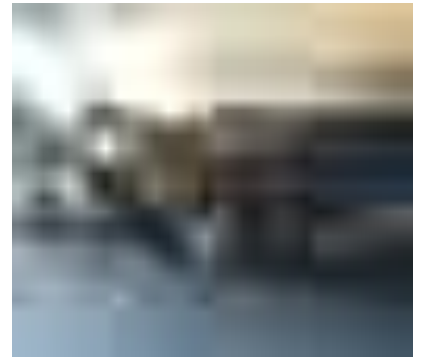

10. Use a grinder/sander to clean up the edge left by the saw and remove any burrs.

11. Paint the exposed metal edge to prevent corrosion. Be careful to avoid getting any paint on the body. Mask body if needed.

12. Fit the EVO MFG Frame Cut Rear Bumper onto the frame (the outer edges of the frame may need to be tapped in with hammer to fit bumper over frame). Thread 4 supplied M10 bolts and washers through the bolt plates and into the frame (2 on each side), as shown. Do not fully tighten at this time.



13. Thread the remaining 2 M10 bolts, nuts and washers through the bottom of the bumper and cross member. Use 17mm wrench and socket to tighten them.

14. With the bumper tightened to the cross member, tighten the 2 bolts on each side into the frame using a 17mm socket.

15. If applicable, reinstall the muffler by working it back onto the exhaust, tightening the clamp and reattaching it to the rubber hangers.

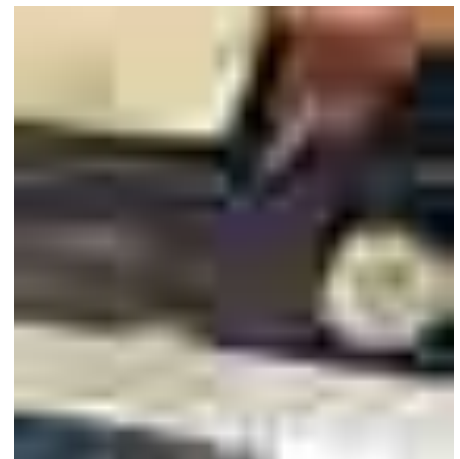







EVO-1165AL(B)

EVO B-Pillar Rockskins



Bill of Materials

Part number	EVO-1165AL(B) Description	Quantity
EVO-12175AL	EVO B-Pillar Rockskin Driver	1
EVO-12176AL	EVO B-Pillar Rockskin Passenger	1
EVO- 770060	B-Pillar Rockskin Hardware Pack	1

Note: This product is intended to fit 4 door JK Wranglers only

**Note: This kit requires drilling into the body of your vehicle. Make sure the B-Pillar Rockskin follows the doors and bodylines of your vehicle to your satisfaction before proceeding with install.**

You only get one shot at correct install. Before drilling, make sure you are satisfied.

**Nutsert tool/Threaded insert tool should be used for installation and can be found online at such places as Amazon, Harbor Freight, and many other tool supply company's web sites. Thread size required is ¼-20**

1. Tape off the B-Pillars Prior to marking and drilling.
2. Only after taping the body off to avoid scratches in the paint, hold the B-Pillar Rockskins against the body and position them to match the body lines and the outline of the doors. Mark the 4 holes to be drilled on each side. Be sure the Rockskins are tight to the body do not move while marking (this may be easier to do with 2 people).



3. Only if you are satisfied with the position of the B Pillar Rockskins, center punch and then pilot drill all the holes into the body sheet metal. You only want to drill through the surface layer of sheet metal, and no deeper.

**Note:** When Drilling Body Sheet Metal, go very slow and use light pressure, the drill may have a tendency to bite in. It is recommended to start small and step up the size of the drill incrementally



4. Use a 3/8" to 25/64" drill bit to open the holes up. Drill sizes can vary, so verify your fitment with the threaded inserts (At this point only check the fit of the threaded inserts, do not install them)
5. Use a countersink (or larger drill bit) to remove the flared edge left around each hole on body.
6. Use threaded insert tool to install threaded inserts/rivet nuts in all holes drilled into the body.



Note: The B-Pillar Rockskins come with 2 sets of hardware to match armor on your vehicle. If your vehicle has flat head hardware (EVO MFG Rockskins) install The B-Pillar Rockskins with countersunk holes facing out to fit the flat head hardware. If your vehicle has button head hardware (EVO MFG Boatside Bombers) install the B-Pillar Rockskins with the counter sunk holes against the body (flat side out).

7. Using a 5/32" Allen wrench to thread the supplied hardware on. Once all screws are threaded, fully tighten them.





EVO-1167

EVO Chromoly B-Pillar Cross Bar



Bill of Materials

Part number	EVO- Description	Quantity
EVO-12184	EVO Chromoly B-Pillar Crossbar	1

Before beginning install, remove the hard top from your vehicle

Note: If installing the rear bar of the EVO MFG Sport cage (EVO-1157), complete that installation first.

1. Use a 10mm socket to remove the 6 bolts holding the sound bar in place. Passenger bolts pictured. Unplug the sound bar from the wiring harness on the passenger side



2. Unzip the fabric at the top of each B -Pillar



3. Use a 13 mm socket to remove the 4 bolts holding the plate on each corner.



4. If your vehicle is equipped with GPS, you will need to unplug the passenger side plate from the wiring harness. This plug is located at the top of the b-pillar behind the interior trim, as shown.

5. If you already have the EVO MFG Chromoly Sport cage installed, remove the 2 bolts from the center of the b-pillar cross bar.

6. Fit the EVO MFG B-Pillar Cross Bar across the factory cross bar as shown.



7. Thread the 2 bolts through the center holes.

8. Fit the EVO MFG B-Pillar Plates on the corners with the factory plates over them, as shown. If equipped, plug the GPS unit back into the wiring harness.



9. Use a 13mm socket to bolt the B-Pillar plates back in place. Use 3 of factory bolts (removed in Step 3) on each side and 1 supplied, longer M8 bolt for the bolt hole closest to the inside, as shown.



10. With the 4 bolts on each side, and the 2 through the middle tightened, zip the fabric covering back up.

**Note:** If you have already installed the EVO MFG Chromoly Sport Cage and trimmed your sound bar, a small additional trim to the front will be required. If not, follow the instructions in the EVO MFG Chromoly Sport Cage instructions to trim the sound bar.

**Note:** When marking and cutting, be careful not to cut too much, you can always cut more off if it is too tight, but you can't put more on.

11. Loosely bolt the sound bar in place and mark where it contacts the B-Pillar Cross Bar to cut.
12. With the sound bar marked, remove it and make your cuts.
13. Reinstall the sound bar and verify that it fits. If not, mark it, remove and trim again.



14. If you have a hardtop, you will need to make a small relief trim for the bolt heads in the center.



**EVO-1168**

**EVO Chromoly C-Pillar Crossbar**



**Bill of Materials**

Part number	EVO- Description	Quantity
EVO-12184	EVO-Chromoly C Pillar Crossbar	1
EVO-770065	EVO- C Pillar Crossbar Hardware	1

Before beginning install, it is recommended to remove the hard top from your vehicle to following the owner's manual instructions.

1. Unzip the fabric covering the rear factory c-pillar crossbar.
2. Remove the dome light and foam padding. These are held in with panel clips. A panel clip tool or similar tool is recommended for removal.
3. Remove wiring harness from factory cross bar, clipped in 3 places.

Note: If you have already installed the EVO MFG Chromoly Sport Cage Rear Bar, you will need to unbolt it as well

4. Use a 13mm socket to unbolt the cross bar. It is held in by 8 bolts, 2 on the top and 2 on the bottom of each corner.

5. Install the EVO MFG Chromoly C-Pillar Cross Bar. Reuse the factory bolts on the top, threading them back into the factory tubes. On the bottom, thread the 4 supplied M8 bolts, washers and nuts through the factory bolt holes. With all 8 bolts threaded, use a 13mm wrench, 13mm socket and extension to tighten these.
6. If you have not yet installed the Rear Bar, follow those instructions at this time. If you have already installed the Rear Bar, bolt it back onto the Cross Bar at this point





7. Reinstall the foam padding, dome light and wiring harness and zip the fabric back up.





EVO-1169

## EVO Sport Cage Grab Handles



### Bill of Materials

Part number	EVO-1169 Description	Quantity
EVO-12186	EVO Grab Handle Driver	1
EVO-12187	EVO Grab Handle Passenger	1
EVO-770069	Grab Handle Hardware Pack	1

**Note:** These grab handles install on EVO MFG Chromoly Sport Cages, after the Sport Cage is installed.

**Note:** Grab handles are intended for entering and exiting vehicle only and not for holding onto while the vehicle is in motion.

1. After your sport cage has been installed, hold the grab handle in place against the A Pillar and Upper Cross Bar, as shown.



2. Keeping the grab handle positioned, mark the holes to be drilled.



3. Double check your marks. When you are sure of your marks, center-punch them and pilot drill.
4. Open each hole up to  $\frac{1}{4}$ ".
5. Use a supplied button head cap screw, washers and, a standard locknut to loosely fasten the grab handle to the top crossbar.
6. Use the remaining button head cap screw, and washers with the supplied locking wing nut to loosely fasten the grab handle to the A-Pillar. Note that the wing nut goes on the inside and can be accessed through the hole on the side of the A-Pillar.
7. With all hardware threaded, use a 5/32 Allen wrench and 7/16 wrench to tighten. Note, the wing nut will bind against a gusset on the inside of the A-Pillar allowing the screw to tighten.



EVO Manufacturing

Jeep Wrangler JL/JT Gladiator

JL/JT Control Arms

EVO- 3082B, 3081B, 3007B, 3006B, 1175B, 1174B





Before starting installation procedure please read <http://evomfg.com>Returns-Warranties-Shipping>

**CAREFULLY READ AND FOLLOW ALL INSTRUCTIONS IN THIS MANUAL AND KEEP FOR FUTURE REFERENCE. IF YOU HAVE ANY QUESTIONS ABOUT THE PRODUCT CALL EVO MANUFACTURING. FAILURE TO FOLLOW GUIDELINES COULD RESULT IN MALFUNCTION OF PARTS OR INJURY. PLEASE HAVE A TRAINED PROFESSIONAL ASSIST WITH OR INSTALL ALL PRODUCTS. INSTALLING EVO MFG PRODUCTS OR KITS DEMANDS SPECIFIC KNOWLEDGE, TOOLS AND EXPERIENCE. GENERAL KNOWLEDGE OF HOW TO USE LATER SPECIFIED TOOLS AND/OR LIMITED EXPERIENCE WITH EVO MFG PRODUCTS MAY NOT BE ENOUGH TO PROPERLY COMPLETE THESE TASKS. SOME OF EVO MFG PRODUCTS MAY REQUIRE TWO OR MORE PEOPLE TO INSTALL SAFELY AND CORRECTLY. DO NOT ATTEMPT ALONE, ALWAYS ENLIST THE HELP OF TRAINED PROFESSIONAL WHEN NEEDED.**

**Notes: Set Up Before installation**

**This is a general instruction for this component kit.**

**Directions/pictures may vary for each specific install, use for reference only.**

**Keep all mounting bolts loose (installed but not torqued) we will torque later at the end of complete installation**

**Do not remove more than two control arms at a time**

**FRONT LOWER JL ENFORCER ARM STARTING LEGNTH CENTER TO CENTER, 24 1/8"**

**FRONT UPPER JL ENFORCER ARM STARTING LEGNTH CENTER TO CENTER, 20 1/4"**

**REAR LOWER JL ENFORCER ARM STARTING LEGNTH CENTER TO CENTER, 19 3/4"**

**REAR UPPER JL ENFORCER ARM STARTING LEGNTH CENTER TO CENTER, 17 1/2"**

**READ BEFORE INSTALL:**

ALL measurements stated above are starting points only, every vehicle is different. Professional alignment is recommended.

It is generally a good idea to apply Loctite to all threaded bolts.

ALWAYS wear safety glasses and other approved safety gear when working on a vehicle.

All supplied bolts torqued according to chart at end of instruction.

It is recommended all installation be performed by a trained professional. Some modification may have to be done.

Paint all unfinished surfaces after install is complete.



Parts included: Table below shows JL/JT Control Arms.

Description	#	Part #	Quantity
Jl Rear Lower Adj Control Arms	1	1174B	2
JL Rear Upper Adj Control Arms	2	1175B	2
JL/JT Front Lower Control Arms	3	3006B	2
JL/JT Front Upper Control Arms	4	3007B	2
JT Rear Adj Upper Control Arms	5	3081B	2
JT Rear Adj Lower Control Arms	6	3082B	2

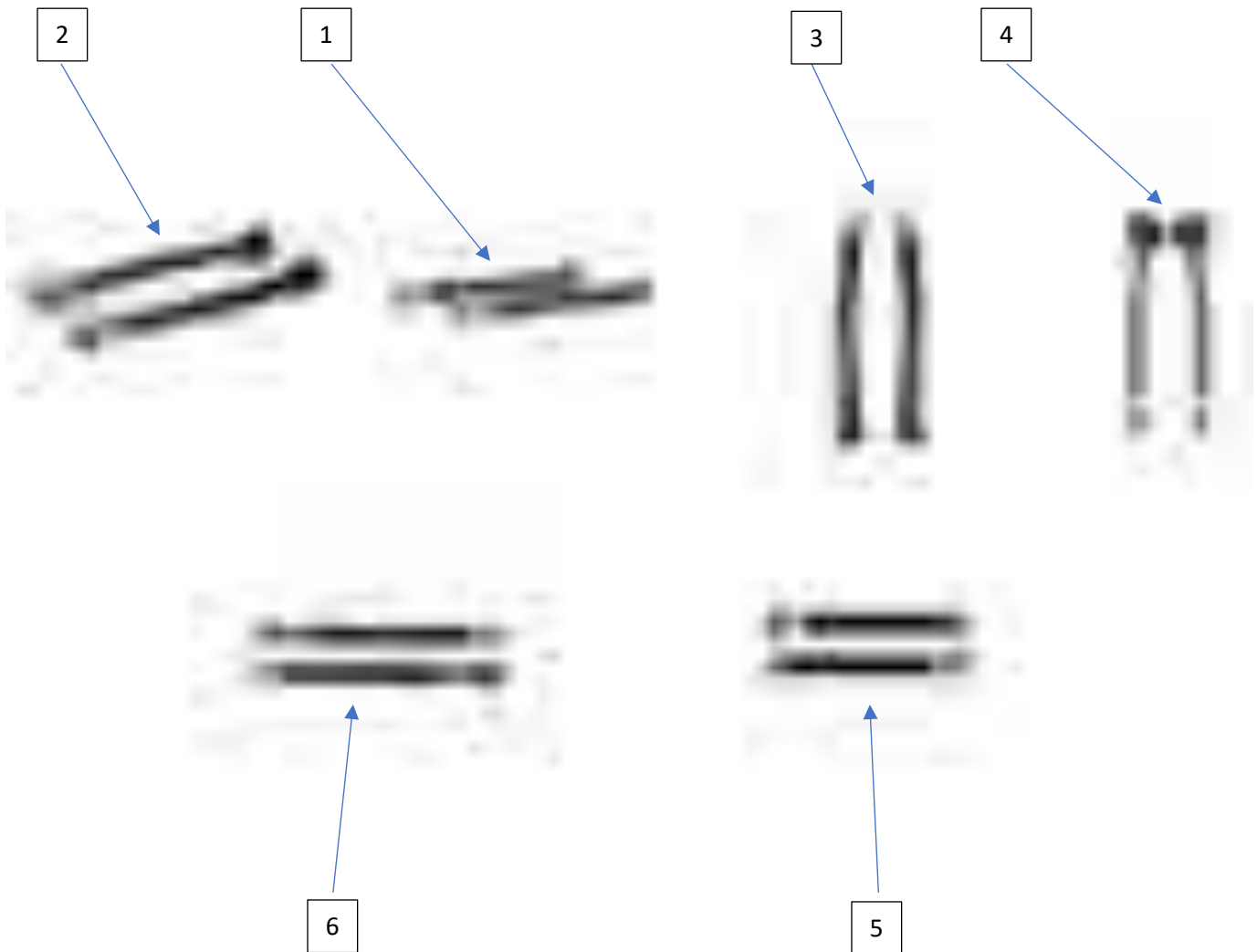



#### **Recommended Tools:**

- Standard socket set w/ wrench
  - OR Standard wrench set
- 



#### **Safety Steps for installation**

- For installing EVO MFG products always use wheel chokes to block rear tires from rolling.
  - Always make sure you have everything necessary ready before install.
  - If you have to, carefully lift front of vehicle by front frame rails extending suspension until tires leave the ground, place frame on approved jack stands for vehicle. Verify all lines/wires are not over extended.
  - Remove tires if needed for easier install.
  - Make sure to wear safety equipment (eye protection, hand protection, foot protection etc.) at all times during installation.
  - Make sure all safety precautions have been taken.
  - Always check and replace any part of vehicle that is worn or broken before starting install.
  - Do not mix anything EVO with weaker alternatives.
  - It is generally a good idea to apply liquid threadlock to all bolts.
  - Tighten included hardware to torque specifications in bottom table unless it is otherwise specified, factory bolts should be torqued to factory Jeep specifications.
- 





**After alignment is complete and no additional adjustments are to be made to control arms. Torque all 1" Jam Nuts to 250 ft/lbs and all 1-1/4" Jam Nuts torque to 300 ft/lbs. Regularly check all jam nuts and punch bolts on all control arms for proper torque/tightness. Failure to do so may cause premature wear of threads on arms.**

For front upper control arms:

1. Disconnect push-in clip from front upper control arm mounts at axle holding wire.

For all other arms:

2. Remove and replace one arm at a time. Keep bolts loose (installed but un-torqued) as described above. We will torque later in the installation process.

Use pictures as reference.



3. Make sure zerk fittings are facing up and at adjustable end at axle.
4. Adjustable end of control arms should be on the axle side.
5. Reuse factory hardware to mount EVO MFG control arms.

Note: For front upper control arms, bend in arm should face down.

Use pictures as reference.







Set pinion angle on vehicle so that the driveshaft and the pinion are inline with the axle at an approximate right height and centered to vehicle.

---



---

After Install:

- Tighten all bolts securing purchased parts to specified locations.
- After completing installation using provided instructions, go through all steps again to make sure nothing was missed, not tightened or improperly assembled.
- Some components may need to be purchased separately.
- Check turn signals, headlights, fog lights (if applicable), taillights, blinkers and windshield wipers.
- Adjust mirrors, speedometer and headlights if needed.
- Make sure all gauges are fully operational.
- Drive the vehicle slowly for a couple minutes, looking and listening for abnormal noises while driving. After modification of a vehicle there will be differences in driving experiences and capabilities, be mindful of that.
- Inspect and Retorque all Bolts after 500 miles of completed installation and regularly thereafter.
- Some modification may be required.



Recommended Torque:

Size	Grade 2		Grade 5		Grade 8		18-8 S/S	
	Coarse	Fine	Coarse	Fine	Coarse	Fine	Coarse	Fine
<b>#4*</b>	-	-	-	-	-	-	5.2	-
<b>#6*</b>	-	-	-	-	-	-	9.6	-
<b>#8*</b>	-	-	-	-	-	-	19.8	-
<b>#10*</b>	-	-	-	-	-	-	22.8	31.7
<b>1/4</b>	4	4.7	6.3	7.3	9	10	6.3	7.8
<b>5/16</b>	8	9	13	14	18	20	11	11.8
<b>3/8</b>	15	17	23	26	33	37	20	22
<b>7/16</b>	24	27	37	41	52	58	31	33
<b>1/2</b>	37	41	57	64	80	90	43	45
<b>9/16</b>	53	59	82	91	115	129	57	63
<b>5/8</b>	73	83	112	128	159	180	93	104
<b>3/4</b>	125	138	200	223	282	315	128	124
<b>7/8</b>	129	144	322	355	454	501	194	193
<b>1†</b>	188	210	483	541	682	764	287	289



EVO Manufacturing

Jeep Wrangler JL/JT Gladiator

JL/JT Control Arms

EVO- 3082B, 3081B, 3007B, 3006B, 1175B, 1174B





Before starting installation procedure please read <http://evomfg.com>Returns-Warranties-Shipping>

**CAREFULLY READ AND FOLLOW ALL INSTRUCTIONS IN THIS MANUAL AND KEEP FOR FUTURE REFERENCE. IF YOU HAVE ANY QUESTIONS ABOUT THE PRODUCT CALL EVO MANUFACTURING. FAILURE TO FOLLOW GUIDELINES COULD RESULT IN MALFUNCTION OF PARTS OR INJURY. PLEASE HAVE A TRAINED PROFESSIONAL ASSIST WITH OR INSTALL ALL PRODUCTS. INSTALLING EVO MFG PRODUCTS OR KITS DEMANDS SPECIFIC KNOWLEDGE, TOOLS AND EXPERIENCE. GENERAL KNOWLEDGE OF HOW TO USE LATER SPECIFIED TOOLS AND/OR LIMITED EXPERIENCE WITH EVO MFG PRODUCTS MAY NOT BE ENOUGH TO PROPERLY COMPLETE THESE TASKS. SOME OF EVO MFG PRODUCTS MAY REQUIRE TWO OR MORE PEOPLE TO INSTALL SAFELY AND CORRECTLY. DO NOT ATTEMPT ALONE, ALWAYS ENLIST THE HELP OF TRAINED PROFESSIONAL WHEN NEEDED.**

**Notes: Set Up Before installation**

**This is a general instruction for this component kit.**

**Directions/pictures may vary for each specific install, use for reference only.**

**Keep all mounting bolts loose (installed but not torqued) we will torque later at the end of complete installation**

**Do not remove more than two control arms at a time**

**FRONT LOWER JL ENFORCER ARM STARTING LEGNTH CENTER TO CENTER, 24 1/8"**

**FRONT UPPER JL ENFORCER ARM STARTING LEGNTH CENTER TO CENTER, 20 1/4"**

**REAR LOWER JL ENFORCER ARM STARTING LEGNTH CENTER TO CENTER, 19 3/4"**

**REAR UPPER JL ENFORCER ARM STARTING LEGNTH CENTER TO CENTER, 17 1/2"**

**READ BEFORE INSTALL:**

ALL measurements stated above are starting points only, every vehicle is different. Professional alignment is recommended.

It is generally a good idea to apply Loctite to all threaded bolts.

ALWAYS wear safety glasses and other approved safety gear when working on a vehicle.

All supplied bolts torqued according to chart at end of instruction.

It is recommended all installation be performed by a trained professional. Some modification may have to be done.

Paint all unfinished surfaces after install is complete.



Parts included: Table below shows JL/JT Control Arms.

Description	#	Part #	Quantity
Jl Rear Lower Adj Control Arms	1	1174B	2
JL Rear Upper Adj Control Arms	2	1175B	2
JL/JT Front Lower Control Arms	3	3006B	2
JL/JT Front Upper Control Arms	4	3007B	2
JT Rear Adj Upper Control Arms	5	3081B	2
JT Rear Adj Lower Control Arms	6	3082B	2

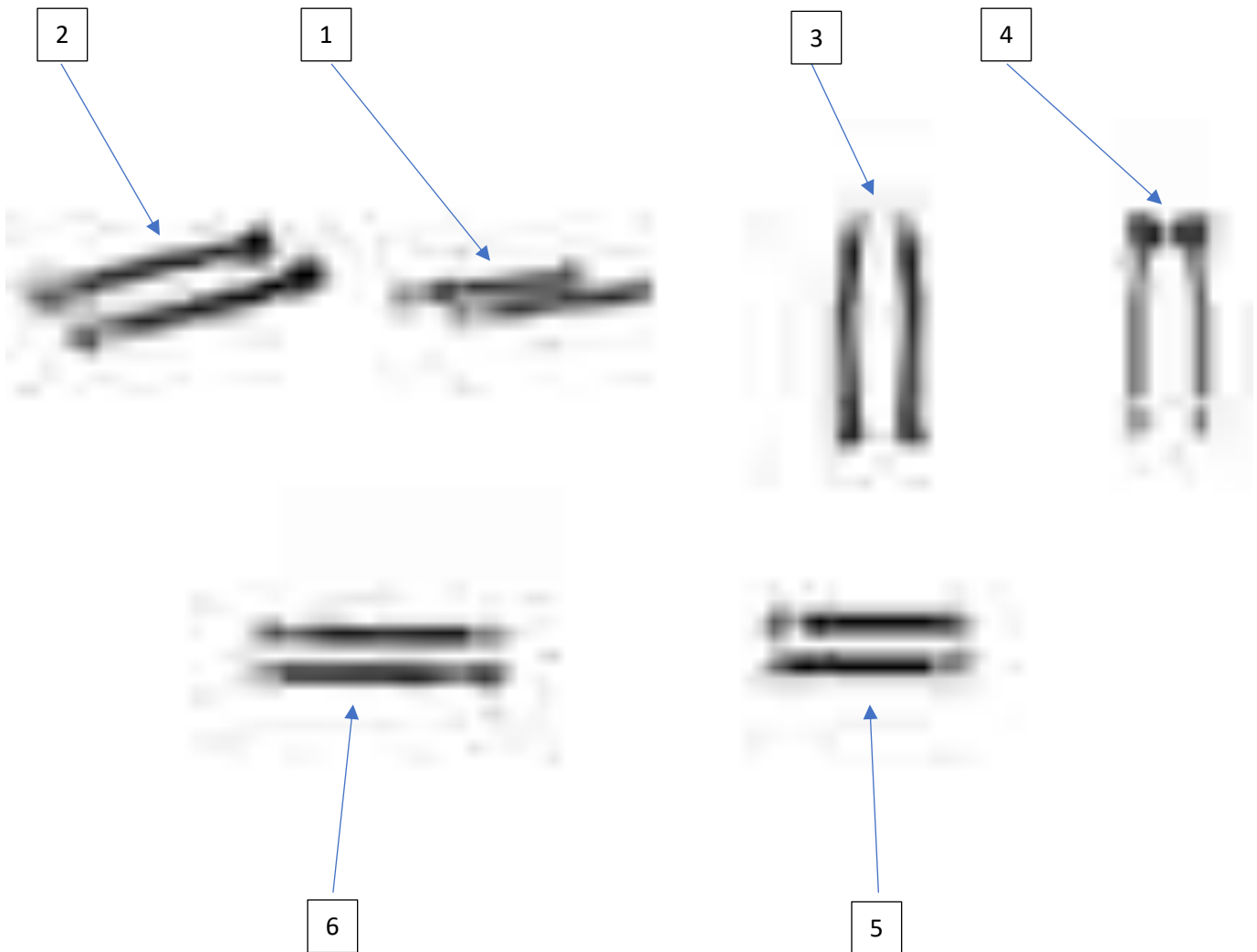



#### **Recommended Tools:**

- Standard socket set w/ wrench
  - OR Standard wrench set
- 



#### **Safety Steps for installation**

- For installing EVO MFG products always use wheel chokes to block rear tires from rolling.
  - Always make sure you have everything necessary ready before install.
  - If you have to, carefully lift front of vehicle by front frame rails extending suspension until tires leave the ground, place frame on approved jack stands for vehicle. Verify all lines/wires are not over extended.
  - Remove tires if needed for easier install.
  - Make sure to wear safety equipment (eye protection, hand protection, foot protection etc.) at all times during installation.
  - Make sure all safety precautions have been taken.
  - Always check and replace any part of vehicle that is worn or broken before starting install.
  - Do not mix anything EVO with weaker alternatives.
  - It is generally a good idea to apply liquid threadlock to all bolts.
  - Tighten included hardware to torque specifications in bottom table unless it is otherwise specified, factory bolts should be torqued to factory Jeep specifications.
- 





After alignment is complete and no additional adjustments are to be made to control arms. Torque all 1" Jam Nuts to 250 ft/lbs and all 1-1/4" Jam Nuts torque to 300 ft/lbs. Regularly check all jam nuts and punch bolts on all control arms for proper torque/tightness. Failure to do so may cause premature wear of threads on arms.

For front upper control arms:

1. Disconnect push-in clip from front upper control arm mounts at axle holding wire.

For all other arms:

2. Remove and replace one arm at a time. Keep bolts loose (installed but un-torqued) as described above. We will torque later in the installation process.

Use pictures as reference.



3. Make sure zerk fittings are facing up and at adjustable end at axle.
4. Adjustable end of control arms should be on the axle side.
5. Reuse factory hardware to mount EVO MFG control arms.

Note: For front upper control arms, bend in arm should face down.

Use pictures as reference.





Set pinion angle on vehicle so that the driveshaft and the pinion are inline with the axle at an approximate right height and centered to vehicle.

---



---

#### After Install:

- Tighten all bolts securing purchased parts to specified locations.
- After completing installation using provided instructions, go through all steps again to make sure nothing was missed, not tightened or improperly assembled.
- Some components may need to be purchased separately.
- Check turn signals, headlights, fog lights (if applicable), taillights, blinkers and windshield wipers.
- Adjust mirrors, speedometer and headlights if needed.
- Make sure all gauges are fully operational.
- Drive the vehicle slowly for a couple minutes, looking and listening for abnormal noises while driving. After modification of a vehicle there will be differences in driving experiences and capabilities, be mindful of that.
- Inspect and Retorque all Bolts after 500 miles of completed installation and regularly thereafter.
- Some modification may be required.





Recommended Torque:

Size	Grade 2		Grade 5		Grade 8		18-8 S/S	
	Coarse	Fine	Coarse	Fine	Coarse	Fine	Coarse	Fine
<b>#4*</b>	-	-	-	-	-	-	5.2	-
<b>#6*</b>	-	-	-	-	-	-	9.6	-
<b>#8*</b>	-	-	-	-	-	-	19.8	-
<b>#10*</b>	-	-	-	-	-	-	22.8	31.7
<b>1/4</b>	4	4.7	6.3	7.3	9	10	6.3	7.8
<b>5/16</b>	8	9	13	14	18	20	11	11.8
<b>3/8</b>	15	17	23	26	33	37	20	22
<b>7/16</b>	24	27	37	41	52	58	31	33
<b>1/2</b>	37	41	57	64	80	90	43	45
<b>9/16</b>	53	59	82	91	115	129	57	63
<b>5/8</b>	73	83	112	128	159	180	93	104
<b>3/4</b>	125	138	200	223	282	315	128	124
<b>7/8</b>	129	144	322	355	454	501	194	193
<b>1†</b>	188	210	483	541	682	764	287	289



## **EVO-1196B JK Rear Protek Shock Skids**



### **Bill of Materials**

**EVO-12264B Driver Rear Protek Shock Skid, Black qty 1**

**EVO-12265B Pass Rear Protek Shock Skid, Black qty 1**

### **Notes:**

Some grinding/cleanup or reshaping of the factory control arm mount may be required to slide skid over, Especially but not limited to mounts that have been used off road. Clean up all frayed damaged metal edges with grinding and hammering before installation. Test fit and adjust factory mount as needed. Use of aftermarket trackbar bracket that utilizes driver side lower rear control arm bolt will need to be adjusted to work with the EVO Protek Rear Shock Skids, or removed and install the EVO-1072B which requires no modifications to work with the EVO 1196B and is bolt on.

1. With vehicle safely parked and tires chalked on level ground,  
And with lower factory rear control/shock mount cleaned of all irregularities and or damage. On driver side remove the factory control arm and shock bolt at the axle.
2. Slide EVO Driver side skid of factory control arm mount. (If mount is tight, adjust/grind/hammer factory mount until mount passes into place).
3. Reinstall both factory control arm and shock bolts.
4. Tighten to factory specifications.
5. Repeat above on passenger side.





EVO-1197/1198/1199

## EVO JK Front Vented Inner Fenders



**Note:** This installation process will vary with aftermarket fenders. What is shown in these instructions is how to install with factory fenders. If installing with aftermarket fenders work around these steps to install. When installing inner fenders with aftermarket fenders. Inner fenders must mount to all body connections directly and then install all other fender parts or supports to the inner fender section. Sandwiching inner fenders between. Do not mount inner fenders to outside of other parts. Removal of factory fenders can damage factory fender clips. If so these can be purchased through dealerships for replacements if needed or traditional rivets can be used in replacement. When installing with aftermarket brakeline configurations, some adjustments may be needed to fit liner properly. Do so with great care. Fit product prior to painting.

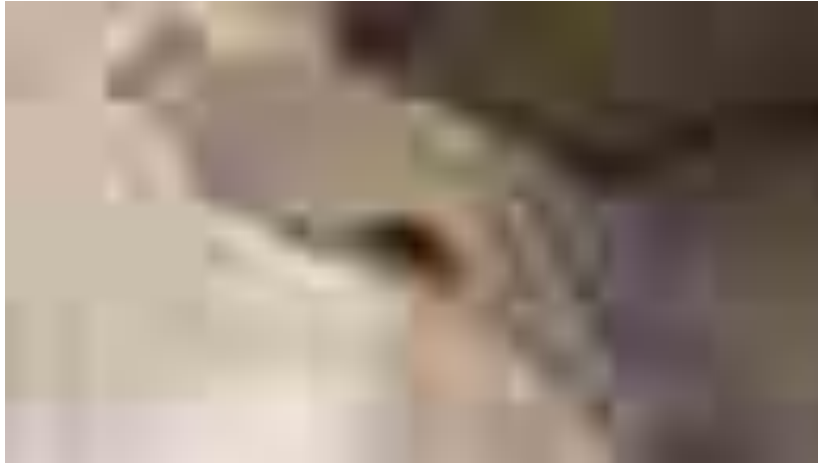

1. Assemble Inner fender parts on table prior to install. Use supplied #10 x 1/2" bolts and nylock nuts. Each inner fender is comprised of 3 main pieces (front middle rear) and 2 perforated vents (DTD Version is one piece with 2 vents, for this use supplied hardware to directly mount vents to back side of each liner). During assembly of liner, front and rear piece must be mounted on outside of inner piece. At this connection of parts, the



perforated piece both front and back should be bolted to back side of the inner piece. See image.

Drive side pieces are etched with an even part number. Passenger side pieces are etched with an odd part number. Tighten all bolts

2. Safely park and chalk vehicle on level ground with parking brake on.
3. Start on driver side. To remove your front factory fenders, begin by drilling out the 3 plastic rivets at the rear of the fender and removing them. Use a 3/16" drill bit for these.
4. Remove the panel clips using a panel clip tool or similar tool. There are a total of 4 clips.
5. Using a 10mm wrench remove the 5 bolts holding the fender in place. Save these bolts for reuse later.



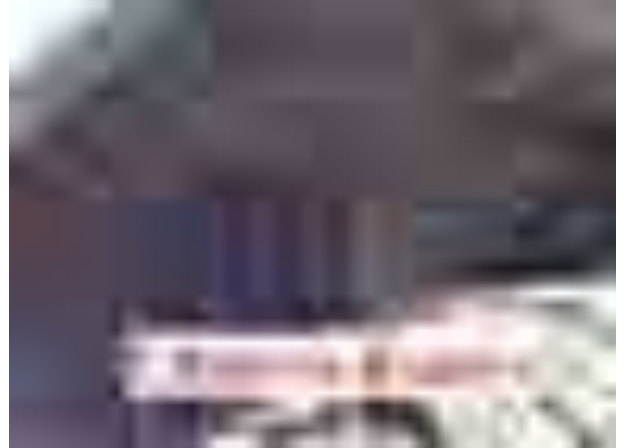

6. You should now be able to work your inner fender out of the wheel well.



7. With the inner fender removed, the rest of the fender will snap out.

8. The clips that held the fender in place can be removed by squeezing the inside of the clip together, as shown, from the inside of the body sheet metal.



9. With the factory fender removed.. The factory inner fender shell will need to be trimmed to reinstall. On the factory inner fender support where it meets/mounts to the body. Measure from the outside edge of the 3 holes  $\frac{1}{2}$ " and mark. Connect the 3 dots across the entire support edge as shown.
- 10.
- 11.Using safety glass during all cutting and drilling use a cutting tool and carefully cut the outside of the plastic at the marked line.
12. Insert EVO inner fender into the wheel opening.
- 13.Loosely insert supplied 5/16" bolt into inner fender and hole in inner body substructure. Just behind headlight.
- 14.Loosely install 2 bolts at upper sub structure that hold inner fender in place without factory fender. Snug these bolts.
- 15.At rear there are 2 holes in inner fender that fit top body inner structure. With inner liner in place and located to your liking. Using a drill with socket and extension, send 2 supplied self-tapping screws into body sheet metal at these 2 hole locations. Do not over tighten. Just a light snug is sufficient.
16. Now remove the 2 upper bolts at body substructure. Reinstall factory fender in factory location with the upper 2 bolt lip of EVO liner between fender and body substructure.
- 17.Tighten all bolts. Repeat above on passenger side.



EVO-1197/1198/1199

## EVO JK Front Vented Inner Fenders



**Note:** This installation process will vary with aftermarket fenders. What is shown in these instructions is how to install with factory fenders. If installing with aftermarket fenders work around these steps to install. When installing inner fenders with aftermarket fenders. Inner fenders must mount to all body connections directly and then install all other fender parts or supports to the inner fender section. Sandwiching inner fenders between. Do not mount inner fenders to outside of other parts. Removal of factory fenders can damage factory fender clips. If so these can be purchased through dealerships for replacements if needed or traditional rivets can be used in replacement. When installing with aftermarket brakeline configurations, some adjustments may be needed to fit liner properly. Do so with great care. Fit product prior to painting.





1. Assemble Inner fender parts on table prior to install. Use supplied #10 x 1/2" bolts and nylock nuts. Each inner fender is comprised of 3 main pieces (front middle rear) and 2 perforated vents (DTD Version is one piece with 2 vents, for this use supplied hardware to directly mount vents to back side of each liner). During assembly of liner, front and rear piece must be mounted on outside of inner piece. At this connection of parts, the



perforated piece both front and back should be bolted to back side of the inner piece. See image.

Drive side pieces are etched with an even part number. Passenger side pieces are etched with an odd part number. Tighten all bolts

2. Safely park and chalk vehicle on level ground with parking brake on.
3. Start on driver side. To remove your front factory fenders, begin by drilling out the 3 plastic rivets at the rear of the fender and removing them. Use a 3/16" drill bit for these.
4. Remove the panel clips using a panel clip tool or similar tool. There are a total of 4 clips.
5. Using a 10mm wrench remove the 5 bolts holding the fender in place. Save these bolts for reuse later.



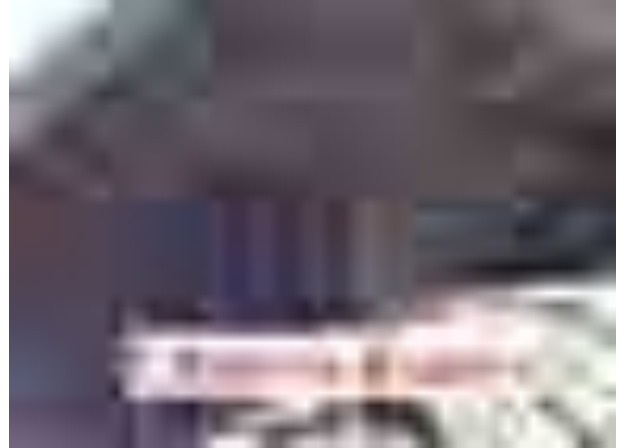

6. You should now be able to work your inner fender out of the wheel well.



7. With the inner fender removed, the rest of the fender will snap out.

8. The clips that held the fender in place can be removed by squeezing the inside of the clip together, as shown, from the inside of the body sheet metal.



9. With the factory fender removed.. The factory inner fender shell will need to be trimmed to reinstall. On the factory inner fender support where it meets/mounts to the body. Measure from the outside edge of the 3 holes  $\frac{1}{2}$ " and mark. Connect the 3 dots across the entire support edge as shown.
- 10.
- 11.Using safety glass during all cutting and drilling use a cutting tool and carefully cut the outside of the plastic at the marked line.
12. Insert EVO inner fender into the wheel opening.
- 13.Loosely insert supplied 5/16" bolt into inner fender and hole in inner body substructure. Just behind headlight.
- 14.Loosely install 2 bolts at upper sub structure that hold inner fender in place without factory fender. Snug these bolts.
- 15.At rear there are 2 holes in inner fender that fit top body inner structure. With inner liner in place and located to your liking. Using a drill with socket and extension, send 2 supplied self-tapping screws into body sheet metal at these 2 hole locations. Do not over tighten. Just a light snug is sufficient.
16. Now remove the 2 upper bolts at body substructure. Reinstall factory fender in factory location with the upper 2 bolt lip of EVO liner between fender and body substructure.
- 17.Tighten all bolts. Repeat above on passenger side.



EVO-1197/1198/1199

## EVO JK Front Vented Inner Fenders



**Note:** This installation process will vary with aftermarket fenders. What is shown in these instructions is how to install with factory fenders. If installing with aftermarket fenders work around these steps to install. When installing inner fenders with aftermarket fenders. Inner fenders must mount to all body connections directly and then install all other fender parts or supports to the inner fender section. Sandwiching inner fenders between. Do not mount inner fenders to outside of other parts. Removal of factory fenders can damage factory fender clips. If so these can be purchased through dealerships for replacements if needed or traditional rivets can be used in replacement. When installing with aftermarket brakeline configurations, some adjustments may be needed to fit liner properly. Do so with great care. Fit product prior to painting.

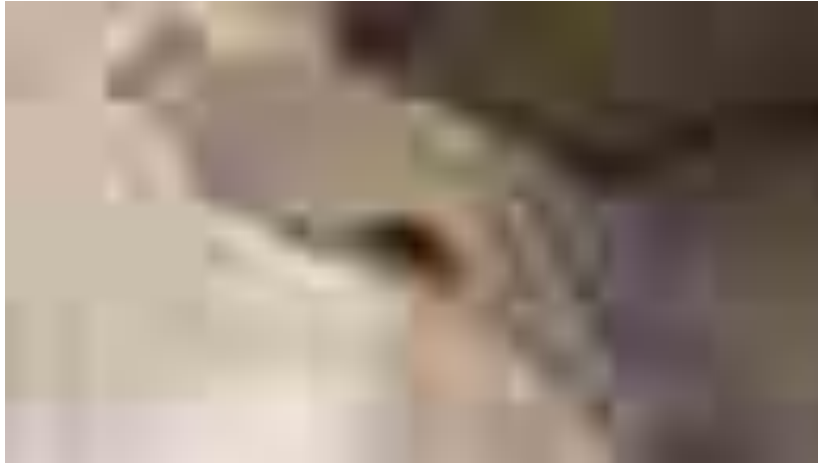

1. Assemble Inner fender parts on table prior to install. Use supplied #10 x 1/2" bolts and nylock nuts. Each inner fender is comprised of 3 main pieces (front middle rear) and 2 perforated vents (DTD Version is one piece with 2 vents, for this use supplied hardware to directly mount vents to back side of each liner). During assembly of liner, front and rear piece must be mounted on outside of inner piece. At this connection of parts, the



perforated piece both front and back should be bolted to back side of the inner piece. See image.

Drive side pieces are etched with an even part number. Passenger side pieces are etched with an odd part number. Tighten all bolts

2. Safely park and chalk vehicle on level ground with parking brake on.
3. Start on driver side. To remove your front factory fenders, begin by drilling out the 3 plastic rivets at the rear of the fender and removing them. Use a 3/16" drill bit for these.
4. Remove the panel clips using a panel clip tool or similar tool. There are a total of 4 clips.
5. Using a 10mm wrench remove the 5 bolts holding the fender in place. Save these bolts for reuse later.



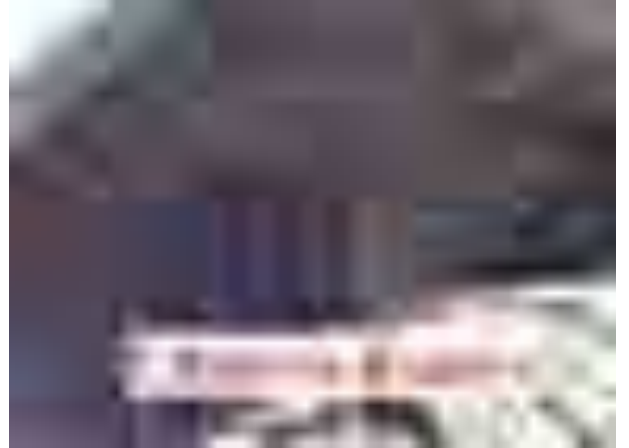

6. You should now be able to work your inner fender out of the wheel well.



7. With the inner fender removed, the rest of the fender will snap out.

8. The clips that held the fender in place can be removed by squeezing the inside of the clip together, as shown, from the inside of the body sheet metal.



9. With the factory fender removed.. The factory inner fender shell will need to be trimmed to reinstall. On the factory inner fender support where it meets/mounts to the body. Measure from the outside edge of the 3 holes  $\frac{1}{2}$ " and mark. Connect the 3 dots across the entire support edge as shown.
- 10.
- 11.Using safety glass during all cutting and drilling use a cutting tool and carefully cut the outside of the plastic at the marked line.
12. Insert EVO inner fender into the wheel opening.
- 13.Loosely insert supplied 5/16" bolt into inner fender and hole in inner body substructure. Just behind headlight.
- 14.Loosely install 2 bolts at upper sub structure that hold inner fender in place without factory fender. Snug these bolts.
- 15.At rear there are 2 holes in inner fender that fit top body inner structure. With inner liner in place and located to your liking. Using a drill with socket and extension, send 2 supplied self-tapping screws into body sheet metal at these 2 hole locations. Do not over tighten. Just a light snug is sufficient.
16. Now remove the 2 upper bolts at body substructure. Reinstall factory fender in factory location with the upper 2 bolt lip of EVO liner between fender and body substructure.
- 17.Tighten all bolts. Repeat above on passenger side.



EVO Manufacturing

Jeep Wrangler JK/JKU

JK High Clearance Long Arm Kit

EVO- 1050, EVO-1200







Before starting installation procedure please read <http://evomfg.com>Returns-Warranties-Shipping>

**CAREFULLY READ AND FOLLOW ALL INSTRUCTIONS IN THIS MANUAL AND KEEP FOR FUTURE REFERENCE. IF YOU HAVE ANY QUESTIONS ABOUT THE PRODUCT CALL EVO MANUFACTURING. FAILURE TO FOLLOW GUIDELINES COULD RESULT IN MALFUNCTION OF PARTS OR INJURY. PLEASE HAVE A TRAINED PROFESSIONAL ASSIST WITH OR INSTALL ALL PRODUCTS. INSTALLING EVO MFG PRODUCTS OR KITS DEMANDS SPECIFIC KNOWLEDGE, TOOLS AND EXPERIENCE. GENERAL KNOWLEDGE OF HOW TO USE LATER SPECIFIED TOOLS AND/OR LIMITED EXPERIENCE WITH EVO MFG PRODUCTS MAY NOT BE ENOUGH TO PROPERLY COMPLETE THESE TASKS. SOME OF EVO MFG PRODUCTS MAY REQUIRE TWO OR MORE PEOPLE TO INSTALL SAFELY AND CORRECTLY. DO NOT ATTEMPT ALONE, ALWAYS ENLIST THE HELP OF TRAINED PROFESSIONAL WHEN NEEDED.**

**Notes: Set Up Before installation**

**All Vehicles that spend time on salted roads. It is recommended that removal of both threaded collar and joint on all arms. Apply a small amount of Anti Seize on threads and reassemble.**

**Keep all mounting bolts loose (installed but not torqued) we will torque later at the end of complete installation**

After alignment is complete and no additional adjustments are to be made to control arms. Torque all 1" Jam Nuts to 250 ft/lbs and all 1-1/4" Jam Nuts torque to 300 ft/lbs. Regularly check all jam nuts and punch bolts on all control arms for proper torque/tightness. Failure to do so may cause premature wear of threads on arms.

**READ BEFORE INSTALL:**

2010 and newer JK requires exhaust modifications. 2012 or Newer: Exhaust modifications required on front exhaust loop.

It is generally a good idea to apply Loctite to all threaded bolts.

ALWAYS wear safety glasses and other approved safety gear when working on a vehicle.

All supplied bolts torqued according to chart at end of instruction.

It is recommended all installation be performed by a trained professional. Some modification may have to be done.

Paint all unfinished surfaces after install is complete.



Parts included: Table below shows JK High Clearance Long Arm Kit.

Description	#	Part #	Quantity
Front Lower Arms	1	EVO-11060B	2
Rear Lower Arms	2	EVO-11061B	2
Rear Upper LA Driver	3	EVO-11035B	1
Rear Upper LA Passenger	4	EVO-11036B	1
Front Upper LA Driver	5	EVO-11037B	1
Front Upper LA Passenger	6	EVO-11038B	1
Rear Driver LA Control Arm Bracket	7	EVO-11047	1
Rear Passenger LA Control Arm Bracket	8	EVO-11048	1
Driver Front LA Control Arm Bracket	9	EVO-11049	1
Passenger Front LA Control Arm Bracket	10	EVO-11050	1
3 Degree Axle Mount	11	EVO-1045	1
Shock Tab, Cantilever Sub Frame	12	EVO-10003-7	4
LA Upgrade Hardware Pack	13	EVO-770024	1
Misalignment Spacer	14	EVO-100563263	4
JK Rear Upper Bolt Tab	15	EVO-11005CZ	2
JK Rear Lower Bolt Tab	16	EVO-11006CZ	2
HHCS 3/8-24x1.50 GrC Zink	17	EVO-900023	8
Stover Lock Nut 3/8-24 GrC Zinc	18	EVO-900221	8
Black Internal Retain	29	EVO-900286	2
HHCS M12, 130mm, 1.75mm, Partial Thread	20	EVO-900325	4
Driver HC Main Bracket	21	EVO-12391-1	1
Passenger HC Main Bracket	22	EVO-12392-1	1
Shock Mount Backing Plate	23	EVO-12391-2	2
Swaybar Mount Plate	24	EVO-12391-4	2
Driver Shock Mounting Bracket	25	EVO-12391-3	1
Passenger Shock Mounting Bracket	26	EVO-12392-3	1





#### **Recommended Tools:**

- Impact with standard sockets
  - Sawzall/Cut off wheel or similar
  - Welder and Materials
  - Proper Safety Gear
- 



#### **Safety Steps for installation**

- For installing EVO MFG products always use wheel chokes to block rear tires from rolling.
  - Always make sure you have everything necessary ready before install.
  - If you have to, carefully lift front of vehicle by front frame rails extending suspension until tires leave the ground, place frame on approved jack stands for vehicle. Verify all lines/wires are not over extended.
  - Remove tires if needed for easier install.
  - Make sure to wear safety equipment (eye protection, hand protection, foot protection etc.) at all times during installation.
  - Make sure all safety precautions have been taken.
  - Always check and replace any part of vehicle that is worn or broken before starting install.
  - Do not mix anything EVO with weaker alternatives.
  - It is generally a good idea to apply liquid threadlock to all bolts.
  - Tighten included hardware to torque specifications in bottom table unless it is otherwise specified, factory bolts should be torqued to factory Jeep specifications.
- 





With Jeep parked on flat surface, wheel chalked and in park.

1. Support axle with adjustable jacks,  
Remove shocks.
- 





2. Remove all control arms.

Be careful, axle might shift once all arms are removed.

---



3. Remove brake line brackets

---





4. Lower axle carefully until springs can be removed.
- 



---

## **FRONT INSTALL**

5. Mark and cut front factory control arm brackets as shown on lines in photos. Lower front factory brackets need to be trimmed as shown leaving the outer factory portion of the bracket remaining on the vehicle.
- 

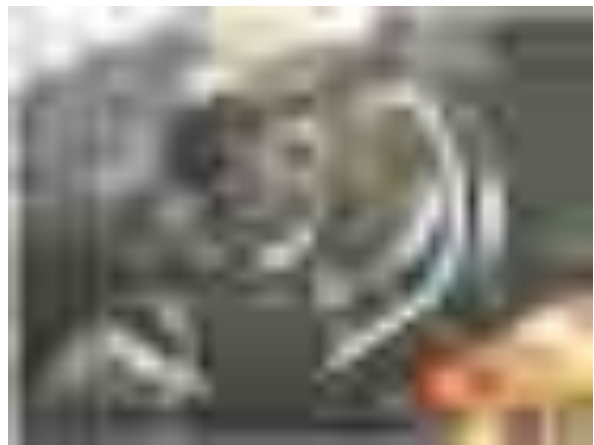



6. Support transmission cross-member with adjustable jack stand. Remove two bolts on passenger side that hold in cross-member.
  7. Install front passenger side brackets as shown.
  8. Reinstall transmission bolts just as factory through new front control arm brackets
  9. Install supplied  $\frac{1}{2}$ " bolt at factory lower control arm tab toward front of vehicle.
- 



10. Drill  $\frac{3}{8}$ " hole in front side of factory transmission cross-member
11. Through access hole on underside of cross-member install  $\frac{3}{8}$ " bolt, nut and washer through supplied control arm bracket to transmission cross-member.

Repeat steps on driver side.

12. Weld all control arm brackets to frame in all locations they touch the frame top and bottom. DO NOT weld toward the center of bracket that touches the removable factory transmission crossmember.
- 







13. Install front control arms upper and lower using factory hardware on factory mounting locations and supplied hardware on EVO Brackets. Front lowers starting length 34.5" and upper starting length 26.375", roughly fully threaded in. FRONT UPPER ARMS SHOULD HAVE THE BEND OF THE ARM MOVING AWAY FROM THE FRAME ON BOTH DRIVER AND PASS SIDES.



14. Front upper control arm mounts at the frame will have the bolt inserted from the ground up. Not left to right.

---

## **REAR INSTALL**

After removing all control arms, brake line brackets and springs.

15. Remove all rear factory control arm brackets as shown in lines on photos. All rear control arm brackets need to be removed and grinded flush to the frame.

---





16. Carefully remove gas tank from vehicle. This can be heavy depending on fuel level. Be very careful as this contains highly flammable gasoline. Store in a safe place.

---



17. Cut rear body mount using line shown in photo. The rear most tab of the body mount needs to be trimmed all the way to the top. Grind all cuts smooth to frame.

---





18. Remove two factory body mount bolts.
  19. Install driver and pass side brackets on frame.
  20. Tighten the two body mount bolts to factory specifications.
  21. Mark center of all the two control arm holes, 9/16", and drill through outer frame side only.
- 



Driver side will need a square hole cut into frame (same as the hole on the frame on passenger side). This is for nut access for the driver side rear lower arms. Use bracket as template for cut. Use plasma cutter or drill corners of square with drill and complete the straights of the square with cut off wheel.





22. Reinstall brackets to body mounts if removed and weld all edges of the brackets completely to frame inside and out.

---



23. Reinstall gas tank to it factory location using factory hardware. Be extremely careful in doing so, no flames, sparks or cutting etc at this time.

24. Cut off rear lower control arm bracket on the axle and grind smooth to axle tube.

---





25. Install rear upper and lower control arms into all remaining control arm mounts on axle and frame. Rear lower mounts at axle will not exist at this time. Use small nut plate with bend for rear lower arm nuts at frame through the square holes and longer nut plates for rear upper nuts at frame through factory small square access hole on underside of frame.

---



26. Adjusts rear lower control arms to 30.5" from center to center and uppers to 20.5" center to center.

---





For EVOlever ONLY:

27. Install rear EVOlever axle bracket onto remaining control arm joints with factory hardware. Hold up to axle tube where control arm bracket once was.



28. With rear wheels and tires installed pivot lower control arm to axle tube and move outward on axle tube while radius on brackets are still around tube until the rear control arms and the inner sidewall of the tire are 1.0" apart. Tack new lower control arm mounts into place on axle tube. Roughly ends of brackets will be close the end flanges on the axle tube ends.
- 





29. If installing with EVOlever or rear DTD. There are 4 smaller tabs that will be used for the new limit strap location. 2 per strap, one on each side of strap tab. They should be installed and tacked into place in line with tabs on subframe above, straight off the back of the axle tube. When cycling later on, make sure shocks do not contact subframe at full droop/extension. If so, rotate tabs lower on axle tube and slightly inward until no contact is made of shocks to subframe.
- 



30. Thick rear swaybar tab should be installed on outside sheet metal edge of factory bumpstop pad and straight rearward of tube. Tack into place.
- 





31. If installing this kit with the EVO LEVER suspension then follow this step and skip the “If not installing EVOlever” steps.

32. The bracket should have the open side facing rear of vehicle and should sit on top of axle, inside where the limit strap bracket sits. (use picture as reference)

**Note: Every axle/EVOlever is specific to your vehicle setup, the above steps for placement are a starting point, adjust as necessary before welding and painting.**



If NOT installing EVOlever:

33. Assemble shock mount to the main axle bracket. Make sure shock mount is facing towards center of axle on both passenger and driver side.

**34. If using EVO MFG rear bolt on coilovers, shock mount tabs should be inserted in the upper cutouts in the main bracket.**







35. If using coilspring and shock then install shock mount tabs in the lower cutouts in the main bracket.

36. Tack in place, double check fitment and then weld shock mount bracket to main bracket.

---



37. Sway bar mount bracket should be welded to long cutout in main axle bracket. If shock mount is in the upper slot then trimming may be required to properly seat sway bar bracket.

---





38. Mate the rear backing plate to the main EVO MFG bracket by tack welding. Once properly placed, weld both brackets together.

---



39. Using the slot in the main axle bracket, key into the outermost part of the bump stop bracket. Once you find an acceptable fitment tack in place.

---



40. Weld on all axle brackets/tabs to axle once axle has been cycled up and down and verification is made that all components clear each other.



41. Once the bracket has been welded in place and painted then loosely install shock/Coilover using factory hardware if applicable.

Reinstall springs if reusing coilsprings.



42. Cycle front and rear suspension up and down while turning front tires left and right to verify no interference with any components and that all wires, hoses etc are clear and are long enough.





43. Set pinion angle on vehicle so that the driveshaft and the pinion are inline with the axle at an approximate right height and centered to vehicle.

---



44. Very carefully set vehicle back on ground.

45. Torque all suspension bolts to factory specifications including wheels.

2012 or Newer: Exhaust modifications required on front exhaust loop. Custom exhaust fabrication or below required. Exhaust loop needs to be cut perpendicular to floor straight through factory exhaust loop on both the forward side of the loop and rearward near coupling flange. The loop then needs to be flipped 180 so that the previous front is now welded to the rear and vice versa. Rotate and make sure loop clears front upper control arm bracket and arms before fully welding around to reconnect to exhaust system.

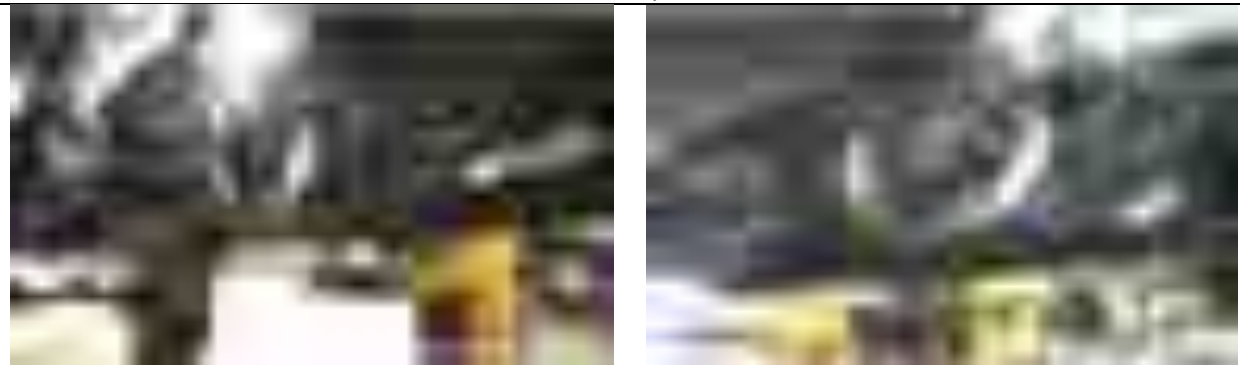



After Install:

- Tighten all bolts securing purchased parts to specified locations.
- After completing installation using provided instructions, go through all steps again to make sure nothing was missed, not tightened or improperly assembled.
- Some components may need to be purchased separately.
- Check turn signals, headlights, fog lights (if applicable), taillights, blinkers and windshield wipers.
- Adjust mirrors, speedometer and headlights if needed.
- Make sure all gauges are fully operational.
- Drive the vehicle slowly for a couple minutes, looking and listening for abnormal noises while driving. After modification of a vehicle there will be differences in driving experiences and capabilities, be mindful of that.
- Inspect and Retorque all Bolts after 500 miles of completed installation and regularly thereafter.
- Some modification may be required.

Recommended Torque:

Size	Grade 2		Grade 5		Grade 8		18-8 S/S	
	Coarse	Fine	Coarse	Fine	Coarse	Fine	Coarse	Fine
<b>#4*</b>	-	-	-	-	-	-	5.2	-
<b>#6*</b>	-	-	-	-	-	-	9.6	-
<b>#8*</b>	-	-	-	-	-	-	19.8	-
<b>#10*</b>	-	-	-	-	-	-	22.8	31.7
<b>1/4</b>	4	4.7	6.3	7.3	9	10	6.3	7.8
<b>5/16</b>	8	9	13	14	18	20	11	11.8
<b>3/8</b>	15	17	23	26	33	37	20	22
<b>7/16</b>	24	27	37	41	52	58	31	33
<b>1/2</b>	37	41	57	64	80	90	43	45
<b>9/16</b>	53	59	82	91	115	129	57	63
<b>5/8</b>	73	83	112	128	159	180	93	104
<b>3/4</b>	125	138	200	223	282	315	128	124
<b>7/8</b>	129	144	322	355	454	501	194	193
<b>1+</b>	188	210	483	541	682	764	287	289



EVO Manufacturing

2.5" Jeep Wrangler JL 2018+

Boost and Overland Boost Instruction Manual



Wheel spacers or aftermarket wheels with a smaller backspacing than factory (4.75" or smaller number is recommended) are required for a complete installation. If installing EVO MFG Enforcer Control Arms: All Vehicles that spend time on salted roads. It is recommended that removal of control arm joint (threaded one) on all control arms before installation of vehicle. Apply a small amount of Anti Seize on threads and reassemble. ALWAYS wear safety glasses and other approved safety gear when working on a vehicle. All factory bolts should be tightened to factory specifications. All supplied bolts torqued according to chart at end of instruction.

**After alignment is complete and no additional adjustments are to be made to control arms. Torque all 1" Jam Nuts to 250 ft/lbs and all 1-1/4" Jam Nuts torque to 300 ft/lbs. Regularly check all jam nuts and punch bolts on all control arms for proper torque/tightness. Failure to do so may cause premature wear of threads on arms.**

1. Safely and securely park vehicle on level ground with parking brake applied.
2. Use wheel chokes to block rear tires from rolling
3. Loosen all front and rear control arm and trackbar bolts at both axle and frame. DO NOT REMOVE (unless installing EVO Enforcer Arms). Just loosen a few turns to remove bolt compression on control arm bushings. If installing EVO Enforcer arms. Do so at this time. Remove and replace one arm at a time. **Keep bolts loose (installed but un-torqued) as described above. We will torque later at end of complete installation.**

FRONT LOWER JL ENFORCER ARM STARTING LEGNTH CENTER TO CENTER 24 1/8"

FRONT UPPER JL ENFORCER ARM STARTING LEGNTH CENTER TO CENTER 20 1/4"

REAR LOWER JL ENFORCER ARM STARTING LEGNTH CENTER TO CENTER 19 3/4"

REAR UPPER JL ENFORCER ARM STARTING LEGNTH CENTER TO CENTER 17 1/2"

## FRONT INSTALL

4. Carefully lift front of vehicle by front frame rails extending suspension until tires leave the ground.
5. Securely place weight approved jack stands for vehicle under frame.
6. With vehicle front tires now suspended and frame securely supported on stands, remove front tires from vehicle.
7. Remove bolt from driver and pass side brake line bracket at frame just behind front coils.
8. Remove both driver and passenger side swaybar links bolts at axle and swaybar removing swaybar links and rotate sway up and out of the way. Factory front links will not be reused.
9. Disconnect push-in clip from front upper control arm mounts at axle holding wire.
10. **Vehicle wiring and hoses vary, make sure all wires, hoses, lines etc from frame to axle are freed up giving ample length to move axle downward as needed before proceeding, verify wiring/hoses etc do not get stretched while lowering axle in next steps.**
11. Lightly jack front driver side axle tube slightly. With axle slightly supported remove front lower shock bolt from axle. Varying axle jack tension to the right amount will alleviate load on the bolt and allow it to freely slide out. If you are replacing shocks and not using shock extensions

remove upper bolt and remove shock. Otherwise leave shock mounted at upper. Support driver side axle with jack stand and repeat this step on passenger side.

12. Remove trackbar bolt at axle. This will allow the axle to move side to side so be cautious about this from here on.
13. Lower jack under axle giving room and remove front spring. Keep track of which spring is driver and passenger.
14. Insert driveside EVO coil spacer up into coil pocket around bump tube. Install supplied  $\frac{1}{4}$ " .75 bolt through rear back hole in frame coil seat and EVO coil mount. Tighten bolt to below chart at end of instruction.



15. Insert supplied  $\frac{3}{8}$  x 2" bolt into front bumpstop extension. Place bumpstop with bolt inside (bore side up) factory spring and reinstall factory coil spring and rubber isolator on top of coil into its original location on both the frame and axle. Isolator will now be seated on the EVO coil spacer. Axle may need to be lowered to install.

16. With spring in place and bumpstop extension sitting on axle pad and bolt inserted into bumpstop extension. Install supplied  $\frac{3}{8}$ " nut from under spring pad to bolt inserted inside bumpstop extension and tighten.



## OVERLAND KITS:



If you are installing Overland kit with Front Control Arm Relocation brackets. Follow these instruction: If not continue to next numbered step.

With axle and frame/vehicle safely supported. Loosen but do not remove bolt or nut on both upper and lower control bolts at their axle connections. Remove heat shield from upper control arm at frame and unbolt upper driver side upper control arm from frame. Unbolt lower control arm at frame **being very cautious and careful as the axle will no longer be connected to vehicle on the driver side at this time.** Rotate control arms out of the way and insert driver side control arm relocation brackets into frame pockets where control arms were once mounted. In both upper and lower arm location where bracket connects with frame insert supplied crush tube into gaps (shorter sleeve for upper mount and longer tube for lower mount). Use factory bolts to frame locations through EVO brackets and crush sleeves. Torque all frame bolts at EVO control arm brackets to factory specifications.

Rotate control arms back into their new location on the EVO Control arm relocation brackets. Use Supplied M12 bolt, washers and nut for upper control arm mount and 5/8 bolt, washers, nut for lower control arm mount.

17. Install front EVO brake line extension bracket at original brake line mounting location on frame with factory bolt.



18. Install factory brake line to the new lower location on the EVO brake line extension bracket. **Be very careful moving line into new location. The factory hardline will need to be slightly manipulated to be relocated. Do not use tools or pinch/crack the line.**

19. Reinstall shock at axle per factory specifications. If you are installing shock extensions. Do so at this time. Follow instructions for that kit. If you are installing new shocks, install shocks at both upper and lower mounting locations. Torque to factory specifications.

If new Lower EVO MFG Enforcer Arms have been installed. Carefully enlarge/drill brake line bracket mounting hole



that once attached to factory lower arm to ½" and install on shock bolt after shock bolts have been torqued. Use M12 nut supplied with EVO Enforcer Control Arms. Series: Shock nut, brake line bracket, Flange Nut.

20. Repeat steps 10-19 on passenger side including Overland kit section is applicable.
21. Reinstall wheel and torque to factory specifications.
22. Carefully lift vehicle by frame, remove jack stands and lower to ground. When lowering be mindful of the front trackbar at axle this is not bolted in. It will need to be guided into its bracket at the axle while lowering the vehicle. When on the ground carefully turn steering without ending running and in park with parking brake on and wheels chalked until trackbar lines up with hole in trackbar bracket. Insert factory bolt and loosely tighten bolt.
- 23. Torque all control arm bolts, uppers, lowers at frame and axle. Torque all shock bolts at frame and axle. Torque front trackbar bolt. Check and torque all other bolts. Use chart below for supplied hardware. Use factory specifications for factory hardware.**
24. Front swaybar links should be left uninstalled at this time. We will install factory rear swaybar links on the front later in the process.

## REAR Install

25. Safely and securely park vehicle on level ground with parking brake applied.
26. Use wheel chokes to block front tires from rolling
27. While safely parked on ground. Loosen all rear control arm and trackbar bolts at both axle and frame. DO NOT REMOVE (unless installing EVO Enforcer Arms). Just loosen a few turns to remove bolt compression on control arm bushings. If installing EVO Enforcer arms. Do so at this time. Remove and replace one arm at a time. Keep bolts loose (installed but un-torqued) as described above.
28. Carefully lift rear of vehicle by frame rails/crossmember extending suspension until tires leave the ground.
29. Securely place weight approved jack stands for vehicle under frame.
30. With vehicle rear tires now suspended and frame securely supported on stands, remove rear tires from vehicle.
31. Remove both driver and passenger side swaybar links bolts at axle and swaybar removing swaybar links and rotate sway up and out of the way.
- 32. Vehicle wiring and hoses vary, make sure all wires, hoses, lines etc from chassis to axle are freed up giving ample length to move axle downward as needed before proceeding, verify wiring/hoses etc do not get stretched while lowering axle in next steps.**



side

33. Lightly jack front driver side axle tube slightly. With axle slightly supported remove front lower shock bolt from axle. Varying axle jack tension to the right amount will alleviate load on the bolt and allow it to freely slide out. If you are replacing shocks and not using shock extensions remove upper bolt and remove shock. Otherwise leave shock mounted at upper. Support driver side axle with jack stand and repeat this step on passenger side.

34. Lower jack under axle giving room and remove rear springs. Keep note of which spring is driver and passenger.

35. Install rear bump stop extensions to axle pads on both passenger and driver side axle pads using supplied 5/16" x .75 bolts, washers and nuts.

36. Install EVO driver side coil spring spacer into upper coil pocket on frame using supplied 7/16" x 1 bolts, washers and nuts. Insert bolts from top down through frame then EVO bracket.

37. Repeat on passenger



38. Reinstall driver and passenger side coil springs into place keeping factory rubber isolator on top of spring. Be sure to align nub on isolator so that it inserts into hole in EVO brackets. The spring isolator will now be resting on the EVO coil spring spacer.
39. Assemble supplied rear swaybar links. Using light oil such as WD 40. Lubricate inner surface of link loops. Tap or vice in supplied rubber bushings. Lubricate inner surface of rubber bushings. Tap or vice in supplied swaybar tube sleeves.
40. With rear spring installed. Jack axle up until shock bolts line up with axle mounting holes. **Be very aware that vehicle does not lift off chassis/frame jack stands.** If you are installing new shocks or shock extensions, do so at this time. Follow factory torque specs for shockbolts.
41. Using 2 factory swaybar bolts and 2 supplied M12 x 60 bolts washers and nuts install assembled EVO swaybar links to axle on outside of swaybar tab and outside of swaybar itself (outside outside).
42. Reconnect all disconnected hoses, wires etc.
43. Reinstall rear wheels and torque to factory specs
44. Carefully jack vehicle by frame and remove jack stands.
45. Lower vehicle to ground.
46. Install factory rear swaybar link onto the front axle and front sway. Rubber bushing side on factory link goes inside the two tabs on the axle and stud mount to outside of swaybar. Bend in link should jog upwards moving studded end toward tire.
47. **Torque all control arm bolts, uppers, lowers at frame and axle. Torque all shock bolts at frame and axle. Torque front trackbar bolt. Check and torque all other bolts. Use chart below for supplied hardware. Use factory specifications for factory hardware.**

RECENTER STEERING WHEEL by Adjusting Turn buckle on Draglink. Make sure to turn the correct way to center (do not do a full rotation of steering wheel, closest direction to straight, watch wheel

while turning) and tighten jam nut once straight. You may need to do this more than once after a drive to get it straight to your liking. Test brakes and verify no leakage in lines before driving. Recheck often. Removal or trimming of factory plastic inner fender liner may be required to clear combinations of larger tire sizes and wheel back spacings. Check for acceptable clearance. Retorque all bolts after 500 miles.

**After alignment is complete and no additional adjustments are to be made to control arms. Torque all 1" Jam Nuts to 250 ft/lbs and all 1-1/4" Jam Nuts torque to 300 ft/lbs. Regularly check all jam nuts and punch bolts on all control arms for proper torque/tightness. Failure to do so may cause premature wear of threads on arms.**

Size	Recommended Torque											
	Grade 2		Grade 5		Grade 8		18-8 S/S		Bronze		Brass	
	Coarse	Fine	Coarse	Fine	Coarse	Fine	Coarse	Fine	Coarse	Fine	Coarse	Fine
<b>#4*</b>	-	-	-	-	-	-	5.2	-	4.8	-	4.3	-
<b>#6*</b>	-	-	-	-	-	-	9.6	-	8.9	-	7.9	-
<b>#8*</b>	-	-	-	-	-	-	19.8	-	18.4	-	16.2	-
<b>#10*</b>	-	-	-	-	-	-	22.8	31.7	21.2	29.3	18.6	25.9
<b>1/4</b>	4	4.7	6.3	7.3	9	10	6.3	7.8	5.7	7.3	5.1	6.4
<b>5/16</b>	8	9	13	14	18	20	11	11.8	10.3	10.9	8.9	9.7
<b>3/8</b>	15	17	23	26	33	37	20	22	18	20	16	18
<b>7/16</b>	24	27	37	41	52	58	31	33	29	31	26	27
<b>1/2</b>	37	41	57	64	80	90	43	45	40	42	35	37
<b>9/16</b>	53	59	82	91	115	129	57	63	53	58	47	51
<b>5/8</b>	73	83	112	128	159	180	93	104	86	96	76	85
<b>3/4</b>	125	138	200	223	282	315	128	124	104	102	118	115
<b>7/8</b>	129	144	322	355	454	501	194	193	178	178	159	158
<b>1†</b>	188	210	483	541	682	764	287	289	265	240	235	212



EVO Manufacturing

2.5" Jeep Wrangler JL 2018+

Boost and Overland Boost Instruction Manual



Wheel spacers or aftermarket wheels with a smaller backspacing than factory (4.75" or smaller number is recommended) are required for a complete installation. If installing EVO MFG Enforcer Control Arms: All Vehicles that spend time on salted roads. It is recommended that removal of control arm joint (threaded one) on all control arms before installation of vehicle. Apply a small amount of Anti Seize on threads and reassemble. ALWAYS wear safety glasses and other approved safety gear when working on a vehicle. All factory bolts should be tightened to factory specifications. All supplied bolts torqued according to chart at end of instruction.

1. Safely and securely park vehicle on level ground with parking brake applied.
2. Use wheel chokes to block rear tires from rolling
3. Loosen all front and rear control arm and trackbar bolts at both axle and frame. DO NOT REMOVE (unless installing EVO Enforcer Arms). Just loosen a few turns to remove bolt compression on control arm bushings. If installing EVO Enforcer arms. Do so at this time. Remove and replace one arm at a time. **Keep bolts loose (installed but un-torqued) as described above. We will torque later at end of complete installation.**

FRONT LOWER JL ENFORCER ARM STARTING LEGNTH CENTER TO CENTER 24 1/8"

FRONT UPPER JL ENFORCER ARM STARTING LEGNTH CENTER TO CENTER 20 1/4"

REAR LOWER JL ENFORCER ARM STARTING LEGNTH CENTER TO CENTER 19 3/4"

REAR UPPER JL ENFORCER ARM STARTING LEGNTH CENTER TO CENTER 17 1/2"

## FRONT INSTALL

4. Carefully lift front of vehicle by front frame rails extending suspension until tires leave the ground.
5. Securely place weight approved jack stands for vehicle under frame.
6. With vehicle front tires now suspended and frame securely supported on stands, remove front tires from vehicle.
7. Remove bolt from driver and pass side brake line bracket at frame just behind front coils.
8. Remove both driver and passenger side swaybar links bolts at axle and swaybar removing swaybar links and rotate sway up and out of the way. Factory front links will not be reused.
9. Disconnect push-in clip from front upper control arm mounts at axle holding wire.
10. **Vehicle wiring and hoses vary, make sure all wires, hoses, lines etc from frame to axle are freed up giving ample length to move axle downward as needed before proceeding, verify wiring/hoses etc do not get stretched while lowering axle in next steps.**
11. Lightly jack front driver side axle tube slightly. With axle slightly supported remove front lower shock bolt from axle. Varying axle jack tension to the right amount will alleviate load on the bolt and allow it to freely slide out. If you are replacing shocks and not using shock extensions



remove upper bolt and remove shock. Otherwise leave shock mounted at upper. Support driver side axle with jack stand and repeat this step on passenger side.

12. Remove trackbar bolt at axle. This will allow the axle to move side to side so be cautious about this from here on.
13. Lower jack under axle giving room and remove front spring. Keep track of which spring is driver and passenger.
14. Insert driveside EVO coil spacer up into coil pocket around bump tube. Install supplied  $\frac{1}{4}$ " .75 bolt through rear back hole in frame coil seat and EVO coil mount. Tighten bolt to below chart at end of instruction.



15. Insert supplied  $\frac{3}{8}$  x 2" bolt into front bumpstop extension. Place bumpstop with bolt inside (bore side up) factory spring and reinstall factory coil spring and rubber isolator on top of coil into its original location on both the frame and axle. Isolator will now be seated on the EVO coil spacer. Axle may need to be lowered to install.

16. With spring in place and bumpstop extension sitting on axle pad and bolt inserted into bumpstop extension. Install supplied  $\frac{3}{8}$ " nut from under spring pad to bolt inserted inside bumpstop extension and tighten.

## OVERLAND KITS:



If you are installing Overland kit with Front Control Arm Relocation brackets. Follow these instruction: If not continue to next numbered step.

With axle and frame/vehicle safely supported. Loosen but do not remove bolt or nut on both upper and lower control bolts at their axle connections. Remove heat shield from upper control arm at frame and unbolt upper driver side upper control arm from frame. Unbolt lower control arm at frame **being very cautious and careful as the axle will no longer be connected to vehicle on the driver side at this time.** Rotate control arms out of the way and insert driver side control arm relocation brackets into frame pockets where control arms were once mounted. In both upper and lower arm location where bracket connects with frame insert supplied crush tube into gaps (shorter sleeve for upper mount and longer tube for lower mount). Use factory bolts to frame locations through EVO brackets and crush sleeves. Torque all frame bolts at EVO control arm brackets to factory specifications.

Rotate control arms back into their new location on the EVO Control arm relocation brackets. Use Supplied M12 bolt, washers and nut for upper control arm mount and 5/8 bolt, washers, nut for lower control arm mount.

17. Install front EVO brake line extension bracket at original brake line mounting location on frame with factory bolt.



18. Install factory brake line to the new lower location on the EVO brake line extension bracket. **Be very careful moving line into new location. The factory hardline will need to be slightly manipulated to be relocated. Do not use tools or pinch/crack the line.**

19. Reinstall shock at axle per factory specifications. If you are installing shock extensions. Do so at this time. Follow instructions for that kit. If you are installing new shocks, install shocks at both upper and lower mounting locations. Torque to factory specifications.

If new Lower EVO MFG Enforcer Arms have been installed. Carefully enlarge/drill brake line bracket mounting hole

that once attached to factory lower arm to ½” and install on shock bolt after shock bolts have been torqued. Use M12 nut supplied with EVO Enforcer Control Arms. Series: Shock nut, brake line bracket, Flange Nut.

20. Repeat steps 10-19 on passenger side including Overland kit section is applicable.
21. Reinstall wheel and torque to factory specifications.
22. Carefully lift vehicle by frame, remove jack stands and lower to ground. When lowering be mindful of the front trackbar at axle this is not bolted in. It will need to be guided into its bracket at the axle while lowering the vehicle. When on the ground carefully turn steering without ending running and in park with parking brake on and wheels chalked until trackbar lines up with hole in trackbar bracket. Insert factory bolt and loosely tighten bolt.
- 23. Torque all control arm bolts, uppers, lowers at frame and axle. Torque all shock bolts at frame and axle. Torque front trackbar bolt. Check and torque all other bolts. Use chart below for supplied hardware. Use factory specifications for factory hardware.**
24. Front swaybar links should be left uninstalled at this time. We will install factory rear swaybar links on the front later in the process.

## REAR Install

25. Safely and securely park vehicle on level ground with parking brake applied.
26. Use wheel chocks to block front tires from rolling
27. While safely parked on ground. Loosen all rear control arm and trackbar bolts at both axle and frame. DO NOT REMOVE (unless installing EVO Enforcer Arms). Just loosen a few turns to remove bolt compression on control arm bushings. If installing EVO Enforcer arms. Do so at this time. Remove and replace one arm at a time. Keep bolts loose (installed but un-torqued) as described above.
28. Carefully lift rear of vehicle by frame rails/crossmember extending suspension until tires leave the ground.
29. Securely place weight approved jack stands for vehicle under frame.
30. With vehicle rear tires now suspended and frame securely supported on stands, remove rear tires from vehicle.
31. Remove both driver and passenger side swaybar links bolts at axle and swaybar removing swaybar links and rotate away up and out of the way.
- 32. Vehicle wiring and hoses vary, make sure all wires, hoses, lines etc from chassis to axle are freed up giving ample length to move axle downward as needed before proceeding, verify wiring/hoses etc do not get stretched while lowering axle in next steps.**



side

33. Lightly jack front driver side axle tube slightly. With axle slightly supported remove front lower shock bolt from axle. Varying axle jack tension to the right amount will alleviate load on the bolt and allow it to freely slide out. If you are replacing shocks and not using shock extensions remove upper bolt and remove shock. Otherwise leave shock mounted at upper. Support driver side axle with jack stand and repeat this step on passenger side.

34. Lower jack under axle giving room and remove rear springs. Keep note of which spring is driver and passenger.

35. Install rear bump stop extensions to axle pads on both passenger and driver side axle pads using supplied  $5/16'' \times .75$  bolts, washers and nuts.

36. Install EVO driver side coil spring spacer into upper coil pocket on frame using supplied  $7/16'' \times 1$  bolts, washers and nuts. Insert bolts from top down through frame then EVO bracket.

37. Repeat on passenger



38. Reinstall driver and passenger side coil springs into place keeping factory rubber isolator on top of spring. Be sure to align nub on isolator so that it inserts into hole in EVO brackets. The spring isolator will now be resting on the EVO coil spring spacer.
39. Assemble supplied rear swaybar links. Using light oil such as WD 40. Lubricate inner surface of link loops. Tap or vice in supplied rubber bushings. Lubricate inner surface of rubber bushings. Tap or vice in supplied swaybar tube sleeves.
40. With rear spring installed. Jack axle up until shock bolts line up with axle mounting holes. **Be very aware that vehicle does not lift off chassis/frame jack stands.** If you are installing new shocks or shock extensions, do so at this time. Follow factory torque specs for shock bolts.
41. Using 2 factory swaybar bolts and 2 supplied M12 x 60 bolts washers and nuts install assembled EVO swaybar links to axle on outside of swaybar tab and outside of swaybar itself (outside outside).
42. Reconnect all disconnected hoses, wires etc.
43. Reinstall rear wheels and torque to factory specs
44. Carefully jack vehicle by frame and remove jack stands.
45. Lower vehicle to ground.
46. Install factory rear swaybar link onto the front axle and front sway. Rubber bushing side on factory link goes inside the two tabs on the axle and stud mount to outside of swaybar. Bend in link should jog upwards moving studded end toward tire.
47. **Torque all control arm bolts, uppers, lowers at frame and axle. Torque all shock bolts at frame and axle. Torque front trackbar bolt. Check and torque all other bolts. Use chart below for supplied hardware. Use factory specifications for factory hardware.**

RECENTER STEERING WHEEL by Adjusting Turn buckle on Draglink. Make sure to turn the correct way to center (do not do a full rotation of steering wheel, closest direction to straight, watch wheel

while turning) and tighten jam nut once straight. You may need to do this more than once after a drive to get it straight to your liking. Test brakes and verify no leakage in lines before driving. Recheck often. Removal or trimming of factory plastic inner fender liner may be required to clear combinations of larger tire sizes and wheel back spacings. Check for acceptable clearance. Retorque all bolts after 500 miles.

Size	Recommended Torque											
	Grade 2		Grade 5		Grade 8		18-8 S/S		Bronze		Brass	
	Coarse	Fine	Coarse	Fine	Coarse	Fine	Coarse	Fine	Coarse	Fine	Coarse	Fine
<b>#4*</b>	-	-	-	-	-	-	5.2	-	4.8	-	4.3	-
<b>#6*</b>	-	-	-	-	-	-	9.6	-	8.9	-	7.9	-
<b>#8*</b>	-	-	-	-	-	-	19.8	-	18.4	-	16.2	-
<b>#10*</b>	-	-	-	-	-	-	22.8	31.7	21.2	29.3	18.6	25.9
<b>1/4</b>	4	4.7	6.3	7.3	9	10	6.3	7.8	5.7	7.3	5.1	6.4
<b>5/16</b>	8	9	13	14	18	20	11	11.8	10.3	10.9	8.9	9.7
<b>3/8</b>	15	17	23	26	33	37	20	22	18	20	16	18
<b>7/16</b>	24	27	37	41	52	58	31	33	29	31	26	27
<b>1/2</b>	37	41	57	64	80	90	43	45	40	42	35	37
<b>9/16</b>	53	59	82	91	115	129	57	63	53	58	47	51
<b>5/8</b>	73	83	112	128	159	180	93	104	86	96	76	85
<b>3/4</b>	125	138	200	223	282	315	128	124	104	102	118	115
<b>7/8</b>	129	144	322	355	454	501	194	193	178	178	159	158
<b>1†</b>	188	210	483	541	682	764	287	289	265	240	235	212



EVO Manufacturing  
Jeep Wrangler JL and JT Gladiator  
JL/JT Overland Drop Bracket  
EVO- 3003B







Before starting installation procedure please read <http://evomfg.com>Returns-Warranties-Shipping>

**CAREFULLY READ AND FOLLOW ALL INSTRUCTIONS IN THIS MANUAL AND KEEP FOR FUTURE REFERENCE. IF YOU HAVE ANY QUESTIONS ABOUT THE PRODUCT CALL EVO MANUFACTURING. FAILURE TO FOLLOW GUIDELINES COULD RESULT IN MALFUNCTION OF PARTS OR INJURY. PLEASE HAVE A TRAINED PROFESSIONAL ASSIST WITH OR INSTALL ALL PRODUCTS. INSTALLING EVO MFG PRODUCTS OR KITS DEMANDS SPECIFIC KNOWLEDGE, TOOLS AND EXPERIENCE. GENERAL KNOWLEDGE OF HOW TO USE LATER SPECIFIED TOOLS AND/OR LIMITED EXPERIENCE WITH EVO MFG PRODUCTS MAY NOT BE ENOUGH TO PROPERLY COMPLETE THESE TASKS. SOME OF EVO MFG PRODUCTS MAY REQUIRE TWO OR MORE PEOPLE TO INSTALL SAFELY AND CORRECTLY. DO NOT ATTEMPT ALONE, ALWAYS ENLIST THE HELP OF TRAINED PROFESSIONAL WHEN NEEDED.**

**Notes: Set Up Before installation**

**This instruction is specifically for installing the EVO MFG Overland Drop Brackets**

**This is a component instruction for overland brackets. Depending on setup/stage of vehicle, instructions may need to be conformed around individual's situation/parts/setup.**

**Keep all mounting bolts loose (installed but not torqued) we will torque later at the end of complete installation**

**READ BEFORE INSTALL:**

It is generally a good idea to apply Loctite to all threaded bolts.

ALWAYS wear safety glasses and other approved safety gear when working on a vehicle.

All supplied bolts torqued according to chart at end of instruction.

It is recommended all installation be performed by a trained professional. Some modification may have to be done.



Parts included: Table below shows black (painted) EVO MFG Overland brackets.

Description	#	Part #	Quantity
Driver CA Drop JL	1	EVO-12300B	1
Passenger CA Drop JL	2	EVO-12301B	2
Crush Tube, Drop Lower	3	EVO-20037	1
Crush Tube, Drop Upper	4	EVO-20036	1
Relocation Hardware Kit	5	EVO-770073	1





#### **Recommended Tools:**

- Impact with sockets set
  - Wrench/Socket Wrench Set
- 



#### **Safety Steps for installation**

- For installing EVO MFG products always use wheel chokes to block rear tires from rolling.
  - Always make sure you have everything necessary ready before install.
  - If you have to, carefully lift front of vehicle by front frame rails extending suspension until tires leave the ground, place frame on approved jack stands for vehicle. Verify all lines/wires are not over extended.
  - Remove tires if needed for easier install.
  - Make sure to wear safety equipment (eye protection, hand protection, foot protection etc.) at all times during installation.
  - Make sure all safety precautions have been taken.
  - Always check and replace any part of vehicle that is worn or broken before starting install.
  - Do not mix anything EVO with weaker alternatives.
  - It is generally a good idea to apply liquid threadlock to all bolts.
  - Tighten included hardware to torque specifications in bottom table unless it is otherwise specified, factory bolts should be torqued to factory Jeep specifications.
- 





## INSTALL

**Safely park vehicle on flat ground, put in park and chalk tires.**

1. Starting on driver side front, loosen but do not remove bolt or nut on both upper and lower control arm bolts at their axle connections.
2. Remove heat shield from upper control arm at frame and unbolt driver side upper control arm from frame.
3. Unbolt lower control arm at frame





**Being very cautious and careful as the axle will no longer be connected to vehicle on the driver side at this time.**

4. Rotate control arms out of the way and insert driver side control arm relocation brackets into frame pockets where control arms were once mounted.
5. In both upper and lower arm location where bracket connects with frame insert supplied crush tube into gaps (shorter sleeve for upper mount and longer tube for lower mount). Use factory bolts to frame locations through EVO brackets and crush sleeves.
6. Torque all frame bolts at EVO control arm brackets to factory specifications.

Rotate control arms back into their new location on the EVO Control arm relocation brackets. Use Supplied M12 bolt, washers and nut for upper control arm mount and 5/8 bolt, washers, nut for lower control arm mount.

---



**Repeat all steps above for passenger side.**



After Install:

- Tighten all bolts securing purchased parts to specified locations.
- After completing installation using provided instructions, go through all steps again to make sure nothing was missed, not tightened or improperly assembled.
- Some components may need to be purchased separately.
- Check turn signals, headlights, fog lights (if applicable), taillights, blinkers and windshield wipers.
- Adjust mirrors, speedometer and headlights if needed.
- Make sure all gauges are fully operational.
- Drive the vehicle slowly for a couple minutes, looking and listening for abnormal noises while driving. After modification of a vehicle there will be differences in driving experiences and capabilities, be mindful of that.
- Inspect and Retorque all Bolts after 500 miles of completed installation and regularly thereafter.
- Some modification may be required.

Recommended Torque:

Size	Grade 2		Grade 5		Grade 8		18-8 S/S	
	Coarse	Fine	Coarse	Fine	Coarse	Fine	Coarse	Fine
<b>#4*</b>	-	-	-	-	-	-	5.2	-
<b>#6*</b>	-	-	-	-	-	-	9.6	-
<b>#8*</b>	-	-	-	-	-	-	19.8	-
<b>#10*</b>	-	-	-	-	-	-	22.8	31.7
<b>1/4</b>	4	4.7	6.3	7.3	9	10	6.3	7.8
<b>5/16</b>	8	9	13	14	18	20	11	11.8
<b>3/8</b>	15	17	23	26	33	37	20	22
<b>7/16</b>	24	27	37	41	52	58	31	33
<b>1/2</b>	37	41	57	64	80	90	43	45
<b>9/16</b>	53	59	82	91	115	129	57	63
<b>5/8</b>	73	83	112	128	159	180	93	104
<b>3/4</b>	125	138	200	223	282	315	128	124
<b>7/8</b>	129	144	322	355	454	501	194	193
<b>1†</b>	188	210	483	541	682	764	287	289



EVO Manufacturing  
Jeep Wrangler JL and JT Gladiator  
JL/JT Overland Drop Bracket  
EVO- 3003B





Before starting installation procedure please read <http://evomfg.com>Returns-Warranties-Shipping>

**CAREFULLY READ AND FOLLOW ALL INSTRUCTIONS IN THIS MANUAL AND KEEP FOR FUTURE REFERENCE. IF YOU HAVE ANY QUESTIONS ABOUT THE PRODUCT CALL EVO MANUFACTURING. FAILURE TO FOLLOW GUIDELINES COULD RESULT IN MALFUNCTION OF PARTS OR INJURY. PLEASE HAVE A TRAINED PROFESSIONAL ASSIST WITH OR INSTALL ALL PRODUCTS. INSTALLING EVO MFG PRODUCTS OR KITS DEMANDS SPECIFIC KNOWLEDGE, TOOLS AND EXPERIENCE. GENERAL KNOWLEDGE OF HOW TO USE LATER SPECIFIED TOOLS AND/OR LIMITED EXPERIENCE WITH EVO MFG PRODUCTS MAY NOT BE ENOUGH TO PROPERLY COMPLETE THESE TASKS. SOME OF EVO MFG PRODUCTS MAY REQUIRE TWO OR MORE PEOPLE TO INSTALL SAFELY AND CORRECTLY. DO NOT ATTEMPT ALONE, ALWAYS ENLIST THE HELP OF TRAINED PROFESSIONAL WHEN NEEDED.**

**Notes: Set Up Before installation**

**This instruction is specifically for installing the EVO MFG Overland Drop Brackets**

**This is a component instruction for overland brackets. Depending on setup/stage of vehicle, instructions may need to be conformed around individual's situation/parts/setup.**

**Keep all mounting bolts loose (installed but not torqued) we will torque later at the end of complete installation**

**READ BEFORE INSTALL:**

It is generally a good idea to apply Loctite to all threaded bolts.

ALWAYS wear safety glasses and other approved safety gear when working on a vehicle.

All supplied bolts torqued according to chart at end of instruction.

It is recommended all installation be performed by a trained professional. Some modification may have to be done.





Parts included: Table below shows black (painted) EVO MFG Overland brackets.

Description	#	Part #	Quantity
Driver CA Drop JL	1	EVO-12300B	1
Passenger CA Drop JL	2	EVO-12301B	2
Crush Tube, Drop Lower	3	EVO-20037	1
Crush Tube, Drop Upper	4	EVO-20036	1
Relocation Hardware Kit	5	EVO-770073	1





#### **Recommended Tools:**

- Impact with sockets set
  - Wrench/Socket Wrench Set
- 



#### **Safety Steps for installation**

- For installing EVO MFG products always use wheel chokes to block rear tires from rolling.
  - Always make sure you have everything necessary ready before install.
  - If you have to, carefully lift front of vehicle by front frame rails extending suspension until tires leave the ground, place frame on approved jack stands for vehicle. Verify all lines/wires are not over extended.
  - Remove tires if needed for easier install.
  - Make sure to wear safety equipment (eye protection, hand protection, foot protection etc.) at all times during installation.
  - Make sure all safety precautions have been taken.
  - Always check and replace any part of vehicle that is worn or broken before starting install.
  - Do not mix anything EVO with weaker alternatives.
  - It is generally a good idea to apply liquid threadlock to all bolts.
  - Tighten included hardware to torque specifications in bottom table unless it is otherwise specified, factory bolts should be torqued to factory Jeep specifications.
- 





## **INSTALL**

**Safely park vehicle on flat ground, put in park and chalk tires.**

1. Starting on driver side front, loosen but do not remove bolt or nut on both upper and lower control arm bolts at their axle connections.
2. Remove heat shield from upper control arm at frame and unbolt driver side upper control arm from frame.
3. Unbolt lower control arm at frame





**Being very cautious and careful as the axle will no longer be connected to vehicle on the driver side at this time.**

4. Rotate control arms out of the way and insert driver side control arm relocation brackets into frame pockets where control arms were once mounted.
5. In both upper and lower arm location where bracket connects with frame insert supplied crush tube into gaps (shorter sleeve for upper mount and longer tube for lower mount). Use factory bolts to frame locations through EVO brackets and crush sleeves.
6. Torque all frame bolts at EVO control arm brackets to factory specifications.

Rotate control arms back into their new location on the EVO Control arm relocation brackets. Use Supplied M12 bolt, washers and nut for upper control arm mount and 5/8 bolt, washers, nut for lower control arm mount.

---



**Repeat all steps above for passenger side.**



After Install:

- Tighten all bolts securing purchased parts to specified locations.
- After completing installation using provided instructions, go through all steps again to make sure nothing was missed, not tightened or improperly assembled.
- Some components may need to be purchased separately.
- Check turn signals, headlights, fog lights (if applicable), taillights, blinkers and windshield wipers.
- Adjust mirrors, speedometer and headlights if needed.
- Make sure all gauges are fully operational.
- Drive the vehicle slowly for a couple minutes, looking and listening for abnormal noises while driving. After modification of a vehicle there will be differences in driving experiences and capabilities, be mindful of that.
- Inspect and Retorque all Bolts after 500 miles of completed installation and regularly thereafter.
- Some modification may be required.

Recommended Torque:

Size	Grade 2		Grade 5		Grade 8		18-8 S/S	
	Coarse	Fine	Coarse	Fine	Coarse	Fine	Coarse	Fine
<b>#4*</b>	-	-	-	-	-	-	5.2	-
<b>#6*</b>	-	-	-	-	-	-	9.6	-
<b>#8*</b>	-	-	-	-	-	-	19.8	-
<b>#10*</b>	-	-	-	-	-	-	22.8	31.7
<b>1/4</b>	4	4.7	6.3	7.3	9	10	6.3	7.8
<b>5/16</b>	8	9	13	14	18	20	11	11.8
<b>3/8</b>	15	17	23	26	33	37	20	22
<b>7/16</b>	24	27	37	41	52	58	31	33
<b>1/2</b>	37	41	57	64	80	90	43	45
<b>9/16</b>	53	59	82	91	115	129	57	63
<b>5/8</b>	73	83	112	128	159	180	93	104
<b>3/4</b>	125	138	200	223	282	315	128	124
<b>7/8</b>	129	144	322	355	454	501	194	193
<b>1†</b>	188	210	483	541	682	764	287	289



EVO Manufacturing

Jeep Wrangler JL 2018+

SHOCK EXTENSION Instruction Manual





#### Front Install

1. Safely park vehicle on level ground. Chalk front and back tires. Put vehicle in park with parking brake on.
2. Remove front shock bolt at axle
3. Install EVO Shock Extension Bracket as shown
4. Install supplied 3/8 bolt washer and nut in hole at lower face of bracket
5. Use supplied crush tube inside shock mount at Lower/Original shock mount location. Install supplied M12 bolt, washers and nut through all brackets and crush sleeve. (Lower/Original Shock Location)
6. Install shock at new higher location in EVO Bracket with factory shock bolt.
7. Tighten all bolts



#### Rear Install

1. Safely park vehicle on level ground. Chalk front and back tires. Put vehicle in park with parking brake on.
2. Remove Rear shock bolt at axle
3. Remove Swaybar link at axle
4. Install EVO Shock Extension bracket as shock. There are a left and right mirror brackets.
5. Install 3/8" bolt washer and nut in middle hole of EVO Bracket into the factory hole on the rear control arm mount.
6. Install Swaybar link on outside of factory tab using factory bolt through factory tab and EVO bracket. Bottom hole.
7. Mark and drill 3/8 hole on bottom of EVO Bracket between new shock location.
8. Install supplied 3/8 bolt washers and nut in drilled hole.
9. Install shock in new higher location with factory hardware.
10. Torque all bolts.



Retorque all bolts after 500 miles.

Size	Recommended Torque											
	Grade 2		Grade 5		Grade 8		18-8 S/S		Bronze		Brass	
	Coarse	Fine	Coarse	Fine	Coarse	Fine	Coarse	Fine	Coarse	Fine	Coarse	Fine
<b>#4*</b>	-	-	-	-	-	-	5.2	-	4.8	-	4.3	-
<b>#6*</b>	-	-	-	-	-	-	9.6	-	8.9	-	7.9	-
<b>#8*</b>	-	-	-	-	-	-	19.8	-	18.4	-	16.2	-
<b>#10*</b>	-	-	-	-	-	-	22.8	31.7	21.2	29.3	18.6	25.9
<b>1/4</b>	4	4.7	6.3	7.3	9	10	6.3	7.8	5.7	7.3	5.1	6.4
<b>5/16</b>	8	9	13	14	18	20	11	11.8	10.3	10.9	8.9	9.7
<b>3/8</b>	15	17	23	26	33	37	20	22	18	20	16	18
<b>7/16</b>	24	27	37	41	52	58	31	33	29	31	26	27
<b>1/2</b>	37	41	57	64	80	90	43	45	40	42	35	37
<b>9/16</b>	53	59	82	91	115	129	57	63	53	58	47	51
<b>5/8</b>	73	83	112	128	159	180	93	104	86	96	76	85
<b>3/4</b>	125	138	200	223	282	315	128	124	104	102	118	115
<b>7/8</b>	129	144	322	355	454	501	194	193	178	178	159	158
<b>1+</b>	188	210	483	541	682	764	287	289	265	240	235	212



EVO Manufacturing

Jeep Wrangler JL/JT Gladiator

JL/JT Control Arms

EVO- 3082B, 3081B, 3007B, 3006B, 1175B, 1174B





Before starting installation procedure please read <http://evomfg.com>Returns-Warranties-Shipping>

**CAREFULLY READ AND FOLLOW ALL INSTRUCTIONS IN THIS MANUAL AND KEEP FOR FUTURE REFERENCE. IF YOU HAVE ANY QUESTIONS ABOUT THE PRODUCT CALL EVO MANUFACTURING. FAILURE TO FOLLOW GUIDELINES COULD RESULT IN MALFUNCTION OF PARTS OR INJURY. PLEASE HAVE A TRAINED PROFESSIONAL ASSIST WITH OR INSTALL ALL PRODUCTS. INSTALLING EVO MFG PRODUCTS OR KITS DEMANDS SPECIFIC KNOWLEDGE, TOOLS AND EXPERIENCE. GENERAL KNOWLEDGE OF HOW TO USE LATER SPECIFIED TOOLS AND/OR LIMITED EXPERIENCE WITH EVO MFG PRODUCTS MAY NOT BE ENOUGH TO PROPERLY COMPLETE THESE TASKS. SOME OF EVO MFG PRODUCTS MAY REQUIRE TWO OR MORE PEOPLE TO INSTALL SAFELY AND CORRECTLY. DO NOT ATTEMPT ALONE, ALWAYS ENLIST THE HELP OF TRAINED PROFESSIONAL WHEN NEEDED.**

**Notes: Set Up Before installation**

**This is a general instruction for this component kit.**

**Directions/pictures may vary for each specific install, use for reference only.**

**Keep all mounting bolts loose (installed but not torqued) we will torque later at the end of complete installation**

**Do not remove more than two control arms at a time**

**FRONT LOWER JL ENFORCER ARM STARTING LEGNTH CENTER TO CENTER, 24 1/8"**

**FRONT UPPER JL ENFORCER ARM STARTING LEGNTH CENTER TO CENTER, 20 1/4"**

**REAR LOWER JL ENFORCER ARM STARTING LEGNTH CENTER TO CENTER, 19 3/4"**

**REAR UPPER JL ENFORCER ARM STARTING LEGNTH CENTER TO CENTER, 17 1/2"**

**READ BEFORE INSTALL:**

ALL measurements stated above are starting points only, every vehicle is different. Professional alignment is recommended.

It is generally a good idea to apply Loctite to all threaded bolts.

ALWAYS wear safety glasses and other approved safety gear when working on a vehicle.

All supplied bolts torqued according to chart at end of instruction.

It is recommended all installation be performed by a trained professional. Some modification may have to be done.

Paint all unfinished surfaces after install is complete.



Parts included: Table below shows JL/JT Control Arms.

Description	#	Part #	Quantity
Jl Rear Lower Adj Control Arms	1	1174B	2
JL Rear Upper Adj Control Arms	2	1175B	2
JL/JT Front Lower Control Arms	3	3006B	2
JL/JT Front Upper Control Arms	4	3007B	2
JT Rear Adj Upper Control Arms	5	3081B	2
JT Rear Adj Lower Control Arms	6	3082B	2

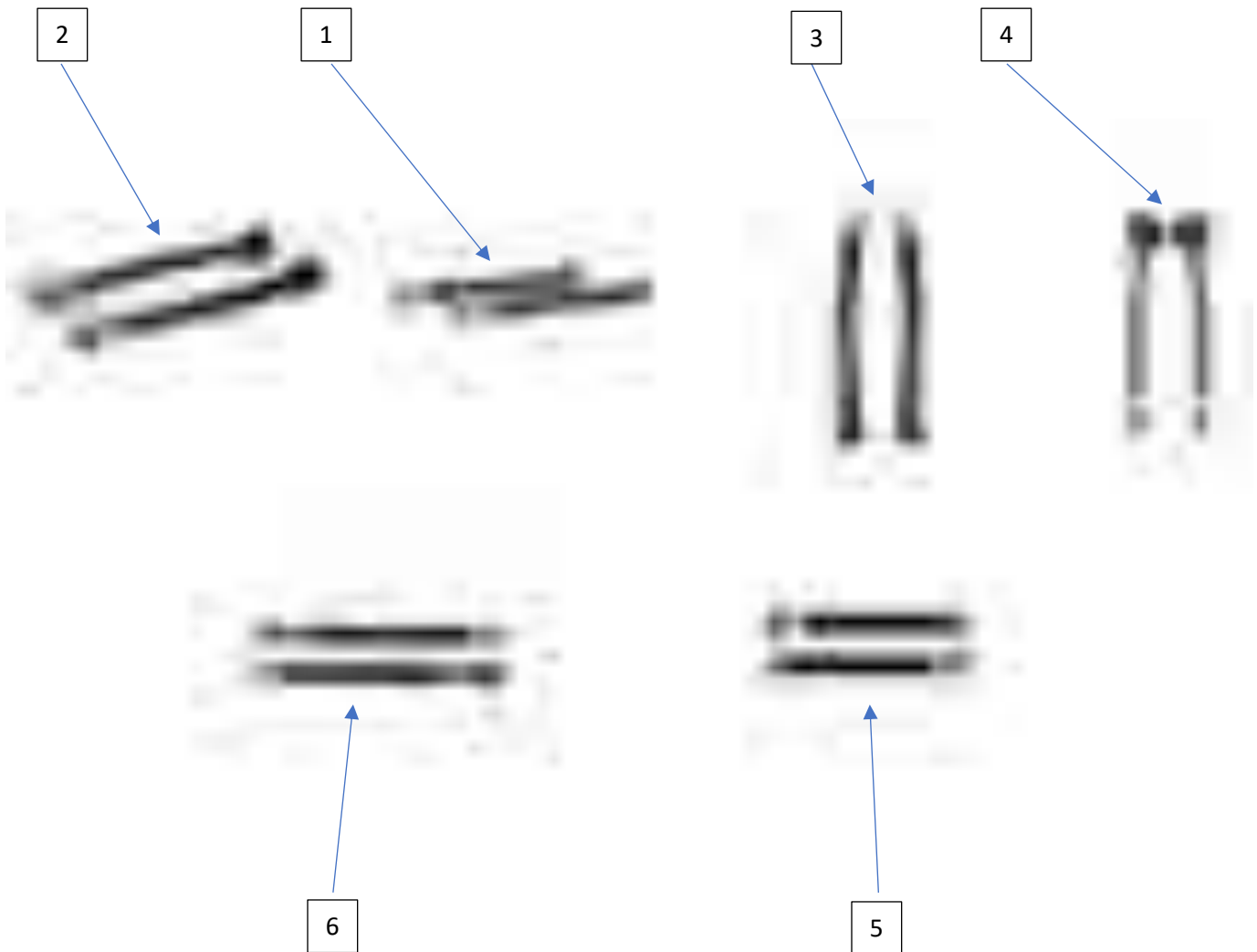



#### **Recommended Tools:**

- Standard socket set w/ wrench
  - OR Standard wrench set
- 



#### Safety Steps for installation

- For installing EVO MFG products always use wheel chokes to block rear tires from rolling.
  - Always make sure you have everything necessary ready before install.
  - If you have to, carefully lift front of vehicle by front frame rails extending suspension until tires leave the ground, place frame on approved jack stands for vehicle. Verify all lines/wires are not over extended.
  - Remove tires if needed for easier install.
  - Make sure to wear safety equipment (eye protection, hand protection, foot protection etc.) at all times during installation.
  - Make sure all safety precautions have been taken.
  - Always check and replace any part of vehicle that is worn or broken before starting install.
  - Do not mix anything EVO with weaker alternatives.
  - It is generally a good idea to apply liquid threadlock to all bolts.
  - Tighten included hardware to torque specifications in bottom table unless it is otherwise specified, factory bolts should be torqued to factory Jeep specifications.
- 





**After alignment is complete and no additional adjustments are to be made to control arms. Torque all 1" Jam Nuts to 250 ft/lbs and all 1-1/4" Jam Nuts torque to 300 ft/lbs. Regularly check all jam nuts and punch bolts on all control arms for proper torque/tightness. Failure to do so may cause premature wear of threads on arms.**

For front upper control arms:

1. Disconnect push-in clip from front upper control arm mounts at axle holding wire.

For all other arms:

2. Remove and replace one arm at a time. Keep bolts loose (installed but un-torqued) as described above. We will torque later in the installation process.

Use pictures as reference.



3. Make sure zerk fittings are facing up and at adjustable end at axle.
4. Adjustable end of control arms should be on the axle side.
5. Reuse factory hardware to mount EVO MFG control arms.

Note: For front upper control arms, bend in arm should face down.

Use pictures as reference.





Set pinion angle on vehicle so that the driveshaft and the pinion are inline with the axle at an approximate right height and centered to vehicle.

---



---

After Install:

- Tighten all bolts securing purchased parts to specified locations.
- After completing installation using provided instructions, go through all steps again to make sure nothing was missed, not tightened or improperly assembled.
- Some components may need to be purchased separately.
- Check turn signals, headlights, fog lights (if applicable), taillights, blinkers and windshield wipers.
- Adjust mirrors, speedometer and headlights if needed.
- Make sure all gauges are fully operational.
- Drive the vehicle slowly for a couple minutes, looking and listening for abnormal noises while driving. After modification of a vehicle there will be differences in driving experiences and capabilities, be mindful of that.
- Inspect and Retorque all Bolts after 500 miles of completed installation and regularly thereafter.
- Some modification may be required.



Recommended Torque:

Size	Grade 2		Grade 5		Grade 8		18-8 S/S	
	Coarse	Fine	Coarse	Fine	Coarse	Fine	Coarse	Fine
<b>#4*</b>	-	-	-	-	-	-	5.2	-
<b>#6*</b>	-	-	-	-	-	-	9.6	-
<b>#8*</b>	-	-	-	-	-	-	19.8	-
<b>#10*</b>	-	-	-	-	-	-	22.8	31.7
<b>1/4</b>	4	4.7	6.3	7.3	9	10	6.3	7.8
<b>5/16</b>	8	9	13	14	18	20	11	11.8
<b>3/8</b>	15	17	23	26	33	37	20	22
<b>7/16</b>	24	27	37	41	52	58	31	33
<b>1/2</b>	37	41	57	64	80	90	43	45
<b>9/16</b>	53	59	82	91	115	129	57	63
<b>5/8</b>	73	83	112	128	159	180	93	104
<b>3/4</b>	125	138	200	223	282	315	128	124
<b>7/8</b>	129	144	322	355	454	501	194	193
<b>1†</b>	188	210	483	541	682	764	287	289





EVO Manufacturing  
Jeep Wrangler JL Unlimited 2018+  
High Clearance Long Arm Kit Instruction Manual  
EVO-3010

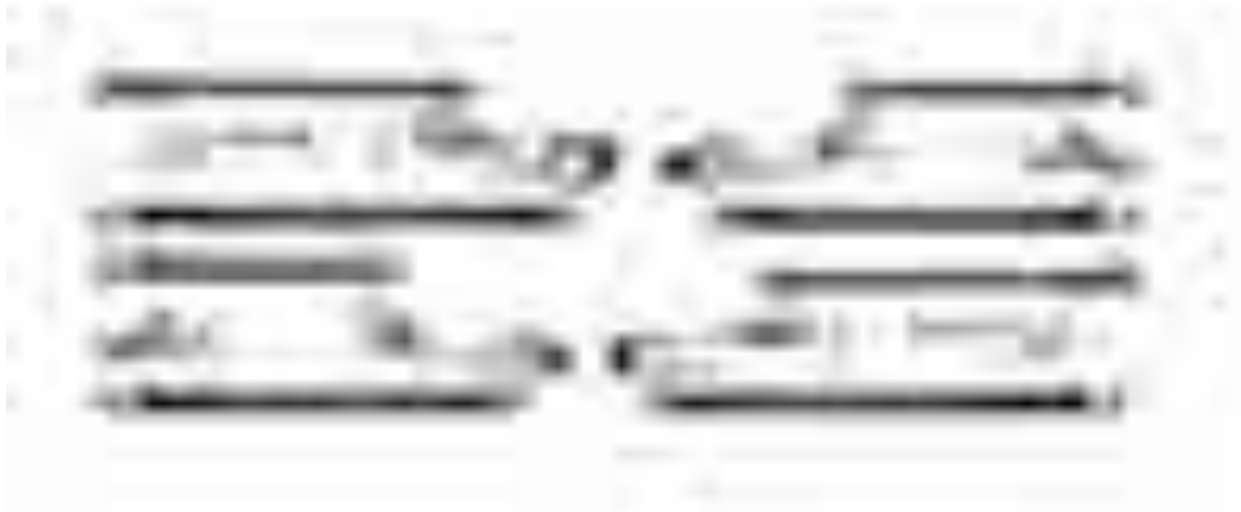

**FOR 4 DOOR JLU MODELS ONLY**



Before starting installation procedure please read <http://evomfg.com>Returns-Warranties-Shipping>

**CAREFULLY READ AND FOLLOW ALL INSTRUCTIONS IN THIS MANUAL AND KEEP FOR FUTURE REFERENCE. IF YOU HAVE ANY QUESTIONS ABOUT THE PRODUCT CALL EVO MANUFACTURING. FAILURE TO FOLLOW GUIDELINES COULD RESULT IN MALFUNCTION OF PARTS OR INJURY. PLEASE HAVE A TRAINED PROFESSIONAL ASSIST WITH OR INSTALL ALL PRODUCTS. INSTALLING EVO MFG PRODUCTS OR KITS DEMANDS SPECIFIC KNOWLEDGE, TOOLS AND EXPERIENCE. GENERAL KNOWLEDGE OF HOW TO USE LATER SPECIFIED TOOLS AND/OR LIMITED EXPERIENCE WITH EVO MFG PRODUCTS MAY NOT BE ENOUGH TO PROPERLY COMPLETE THESE TASKS. SOME OF EVO MFG PRODUCTS MAY REQUIRE TWO OR MORE PEOPLE TO INSTALL SAFELY AND CORRECTLY. DO NOT ATTEMPT ALONE, ALWAYS ENLIST THE HELP OF TRAINED PROFESSIONAL WHEN NEEDED.**

**Notes: Set Up Before installation**

**This kit is compatible with 4 Door JL Unlimited Models Only.**

It requires cutting and grinding of frame mounts and welding of new bracketry.

Gas tank removal is required. This is easiest done when tank is low on fluid.

Wheel spacers or aftermarket wheels with a smaller backspacing than factory are required for a complete installation.

All Vehicles that spend time on salted roads. It is recommended that removal of control arm joint/collar (threaded end) on all control arms before installation of vehicle, apply a small amount of Anti Seize on threads and reassemble.

All factory bolts should be tightened to factory specifications. All supplied bolts torqued according to chart at end of instruction.

This instruction will give procedure of installing the long arm portion of the system first then return to install all other components after the vehicle has been long armed.

**DISCONNECT ALL BATTERY TERMINALS BEFORE STARTING. REINSTALL AT FINAL END OF INSTALLATION**

**Rough Starting lengths for all arms: Professional Alignment after installation recommend.**

<b>ARMS:</b>	<b>FRONT TRACKBAR:</b>	<b>REAR TRACKBAR:</b>
Front Uppers: 26 3/8"	2.5" Lift: 34 1/8"	2.5" Lift: 37 3/4"
Front Lower: 34 1/2"	3.5" Lift: 33 7/8"	3.5" Lift: 37 5/8"
Rear Uppers: 20 1/2"	4.5" Lift: 33 9/16"	4.5" Lift: 37 11/16"
Rear Lower: 30 1/2"		



**READ BEFORE INSTALL:**

It is generally a good idea to apply Loctite to all threaded bolts.

ALWAYS wear safety glasses and other approved safety gear when working on a vehicle.

All supplied bolts torqued according to chart at end of instruction.

It is recommended all installation be performed by a trained professional. Some modification may have to be done.

Test brakes and verify no leakage in lines before driving. Recheck often. Removal or trimming of factory plastic inner fender liner may be required to clear combinations of larger tire sizes and wheel back spacings.

Professional alignment is recommended after install.

**After alignment is complete and no additional adjustments are to be made to control arms. Torque all 1" Jam Nuts to 250 ft/lbs and all 1-1/4" Jam Nuts torque to 300 ft/lbs. Regularly check all jam nuts and punch bolts on all control arms for proper torque/tightness. Failure to do so may cause premature wear of threads on arms and is not covered under warranties.**

**SOME PART ASSEMBLY MAY BE REQUIRED. FOLLOW THESE ASSEMBLY INSTRUCTIONS AT END OF THIS DOCUMENT.**

**Parts included: Table below shows black (painted) EVO MFG JLU Long Arm Pro.**

Description	#	Part #	Quantity
EVO JL Fr Lower Long Arm Pair	1	EVO-12324B	2
EVO JL Rr Lower Long Arm Pair	2	EVO-11061B	2
JL HC Long Arm Hardware	3	EVO-770076	1
9/16-18 Flag Nut Straight Tab 1.5"	4	EVO-12031	4
EVO JL Front Upper LA Driver	5	EVO-11037B	1
EVO JL Front Upper LA Passenger	6	EVO-11038B	1
EVO JL Rear Upper LA Driver	7	EVO-11035B	1
EVO JL Rear Upper LA Passenger	8	EVO-11036B	1
5/8-18 Flag Nut Straight Tab 1.5"	9	EVO-12330	1
Misalignment Spacer 1" Heim 1/16" Bolt 2.625"	10	EVO-100563263	4
EVO JL Fr Driver LA Bracket	11	EVO-12320	1
EVO JL Fr Passenger LA Bracket	12	EVO-12321	1
EVO JL Rr Driver LA Bracket	13	EVO-12322	1
EVO JL Rr Passenger LA Bracket	14	EVO-12323	1
JL Lower Rr Axle LA Mount Dr	15	Unassembled	1
JL Lower Rr Axle LA Mount Pass	16	Unassembled	1

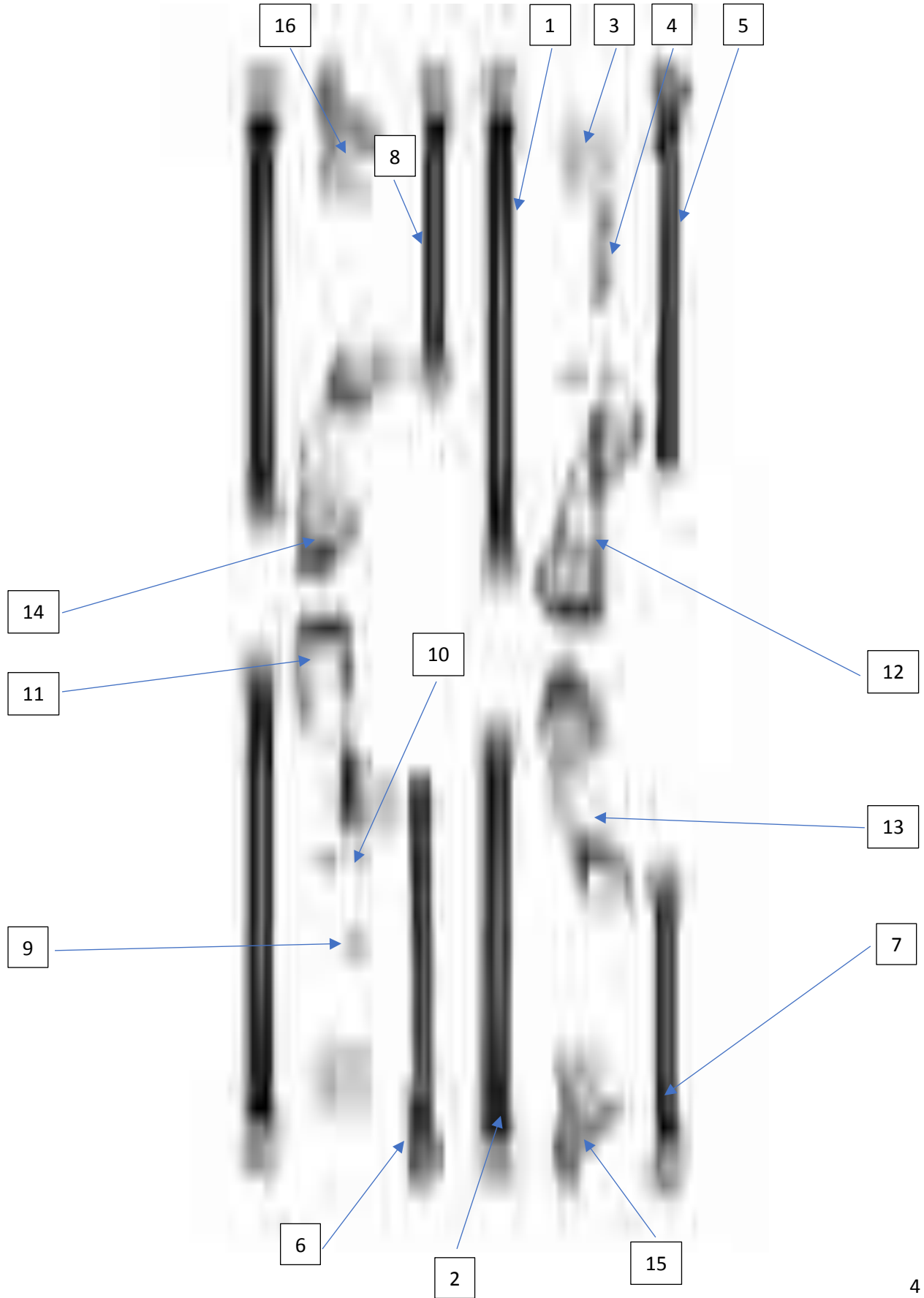



#### **Recommended Tools:**

- Welder and materials
  - Drill/ Metal hole saw
  - Wrench/Impact with sockets
  - Grinder/Cutting tool
- 



#### **Safety Steps for installation**

- For installing EVO MFG products always use wheel chokes to block rear tires from rolling.
  - Always make sure you have everything necessary ready before install.
  - If you have to, carefully lift front of vehicle by front frame rails extending suspension until tires leave the ground, place frame on approved jack stands for vehicle. Verify all lines/wires are not over extended.
  - Remove tires if needed for easier install.
  - Make sure to wear safety equipment (eye protection, hand protection, foot protection etc.) at all times during installation.
  - Make sure all safety precautions have been taken.
  - Always check and replace any part of vehicle that is worn or broken before starting install.
  - Do not mix anything EVO with weaker alternatives.
  - It is generally a good idea to apply liquid threadlock to all bolts.
  - Tighten included hardware to torque specifications in bottom table unless it is otherwise specified, factory bolts should be torqued to factory Jeep specifications.
- 





## **INSTALL**

1. Carefully lift vehicle by frame rails/crossmember extending the suspension until the tires leave the ground.
2. Securely place weight approved jack stands for vehicle under frame

**With vehicle tires now suspended and frame securely supported on stands, remove tires from vehicle.**





1. Remove both driver and passenger side swaybar links bolts at axle and swaybar removing swaybar links and rotate sway up and out of the way. Factory front links will not be reused.
- 

**There is a 6mm allen key inside both driver and passenger side upper sway bar studs. Use allen head to allow nut to unscrew.**

3. Remove bolt on brake line bracket.
- 



4. Disconnect push-in clip from front upper control arm mounts at axle holding wire. Un clip all other wires/hoses that are connected to axle.
- 

**Vehicle wiring and hoses vary, make sure all wires, hoses, lines etc. from frame to axle are freed up giving ample length to move axle downward as needed before proceeding, verify wiring/hoses etc. do not get stretched while lowering axle in next steps.**

---



**Support BOTH axles with jack stands**

5. **IF** you are **replacing shocks** and not using shock extensions remove upper bolt. Otherwise leave shock mounted at upper.
6. Lightly jack the front driver side axle tube slightly. With axle slightly supported remove front lower shock bolt from axle.
7. Repeat on passenger side.

**Varying axle jack tension to the right amount will alleviate load on the bolt and allow it to freely slide out.**

---





8. Remove trackbar bolt at both axles.

**This will allow the axle to move side to side so be cautious about this from here on.**



9. Unbolt driveshaft from axle. Tie up and out of the way.

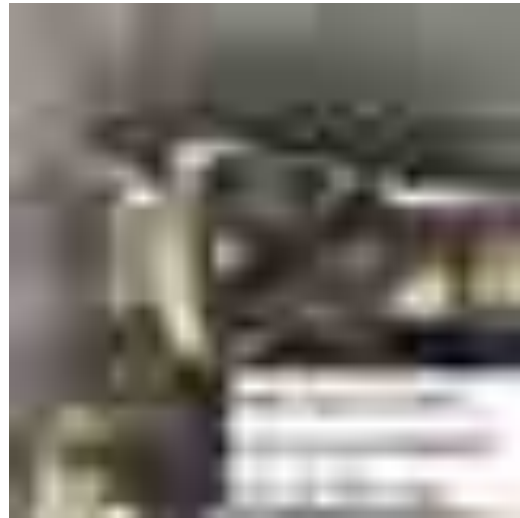

10. To lower the axle without any binding, we will remove the factory lower front control arms. Remove the driver side first, then remove the passenger side.

Repeat on rear arms.

**Be careful when removing control arms. Axle may rotate downward due to off centered weight, support pinion if necessary.**







11. Lower both front and rear axles (one at a time) while checking wire and hose lengths until springs can be removed.

Adjust wire and hose connections as needed.

12. Remove springs

---



13. Remove upper control arms from frame and axle and set aside. Axle will be loose at this time use caution and appropriate support.

Repeat on rear arms.

Be careful when removing control arms. Axle may rotate downward due to off centered weight, support pinion if necessary.

---



14. Carefully Support underside of gas tank. Remove all bolts holding it to chassis. Carefully lower tank (remember there is fuel BE CAREFUL) until you can reach connections on top of tank and disconnect. Set tank aside in a safe well vented space away from any flames/heat. It will be reinstalled later.

---





15. Remove exhaust crossover bar from chassis (small crossmember bar in front of exhaust crossover), Bar will not be reused. Keep hardware.

---



16. Using tools at your disposal, grinders, cut off wheels, torch, plasma cutter etc. Clearance all control arm mounts, front upper, lower and rear upper and lower clean to frame rails.

---





17. At exhaust collector, remove bolt on frame side of the collector and re-install opposite way (from front to back) through existing exhaust flange nut, tighten to snug. On rear side install supplied M8 nut.

---



18. Once all control arm mounts are clearance clean to frame. Starting in the front install front driver long arm bracket to frame using the single bolt hole on the underside of the frame, where exhaust bar was once bolted, using original factory bolt. This will locate this bracket in the proper location. Slight clearance of edge/lip on exhaust collector may be required. Do so as needed.

---



Repeat previous step on passenger side (less exhaust note)

---

19. EVO-3010 3.6L GAS Models Only.  
On driver side front only, lower arm mounting hole will need to be drilled through frame. Mark center using bracket as template and drill through both sides frame using a drill similar in size to your hole saw centering drill bit (~1/4" drill). Bracket may need to be removed to drill. Be careful to keep drill as square and centered while drilling outer frame material. **EVO-3010D: DIESEL/392 KIT Will OMIT THIS STEP.**

---





---

**20. EVO-3010 3.6L GAS Models Only.**

After center pilot hole is drilled on driver side through both sides of frame DRILL INSIDE HOLE ONLY with 5/8" drill

---

**EVO-3010D: DIESEL/392 KIT Will OMIT THIS STEP**



---

**21. EVO-3010 3.6L GAS Models Only.**

On outside of frame we need to make a relief hole to install nut and washer inside frame to newer lower control arm bolt. Using at 1" or larger hole saw and the previously drilled pilot hole make hole in OUTSIDE of frame ONLY.

---

**EVO-3010D: DIESEL/392 KIT Will OMIT THIS STEP.**



---

22. On rear, we need to trim some of the rear body mount bracket on frame just rearward of the body mount itself on driver/passenger sides. Use the EVO Long arm as a template and slowly trim and fit body mount bracket until bracket fits nicely against body mount bracket and lower hole on underside of frame line up to install bolt. Roughly the rear side of the body mount will need to be full trimmed and cleaned to frame ~1/2" rearward of body mount small bolt.





Weld front Brackets as shown. (not all areas are shown, **weld all points of connection between frame and brackets, top and bottom, front and back**)

Driverside: Red Lines for Reference



Passenger Side: Red lines for Reference





23. Remove small body mount nut that is located in front of both rear tires. Keep hardware, will be reinstalling body mount.

---



24. Fit bracket to frame on left and right of vehicle using the single factory bolt on lower side of frame. This bolt is the bracket locator on both left and right sides.





25. Once all brackets are fitted to frame and fitment is acceptable. Use clamps brackets to firmly hold brackets to frame before welding.

Tack then weld **ALL SEAMS, CONNECTIONS AND OPENINGS BETWEEN EVO BRACKETS AND FRAME.**

---

26. Reinstall body mount using factory hardware.

Avoid welding near transmission crossmember on front passenger bracket. Use picture as reference.

Pictured: Front passenger x2  
Rear driver x2

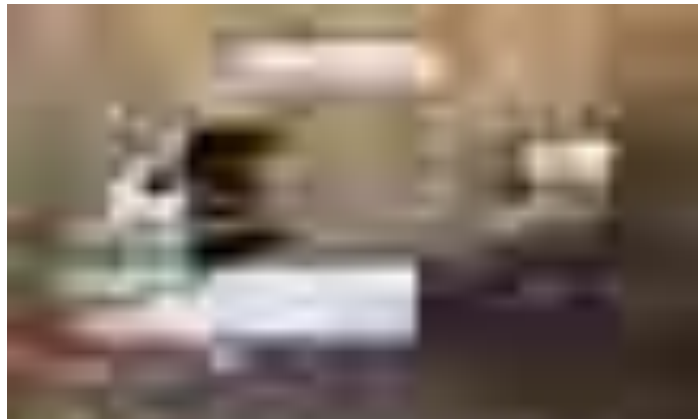





**IMPORTANT STEP:  
DO NOT MIS THIS STEP  
BOTH SIDES OF VEHICLE REAR FRAME  
BRACKETS**

With EVO MFG rear long arm bracket located at frame, install upper control arm gusset welding to body mount lip and upper control arm bracket corner. Reference red line when welding.

---



27. On rear axle, cleanly cut and grind smooth to axle tube the entire driver and passenger side rear lower control/shock mounts. Upper control arm mounts on axle will stay unmodified.

---

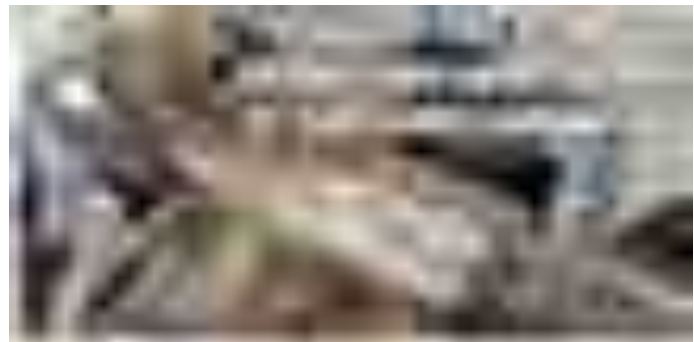



\*\*\* SEE BRACKET ASSEMBLY INSTRUCTIONS AT END OF THIS DOCUMENT. \*\*\*

28. Using the supplied EVO Rear Lower Control Arm mounts for the axle. Hold radius in bracket to axle tube. Notched front edge of EVO Bracket should be located flush with outer edge of axle bump stop pad. Shock tabs of each left and right side mount should be on the inside (not tire side). See photo. Trimming of bracket may be needed for parking brake cable clearance. Clearance as needed.
- 

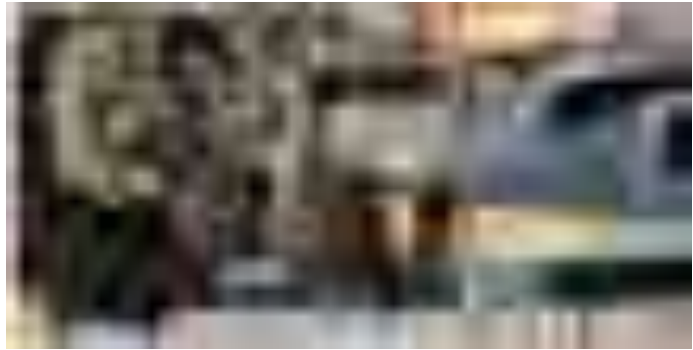
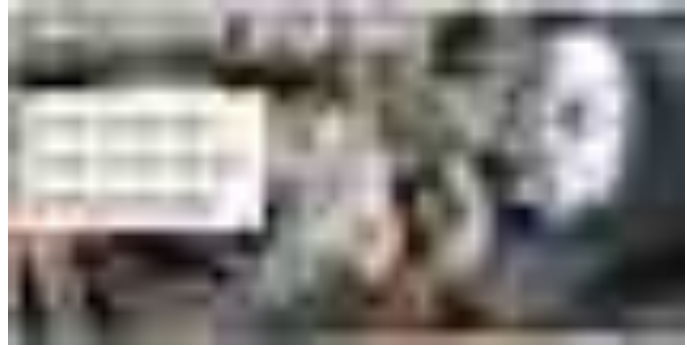

Once positioned, tack in place. Verify correct location of left and right and weld all connections to axle. Both sides.

Paint all bare surfaces.



29. After paint has dried. Install all control arms into their new mounting locations. Front upper arms will bend giving clearance around frame. Rear upper arms will bend giving clearance for tire.
30. Install all control arms with adjustable end at axle. All arms zero fittings and pinch bolts are recommend be on the up side during install.
31. Arms fully threaded in will be just slightly stretched of factory placement. Some stretch can be done by lengthening the arm thread out. Do not exceed 1" total on all arms. Cycle suspension to check for any interferences.

**ALL CONTROL ARM STARTING LENGTHS ARE LISTED AT THE BEGINNING OF THIS DOCUMENT.**

---





32. All hardware is reused at axle connection of control arms. Supplied hardware is used at frame connections. Install supplied 3/8" x 2" bolts on all 8 control arm pinch bolts. \*Front Lower will use 5/8" bolt washers and nut on driver side through drilled/hole sawed holes. 5/8" Bolt washer and large flag nut on Front Lower passenger side. \*Front upper will use supplied 4" x 9/16" bolt, washers and nut on both driver and passenger side frame.

---



33. Rear Lower will use supplied 4" x 9/16" bolt, washers and small flag nut on both driver and passenger side frame. \*Rear Upper will use supplied 3.5" x 9/16" bolt, washer and small flag nut on both driver and passenger side frame.

---





34. Reinstall new arms at axle locations using factory or upgraded hardware.

---

Verify all wiring and hoses are connected and have enough freedom for suspension motion.



35. Reinstall gas tank (Carefully)

Make sure all hoses and wires are properly connected, make sure there are no leaking fluids. Check and make sure all gauges read properly.

---





**Reinstall wheels and tires, lower to ground.**

Once vehicle is on the ground, set pinion angle on vehicle so that the driveshaft and the pinion are inline with the axle at an approximate ride height and centered to vehicle.



**RECENTER STEERINGWHEEL/FUNCTION CHECKS:**

Adjusting Turn buckle on Draglink. Make sure to turn the correct way to center (do not do a full rotation of steering wheel, closest direction to straight, watch wheel while turning) and pinch nuts once straight. You may need to do this more than once after a drive to get it straight to your liking. Test brakes and verify no leakage in lines before driving. Recheck often. Removal or trimming of factory plastic inner fender liner may be required to clear combinations of larger tire sizes and wheel back spacings. Check for acceptable clearance. Retorque all bolts after 500 miles.





#### After Install:

- Tighten all bolts securing purchased parts to specified locations.
- After completing installation using provided instructions, go through all steps again to make sure nothing was missed, not tightened or improperly assembled.
- Some components may need to be purchased separately.
- Check turn signals, headlights, fog lights (if applicable), taillights, blinkers and windshield wipers.
- Adjust mirrors, speedometer and headlights if needed.
- Make sure all gauges are fully operational.
- Drive the vehicle slowly for a couple minutes, looking and listening for abnormal noises while driving. After modification of a vehicle there will be differences in driving experiences and capabilities, be mindful of that.
- Inspect and Retorque all Bolts after 500 miles of completed installation and regularly thereafter.
- Some modification may be required.
- Test brakes and verify no leakage in lines before driving.

**PAINT MARK ALL TORQUED BOLTS. REGULARLY CHECK ALL BOLTS INCLUDING JAM NUT/PINCH BOLTS**

#### REAR LOWER AXLE CONTROL ARM/SHOCK MOUNT ASSEMBLY INSTRUCTIONS:

Assembly/tack/welding of the rear lower axle control bracket may be required. Follow the pictures below. First TACK in multiple locations on each component of each LEFT AND RIGHT Complete Assemblies.

VERIFY Control Arm Joints and Shock End will fit in each pocket.









Final weld all seams as shown.





Proceed back to above instruction on how to install on Factory Axle Housing



Recommended Torque:

Size	Grade 2		Grade 5		Grade 8		18-8 S/S	
	Coarse	Fine	Coarse	Fine	Coarse	Fine	Coarse	Fine
<b>#4*</b>	-	-	-	-	-	-	5.2	-
<b>#6*</b>	-	-	-	-	-	-	9.6	-
<b>#8*</b>	-	-	-	-	-	-	19.8	-
<b>#10*</b>	-	-	-	-	-	-	22.8	31.7
<b>1/4</b>	4	4.7	6.3	7.3	9	10	6.3	7.8
<b>5/16</b>	8	9	13	14	18	20	11	11.8
<b>3/8</b>	15	17	23	26	33	37	20	22
<b>7/16</b>	24	27	37	41	52	58	31	33
<b>1/2</b>	37	41	57	64	80	90	43	45
<b>9/16</b>	53	59	82	91	115	129	57	63
<b>5/8</b>	73	83	112	128	159	180	93	104
<b>3/4</b>	125	138	200	223	282	315	128	124
<b>7/8</b>	129	144	322	355	454	501	194	193
<b>1†</b>	188	210	483	541	682	764	287	289



EVO Manufacturing  
Jeep Wrangler JL Unlimited 2018+  
High Clearance Long Arm Kit Instruction Manual  
EVO-3010



**FOR 4 DOOR JLU MODELS ONLY**



Before starting installation procedure please read <http://evomfg.com>Returns-Warranties-Shipping>

**CAREFULLY READ AND FOLLOW ALL INSTRUCTIONS IN THIS MANUAL AND KEEP FOR FUTURE REFERENCE. IF YOU HAVE ANY QUESTIONS ABOUT THE PRODUCT CALL EVO MANUFACTURING. FAILURE TO FOLLOW GUIDELINES COULD RESULT IN MALFUNCTION OF PARTS OR INJURY. PLEASE HAVE A TRAINED PROFESSIONAL ASSIST WITH OR INSTALL ALL PRODUCTS. INSTALLING EVO MFG PRODUCTS OR KITS DEMANDS SPECIFIC KNOWLEDGE, TOOLS AND EXPERIENCE. GENERAL KNOWLEDGE OF HOW TO USE LATER SPECIFIED TOOLS AND/OR LIMITED EXPERIENCE WITH EVO MFG PRODUCTS MAY NOT BE ENOUGH TO PROPERLY COMPLETE THESE TASKS. SOME OF EVO MFG PRODUCTS MAY REQUIRE TWO OR MORE PEOPLE TO INSTALL SAFELY AND CORRECTLY. DO NOT ATTEMPT ALONE, ALWAYS ENLIST THE HELP OF TRAINED PROFESSIONAL WHEN NEEDED.**

**Notes: Set Up Before installation**

**This kit is compatible with 4 Door JL Unlimited Models Only.**

It requires cutting and grinding of frame mounts and welding of new bracketry.

Gas tank removal is required. This is easiest done when tank is low on fluid.

Wheel spacers or aftermarket wheels with a smaller backspacing than factory are required for a complete installation.

All Vehicles that spend time on salted roads. It is recommended that removal of control arm joint/collar (threaded end) on all control arms before installation of vehicle, apply a small amount of Anti Seize on threads and reassemble.

All factory bolts should be tightened to factory specifications. All supplied bolts torqued according to chart at end of instruction.

This instruction will give procedure of installing the long arm portion of the system first then return to install all other components after the vehicle has been long armed.

**DISCONNECT ALL BATTERY TERMINALS BEFORE STARTING. REINSTALL AT FINAL END OF INSTALLATION**

**Rough Starting lengths for all arms: Professional Alignment after installation recommend.**

<b>ARMS:</b>	<b>FRONT TRACKBAR:</b>	<b>REAR TRACKBAR:</b>
Front Uppers: 26 3/8"	2.5" Lift: 34 1/8"	2.5" Lift: 37 3/4"
Front Lower: 34 1/2"	3.5" Lift: 33 7/8"	3.5" Lift: 37 5/8"
Rear Uppers: 20 1/2"	4.5" Lift: 33 9/16"	4.5" Lift: 37 11/16"
Rear Lower: 30 1/2"		



**READ BEFORE INSTALL:**

It is generally a good idea to apply Loctite to all threaded bolts.

ALWAYS wear safety glasses and other approved safety gear when working on a vehicle.

All supplied bolts torqued according to chart at end of instruction.

It is recommended all installation be performed by a trained professional. Some modification may have to be done.

Test brakes and verify no leakage in lines before driving. Recheck often. Removal or trimming of factory plastic inner fender liner may be required to clear combinations of larger tire sizes and wheel back spacings.

Professional alignment is recommended after install.

**After alignment is complete and no additional adjustments are to be made to control arms. Torque all 1" Jam Nuts to 250 ft/lbs and all 1-1/4" Jam Nuts torque to 300 ft/lbs. Regularly check all jam nuts and punch bolts on all control arms for proper torque/tightness. Failure to do so may cause premature wear of threads on arms and is not covered under warranties.**

**SOME PART ASSEMBLY MAY BE REQUIRED. FOLLOW THESE ASSEMBLY INSTRUCTIONS AT END OF THIS DOCUMENT.**

**Parts included: Table below shows black (painted) EVO MFG JLU Long Arm Pro.**

Description	#	Part #	Quantity
EVO JL Fr Lower Long Arm Pair	1	EVO-12324B	2
EVO JL Rr Lower Long Arm Pair	2	EVO-11061B	2
JL HC Long Arm Hardware	3	EVO-770076	1
9/16-18 Flag Nut Straight Tab 1.5"	4	EVO-12031	4
EVO JL Front Upper LA Driver	5	EVO-11037B	1
EVO JL Front Upper LA Passenger	6	EVO-11038B	1
EVO JL Rear Upper LA Driver	7	EVO-11035B	1
EVO JL Rear Upper LA Passenger	8	EVO-11036B	1
5/8-18 Flag Nut Straight Tab 1.5"	9	EVO-12330	1
Misalignment Spacer 1" Heim 1/16" Bolt 2.625"	10	EVO-100563263	4
EVO JL Fr Driver LA Bracket	11	EVO-12320	1
EVO JL Fr Passenger LA Bracket	12	EVO-12321	1
EVO JL Rr Driver LA Bracket	13	EVO-12322	1
EVO JL Rr Passenger LA Bracket	14	EVO-12323	1
JL Lower Rr Axle LA Mount Dr	15	Unassembled	1
JL Lower Rr Axle LA Mount Pass	16	Unassembled	1

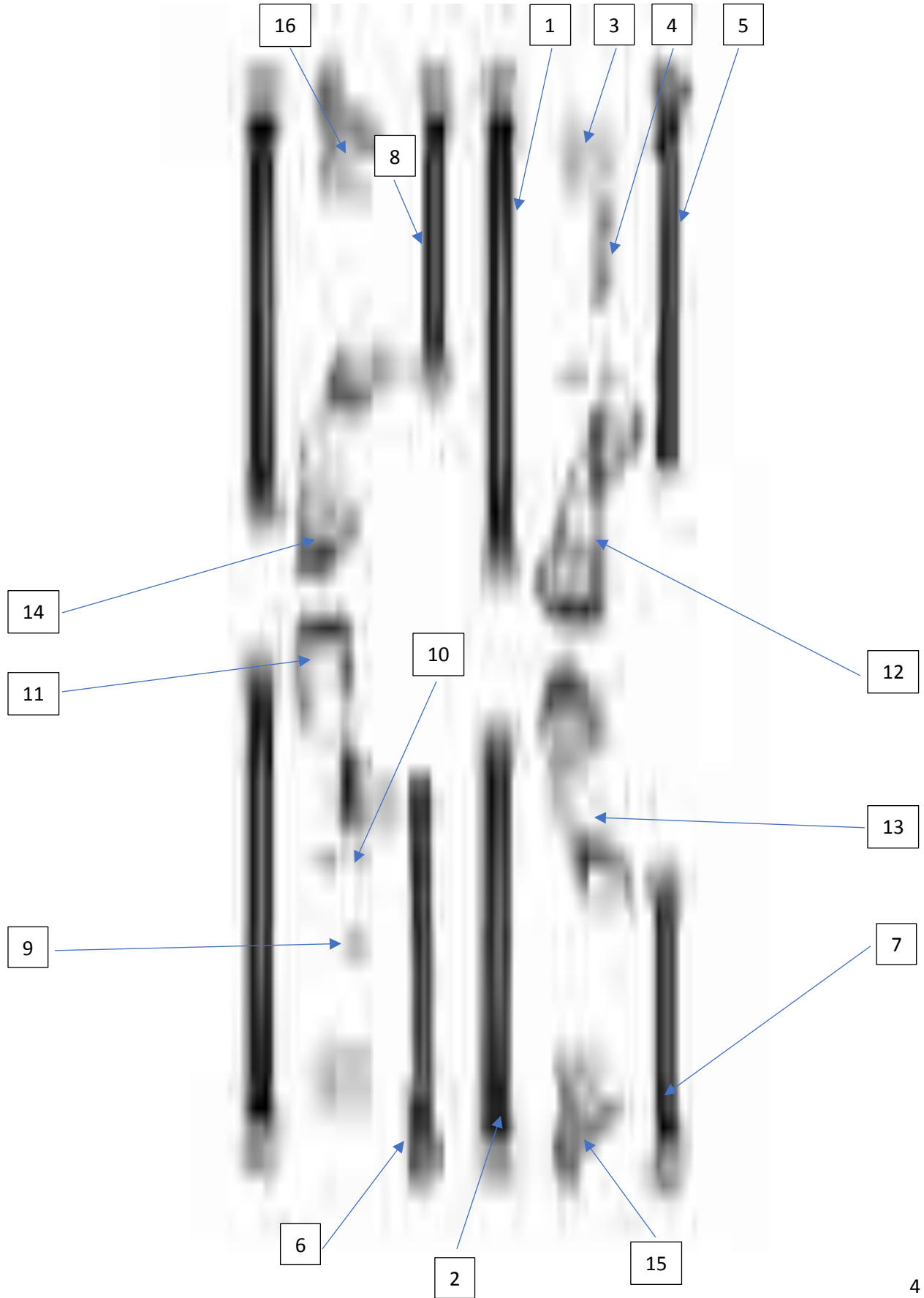



#### **Recommended Tools:**

- Welder and materials
  - Drill/ Metal hole saw
  - Wrench/Impact with sockets
  - Grinder/Cutting tool
- 



#### Safety Steps for installation

- For installing EVO MFG products always use wheel chokes to block rear tires from rolling.
  - Always make sure you have everything necessary ready before install.
  - If you have to, carefully lift front of vehicle by front frame rails extending suspension until tires leave the ground, place frame on approved jack stands for vehicle. Verify all lines/wires are not over extended.
  - Remove tires if needed for easier install.
  - Make sure to wear safety equipment (eye protection, hand protection, foot protection etc.) at all times during installation.
  - Make sure all safety precautions have been taken.
  - Always check and replace any part of vehicle that is worn or broken before starting install.
  - Do not mix anything EVO with weaker alternatives.
  - It is generally a good idea to apply liquid threadlock to all bolts.
  - Tighten included hardware to torque specifications in bottom table unless it is otherwise specified, factory bolts should be torqued to factory Jeep specifications.
- 







## **INSTALL**

1. Carefully lift vehicle by frame rails/crossmember extending the suspension until the tires leave the ground.
2. Securely place weight approved jack stands for vehicle under frame

**With vehicle tires now suspended and frame securely supported on stands, remove tires from vehicle.**





1. Remove both driver and passenger side swaybar links bolts at axle and swaybar removing swaybar links and rotate sway up and out of the way. Factory front links will not be reused.
- 

**There is a 6mm allen key inside both driver and passenger side upper sway bar studs. Use allen head to allow nut to unscrew.**

3. Remove bolt on brake line bracket.
- 



4. Disconnect push-in clip from front upper control arm mounts at axle holding wire. Un clip all other wires/hoses that are connected to axle.
- 

**Vehicle wiring and hoses vary, make sure all wires, hoses, lines etc. from frame to axle are freed up giving ample length to move axle downward as needed before proceeding, verify wiring/hoses etc. do not get stretched while lowering axle in next steps.**

---



**Support BOTH axles with jack stands**

5. **IF** you are **replacing shocks** and not using shock extensions remove upper bolt. Otherwise leave shock mounted at upper.
6. Lightly jack the front driver side axle tube slightly. With axle slightly supported remove front lower shock bolt from axle.
7. Repeat on passenger side.

**Varying axle jack tension to the right amount will alleviate load on the bolt and allow it to freely slide out.**

---





8. Remove trackbar bolt at both axles.

**This will allow the axle to move side to side so be cautious about this from here on.**



9. Unbolt driveshaft from axle. Tie up and out of the way.

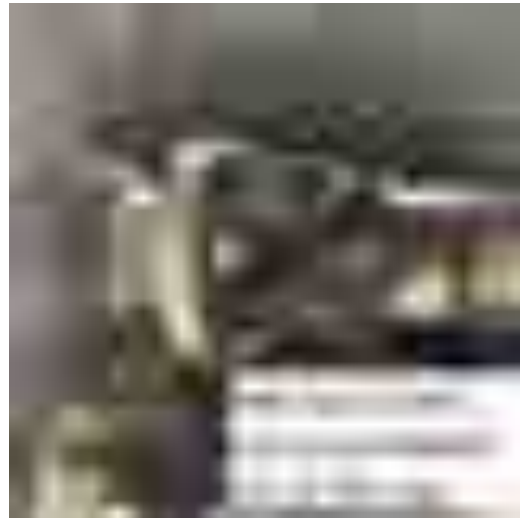

10. To lower the axle without any binding, we will remove the factory lower front control arms. Remove the driver side first, then remove the passenger side.

Repeat on rear arms.

**Be careful when removing control arms. Axle may rotate downward due to off centered weight, support pinion if necessary.**





11. Lower both front and rear axles (one at a time) while checking wire and hose lengths until springs can be removed.

Adjust wire and hose connections as needed.

12. Remove springs

---



13. Remove upper control arms from frame and axle and set aside. Axle will be loose at this time use caution and appropriate support.

Repeat on rear arms.

Be careful when removing control arms. Axle may rotate downward due to off centered weight, support pinion if necessary.

---



14. Carefully Support underside of gas tank. Remove all bolts holding it to chassis. Carefully lower tank (remember there is fuel BE CAREFUL) until you can reach connections on top of tank and disconnect. Set tank aside in a safe well vented space away from any flames/heat. It will be reinstalled later.

---





15. Remove exhaust crossover bar from chassis (small crossmember bar in front of exhaust crossover), Bar will not be reused. Keep hardware.

---



16. Using tools at your disposal, grinders, cut off wheels, torch, plasma cutter etc. Clearance all control arm mounts, front upper, lower and rear upper and lower clean to frame rails.

---





17. At exhaust collector, remove bolt on frame side of the collector and re-install opposite way (from front to back) through existing exhaust flange nut, tighten to snug. On rear side install supplied M8 nut.

---



18. Once all control arm mounts are clearance clean to frame. Starting in the front install front driver long arm bracket to frame using the single bolt hole on the underside of the frame, where exhaust bar was once bolted, using original factory bolt. This will locate this bracket in the proper location. Slight clearance of edge/lip on exhaust collector may be required. Do so as needed.

---



Repeat previous step on passenger side (less exhaust note)

---

19. EVO-3010 3.6L GAS Models Only.  
On driver side front only, lower arm mounting hole will need to be drilled through frame. Mark center using bracket as template and drill through both sides frame using a drill similar in size to your hole saw centering drill bit (~1/4" drill). Bracket may need to be removed to drill. Be careful to keep drill as square and centered while drilling outer frame material. **EVO-3010D: DIESEL/392 KIT Will OMIT THIS STEP.**

---





---

**20. EVO-3010 3.6L GAS Models Only.**

After center pilot hole is drilled on driver side through both sides of frame DRILL INSIDE HOLE ONLY with 5/8" drill

---

**EVO-3010D: DIESEL/392 KIT Will OMIT THIS STEP**



---

**21. EVO-3010 3.6L GAS Models Only.**

On outside of frame we need to make a relief hole to install nut and washer inside frame to newer lower control arm bolt. Using at 1" or larger hole saw and the previously drilled pilot hole make hole in OUTSIDE of frame ONLY.

---

**EVO-3010D: DIESEL/392 KIT Will OMIT THIS STEP.**



---

22. On rear, we need to trim some of the rear body mount bracket on frame just rearward of the body mount itself on driver/passenger sides. Use the EVO Long arm as a template and slowly trim and fit body mount bracket until bracket fits nicely against body mount bracket and lower hole on underside of frame line up to install bolt. Roughly the rear side of the body mount will need to be full trimmed and cleaned to frame ~1/2" rearward of body mount small bolt.





Weld front Brackets as shown. (not all areas are shown, **weld all points of connection between frame and brackets, top and bottom, front and back**)

Driverside: Red Lines for Reference



Passenger Side: Red lines for Reference







23. Remove small body mount nut that is located in front of both rear tires. Keep hardware, will be reinstalling body mount.

---



24. Fit bracket to frame on left and right of vehicle using the single factory bolt on lower side of frame. This bolt is the bracket locator on both left and right sides.





25. Once all brackets are fitted to frame and fitment is acceptable. Use clamps brackets to firmly hold brackets to frame before welding.

Tack then weld **ALL SEAMS, CONNECTIONS AND OPENINGS BETWEEN EVO BRACKETS AND FRAME.**

---

26. Reinstall body mount using factory hardware.

Avoid welding near transmission crossmember on front passenger bracket. Use picture as reference.

Pictured: Front passenger x2  
Rear driver x2

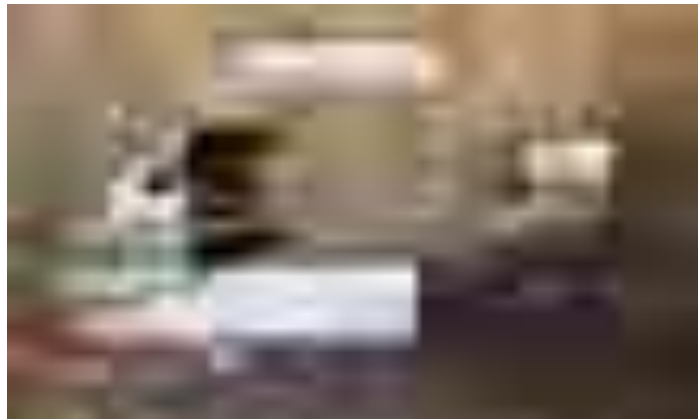
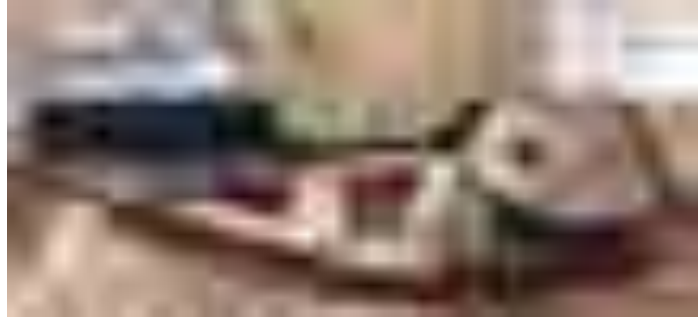



**IMPORTANT STEP:  
DO NOT MIS THIS STEP  
BOTH SIDES OF VEHICLE REAR FRAME  
BRACKETS**

With EVO MFG rear long arm bracket located at frame, install upper control arm gusset welding to body mount lip and upper control arm bracket corner. Reference red line when welding.

---



27. On rear axle, cleanly cut and grind smooth to axle tube the entire driver and passenger side rear lower control/shock mounts. Upper control arm mounts on axle will stay unmodified.

---

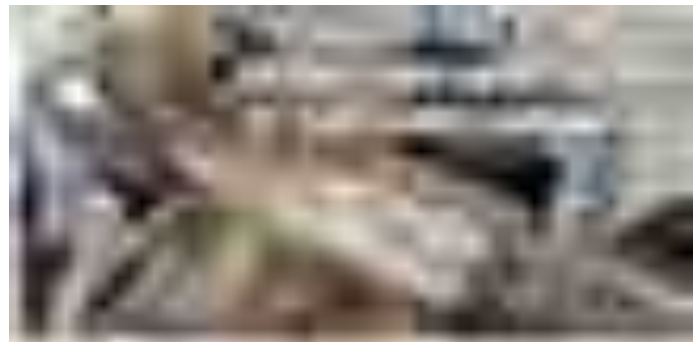



\*\*\* SEE BRACKET ASSEMBLY INSTRUCTIONS AT END OF THIS DOCUMENT. \*\*\*

28. Using the supplied EVO Rear Lower Control Arm mounts for the axle. Hold radius in bracket to axle tube. Notched front edge of EVO Bracket should be located flush with outer edge of axle bump stop pad. Shock tabs of each left and right side mount should be on the inside (not tire side). See photo. Trimming of bracket may be needed for parking brake cable clearance. Clearance as needed.
- 

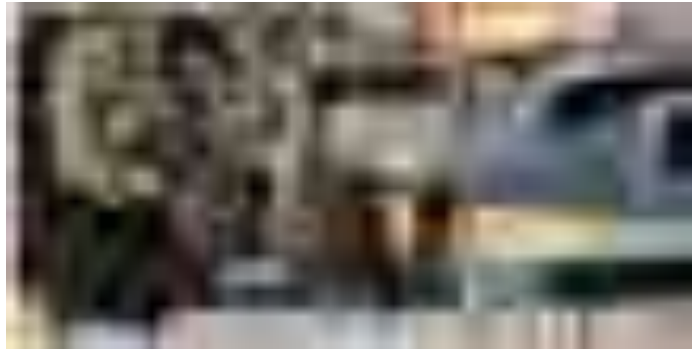
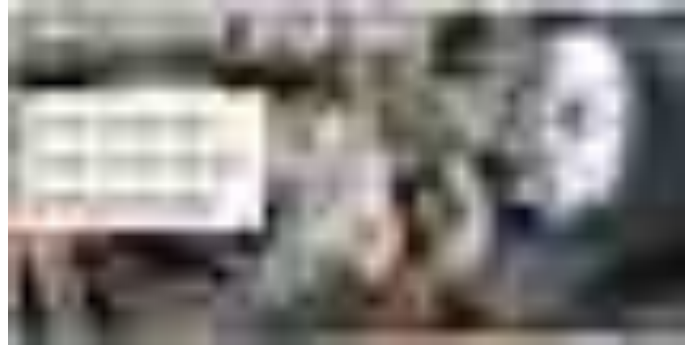

Once positioned, tack in place. Verify correct location of left and right and weld all connections to axle. Both sides.

Paint all bare surfaces.



29. After paint has dried. Install all control arms into their new mounting locations. Front upper arms will bend giving clearance around frame. Rear upper arms will bend giving clearance for tire.
30. Install all control arms with adjustable end at axle. All arms zero fittings and pinch bolts are recommend be on the up side during install.
31. Arms fully threaded in will be just slightly stretched of factory placement. Some stretch can be done by lengthening the arm thread out. Do not exceed 1" total on all arms. Cycle suspension to check for any interferences.

ALL CONTROL ARM STARTING LENGTHS ARE LISTED AT THE BEGINNING OF THIS DOCUMENT.





32. All hardware is reused at axle connection of control arms. Supplied hardware is used at frame connections. Install supplied 3/8" x 2" bolts on all 8 control arm pinch bolts. \*Front Lower will use 5/8" bolt washers and nut on driver side through drilled/hole sawed holes. 5/8" Bolt washer and large flag nut on Front Lower passenger side. \*Front upper will use supplied 4" x 9/16" bolt, washers and nut on both driver and passenger side frame.

---



33. Rear Lower will use supplied 4" x 9/16" bolt, washers and small flag nut on both driver and passenger side frame. \*Rear Upper will use supplied 3.5" x 9/16" bolt, washer and small flag nut on both driver and passenger side frame.

---





34. Reinstall new arms at axle locations using factory or upgraded hardware.

---

Verify all wiring and hoses are connected and have enough freedom for suspension motion.



35. Reinstall gas tank (Carefully)

Make sure all hoses and wires are properly connected, make sure there are no leaking fluids. Check and make sure all gauges read properly.

---







**Reinstall wheels and tires, lower to ground.**

Once vehicle is on the ground, set pinion angle on vehicle so that the driveshaft and the pinion are inline with the axle at an approximate ride height and centered to vehicle.



**RECENTER STEERINGWHEEL/FUNCTION CHECKS:**

Adjusting Turn buckle on Draglink. Make sure to turn the correct way to center (do not do a full rotation of steering wheel, closest direction to straight, watch wheel while turning) and pinch nuts once straight. You may need to do this more than once after a drive to get it straight to your liking. Test brakes and verify no leakage in lines before driving. Recheck often. Removal or trimming of factory plastic inner fender liner may be required to clear combinations of larger tire sizes and wheel back spacings. Check for acceptable clearance. Retorque all bolts after 500 miles.





#### After Install:

- Tighten all bolts securing purchased parts to specified locations.
- After completing installation using provided instructions, go through all steps again to make sure nothing was missed, not tightened or improperly assembled.
- Some components may need to be purchased separately.
- Check turn signals, headlights, fog lights (if applicable), taillights, blinkers and windshield wipers.
- Adjust mirrors, speedometer and headlights if needed.
- Make sure all gauges are fully operational.
- Drive the vehicle slowly for a couple minutes, looking and listening for abnormal noises while driving. After modification of a vehicle there will be differences in driving experiences and capabilities, be mindful of that.
- Inspect and Retorque all Bolts after 500 miles of completed installation and regularly thereafter.
- Some modification may be required.
- Test brakes and verify no leakage in lines before driving.

**PAINT MARK ALL TORQUED BOLTS. REGULARLY CHECK ALL BOLTS INCLUDING JAM NUT/PINCH BOLTS**

#### REAR LOWER AXLE CONTROL ARM/SHOCK MOUNT ASSEMBLY INSTRUCTIONS:

Assembly/tack/welding of the rear lower axle control bracket may be required. Follow the pictures below. First TACK in multiple locations on each component of each LEFT AND RIGHT Complete Assemblies.

VERIFY Control Arm Joints and Shock End will fit in each pocket.







Final weld all seams as shown.





Proceed back to above instruction on how to install on Factory Axle Housing



Recommended Torque:

Size	Grade 2		Grade 5		Grade 8		18-8 S/S	
	Coarse	Fine	Coarse	Fine	Coarse	Fine	Coarse	Fine
<b>#4*</b>	-	-	-	-	-	-	5.2	-
<b>#6*</b>	-	-	-	-	-	-	9.6	-
<b>#8*</b>	-	-	-	-	-	-	19.8	-
<b>#10*</b>	-	-	-	-	-	-	22.8	31.7
<b>1/4</b>	4	4.7	6.3	7.3	9	10	6.3	7.8
<b>5/16</b>	8	9	13	14	18	20	11	11.8
<b>3/8</b>	15	17	23	26	33	37	20	22
<b>7/16</b>	24	27	37	41	52	58	31	33
<b>1/2</b>	37	41	57	64	80	90	43	45
<b>9/16</b>	53	59	82	91	115	129	57	63
<b>5/8</b>	73	83	112	128	159	180	93	104
<b>3/4</b>	125	138	200	223	282	315	128	124
<b>7/8</b>	129	144	322	355	454	501	194	193
<b>1†</b>	188	210	483	541	682	764	287	289



EVO Manufacturing

2.5"/3.5" Jeep Wrangler JL 2018+

Enforcer Kit Instruction Manual

for all: EVO-3011, EVO-3012, EVO-3013, EVO-3014 Kits

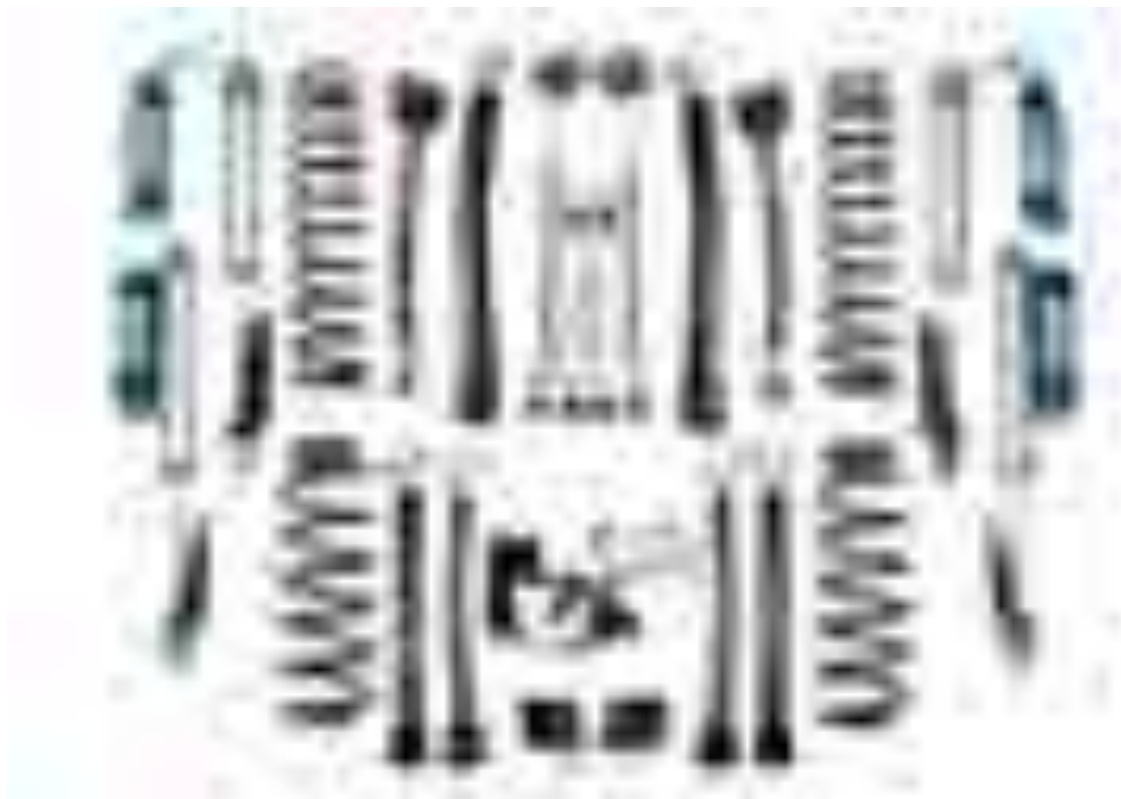

**READ BEFORE INSTALL:**

2.5" JL Enforcer/Enforcer Overland kits with either EVO shock extension kit or rear shocks 28.5" extended or less. These will work with factory wheels on Rubicon Models. Sahara and Sport models will require wheels spacers or aftermarket wheels with 5" or smaller number backspacing.

3.5" Enforcer/Enforcer Overland equipped JLs will require wheels spacers or aftermarket wheels with 4.5" or smaller number backspacing.

If installing EVO MFG Enforcer Control Arms: All Vehicles that spend time on salted roads. It is recommended that removal of control arm joint (threaded one) on all EVO control arms before installation of vehicle. Apply a small amount of Anti Seize on threads and reassemble. ALWAYS wear safety glasses and other approved safety gear when working on a vehicle. All factory bolts should be tightened to factory specifications. All supplied bolts torqued according to chart at end of instruction. Its is recommended all installation be performed by a trained professional. Safely and securely park vehicle on level ground with parking brake applied.

1. Use wheel chokes to block rear tires from rolling
2. Loosen all front and rear control arm and trackbar bolts at both axle and frame. DO NOT REMOVE (unless installing EVO Enforcer Arms). Just loosen a few turns to remove bolt compression on control arm bushings. If installing EVO Enforcer arms. Do so at this time. Remove and replace one arm at a time. **Keep bolts loose (installed but un-torqued) as described above. We will torque later at end of complete installation.**

**FRONT LOWER JL ENFORCER ARM STARTING LEGNTH CENTER TO CENTER 24 1/8"**

**FRONT UPPER JL ENFORCER ARM STARTING LEGNTH CENTER TO CENTER 20 1/4"**

**REAR LOWER JL ENFORCER ARM STARTING LEGNTH CENTER TO CENTER 19 3/4"**

**REAR UPPER JL ENFORCER ARM STARTING LEGNTH CENTER TO CENTER 17 1/2"**

	<b>2.5" Lift Coils</b>	<b>3.5" Lift Coils</b>
<b>Front Left Coil</b>	<b>600117</b>	<b>600113</b>
<b>Front Right Coil</b>	<b>600118</b>	<b>600114</b>
<b>Rear Left Coil</b>	<b>600119</b>	<b>600115</b>
<b>Rear Right Coil</b>	<b>600120</b>	<b>600116</b>

## **FRONT INSTALL**

3. Carefully lift front of vehicle by front frame rails extending suspension until tires leave the ground.
4. Securely place weight approved jack stands for vehicle under frame.
5. With vehicle front tires now suspended and frame securely supported on stands, remove front tires from vehicle.



6. Remove bolt from driver and pass side brake line bracket at frame just behind front coils.
7. Remove both driver and passenger side swaybar links bolts at axle and swaybar removing swaybar links and rotate sway up and out of the way. Factory front links will not be reused.
8. Disconnect push-in clip from front upper control arm mounts at axle holding wire.
9. **Vehicle wiring and hoses vary, make sure all wires, hoses, lines etc from frame to axle are freed up giving ample length to move axle downward as needed before proceeding, verify wiring/hoses etc do not get stretched while lowering axle in next steps.**
10. Lightly jack front driver side axle tube slightly. With axle slightly supported remove front lower shock bolt from axle. Varying axle jack tension to the right amount will alleviate load on the bolt and allow it to freely slide out. If you are replacing shocks and not using shock extensions remove upper bolt and remove shock. Otherwise leave shock mounted at upper. Support driver side axle with jack stand and repeat this step on passenger side.
11. Remove trackbar bolt at axle. This will allow the axle to move side to side so be cautious about this from here on.
12. Lower jack under axle giving room and remove front spring.
13. Insert supplied 3/8 x 2" bolt into front bumpstop extension. Place bumpstop with bolt inside (bore side up) EVO Front Coil spring and install coil spring with rubber isolator on top of coil into its original location on both the frame and axle. Axle may need to be lowered to install. Verify correct part number spring in correct location per table on previous page.



14. With spring in place and bumpstop extension sitting on axle pad and bolt inserted into bumpstop extension. Install supplied 3/8" nut from under spring pad to bolt inserted inside bumpstop extension and tighten.

#### OVERLAND KITS:



If you are installing Overland kit with Front Control Arm Relocation brackets. Follow these instruction: If not continue to next numbered step.

With axle and frame/vehicle safely supported. Loosen but do not remove bolt or nut on both upper and lower control bolts at their axle connections. Remove heat shield from upper control arm at frame and unbolt upper driver side upper control arm from frame. Unbolt lower control arm at frame **being very cautious and careful as the axle will no longer be connected to vehicle on the driver side at this time.** Rotate control arms out of the way and insert driver side control arm relocation brackets into frame pockets where control arms were once mounted. In both upper and lower arm location where bracket connects with frame insert supplied crush tube into gaps (shorter sleeve for upper mount and longer tube for lower mount). Use factory bolts to frame locations through EVO brackets and crush sleeves. Torque all frame bolts at EVO control arm brackets to factory specifications.

Rotate control arms back into their new location on the EVO Control arm relocation brackets. Use Supplied M12 bolt, washers and nut for upper control arm mount and 5/8 bolt, washers, nut for lower control arm mount.

15. Install front EVO brake line extension bracket at original brake line mounting location on frame with factory bolt.



16. Install factory brake line to the new lower location on the EVO brake line extension bracket. **Be very careful moving line into new location. The factory hardline will need to be slightly manipulated to be relocated. Do not use tools or pinch/crack the line.**



17. Reinstall shock at axle per factory specifications. If you are installing shock extensions. Do so at this time. Follow instructions for that kit. If you are installing new shocks, install shocks at both upper and lower mounting locations. Torque to factory specifications.

If new Front Lower EVO MFG Enforcer Arms have been installed. Carefully enlarge/drill brake line bracket mounting hole that once attached to factory lower arm to ½" and install on shock bolt after shock bolts have been torqued. Use M12 nut supplied with EVO Enforcer Control Arms. Series: Shock nut, brake line bracket, Flange Nut.

18. Repeat steps 10-19 on passenger side including Overland kit section is applicable.

19. Reinstall wheel and torque to factory specifications.

20. Carefully lift vehicle by frame, remove jack stands and lower to ground. When lowering be mindful of the front trackbar at axle this is not bolted in. It will need to be guided into it bracket at the axle while lowering the vehicle. When on the ground carefully turn steering

without ending running and in park with parking brake on and wheels chalked until trackbar lines up with hole in trackbar bracket. Insert factory bolt and loosely tighten bolt.

**21. Torque all control arm bolts, uppers, lowers at frame and axle. Torque all shock bolts at frame and axle. Torque front trackbar bolt. Check and torque all other bolts. Use chart below for supplied hardware. Use factory specifications for factory hardware.**

22. Front swaybar links should be left uninstalled at this time. We will install factory rear swaybar links on the front later in the process.

## REAR Install

23. Safely and securely park vehicle on level ground with parking brake applied.
24. Use wheel chokes to block front tires from rolling
25. While safely parked on ground. Loosen all rear control arm and trackbar bolts at both axle and frame. **DO NOT REMOVE** (unless installing EVO Enforcer Arms). Just loosen a few turns to remove bolt compression on control arm bushings. If installing EVO Enforcer arms. Do so at this time. Remove and replace one arm at a time. Keep bolts loose (installed but un-torqued) as described above.
26. Carefully lift rear of vehicle by frame rails/crossmember extending suspension until tires leave the ground.
27. Securely place weight approved jack stands for vehicle under frame
28. With vehicle rear tires now suspended and frame securely supported on stands, remove rear tires from vehicle.
29. Remove both driver and passenger side swaybar links bolts at axle and swaybar removing swaybar links and rotate sway up and out of the way.
30. **Vehicle wiring and hoses vary, make sure all wires, hoses, lines etc from chassis to axle are freed up giving ample length to move axle downward as needed before proceeding, verify**



**wiring/hoses etc do not get stretched while lowering axle in next steps.**

31. Lightly jack front driver side axle tube slightly. With axle slightly supported remove lower shock bolt from axle. Varying axle jack tension to the right amount will alleviate load on the bolt and allow it to freely slide out. If you are replacing shocks and not using shock extensions remove upper bolt and remove shock. Otherwise leave shock mounted at upper. Support driver side axle with jack stand and repeat this step on passenger side.
32. Lower jack under axle giving room and remove rear springs. Keep note of which spring is driver and passenger.
33. Install rear bump stop extensions to axle pads on both passenger and driver side axle pads using supplied 5/16" x .75 bolts, washers and nuts.
34. Install EVO Rear Coil spring and with factory rubber isolator on top of coil into the factory coil springs locations. Axle may need to be lowered to install. Verify correct part number spring in correct location per table page 2.
35. Repeat on passenger side



36. Assemble supplied rear swaybar links. Using light oil such as WD 40. Lubricate inner surface of link loops. Tap or vice in supplied rubber bushings. Lubricate inner surface of rubber bushings. Tap or vice in supplied swaybar tube sleeves.
37. With rear spring installed. Jack axle up until shock bolts line up with axle mounting holes. **Be very aware that vehicle does not lift off chassis/frame jack stands.** If you are installing new shocks or shock extensions, do so at this time. Follow factory torque specs for shock bolts.
38. Using 2 factory swaybar bolts and 2 supplied M12 x 60 bolts washers and nuts install assembled EVO swaybar links to axle on outside of swaybar tab and outside of swaybar itself (outside outside). Factory bolt at axle, supplied bolt at swaybar. Upper swaybar link bolt must be installed with bolt head at tire side and thread side at frame.
39. Depending on shock length you may need to disconnect parking brake cable from axle and route them below the frame crossmember. If the cables are limiting you down travel or a tight at full droop, route below crossmember and reconnect at axle.

FOR ENFORCER/ENFORCER OVERLAND 3.5" KIT ONLY. If installing 2.5" continue to next # step

Remove rear trackbar bolt at axle. Move trackbar down under/out of factory bracket. Swing trackbar above axle bracket. Slide EVO MFG Bracket over top of factory trackbar bracket while at same time inserting trackbar into the new higher location/pocket on the EVO Bracket. At lower original mounting location supplied crush sleeve into bracket and loosely install factory bolt at this location. Loosely Install supplied bolt at new trackbar location. Loosely install supplied U Bolt at axle tube. On driver side of bracket with bracket loosely installed, drill 15/32" hole through factory bracket. Install supplied 7/16" hardware. Torque all bracket bolts. Do not torque trackbar bolt at this time. This should be done one ground at ride height later.

40. Reconnect all disconnected hoses, wires etc.

41. Reinstall rear wheels
42. Carefully jack vehicle by frame and remove jack stands.
43. Lower vehicle to ground.
44. Install FACTORY REAR swaybar link onto the front axle and front sway. Rubber bushing side on factory link goes inside the two tabs on the front passenger side axle and stud mount to outside of swaybar. Bend in link should jog upwards moving studded end toward tire.
- 45. With vehicle park securely on level ground at ride height. Torque all control arm bolts, uppers, lowers at frame and axle. Torque all shock bolts at frame and axle. Torque front and rear trackbar bolts. Torque wheels. Check and torque all other bolts. Use chart below for supplied hardware. Use factory specifications for factory hardware. Double check everything is tight at this time.**

RECENTER STEERING WHEEL by Adjusting Turn buckle on Draglink. Make sure to turn the correct way to center (do not do a full rotation of steering wheel, closest direction to straight, watch wheel while turning) and tighten jam nut once straight. You may need to do this more than once after a drive to get it straight to your liking. Test brakes and verify no leakage in lines before driving. Recheck often. Removal or trimming of factory plastic inner fender liner may be required to clear combinations of larger tire sizes and wheel back spacings. Check for acceptable clearance. Retorque all bolts after 500 miles.

Size	Recommended Torque											
	Grade 2		Grade 5		Grade 8		18-8 S/S		Bronze		Brass	
	Coarse	Fine	Coarse	Fine	Coarse	Fine	Coarse	Fine	Coarse	Fine	Coarse	Fine
<b>#4*</b>	-	-	-	-	-	-	5.2	-	4.8	-	4.3	-
<b>#6*</b>	-	-	-	-	-	-	9.6	-	8.9	-	7.9	-
<b>#8*</b>	-	-	-	-	-	-	19.8	-	18.4	-	16.2	-
<b>#10*</b>	-	-	-	-	-	-	22.8	31.7	21.2	29.3	18.6	25.9
<b>1/4</b>	4	4.7	6.3	7.3	9	10	6.3	7.8	5.7	7.3	5.1	6.4
<b>5/16</b>	8	9	13	14	18	20	11	11.8	10.3	10.9	8.9	9.7
<b>3/8</b>	15	17	23	26	33	37	20	22	18	20	16	18
<b>7/16</b>	24	27	37	41	52	58	31	33	29	31	26	27
<b>1/2</b>	37	41	57	64	80	90	43	45	40	42	35	37
<b>9/16</b>	53	59	82	91	115	129	57	63	53	58	47	51
<b>5/8</b>	73	83	112	128	159	180	93	104	86	96	76	85
<b>3/4</b>	125	138	200	223	282	315	128	124	104	102	118	115
<b>7/8</b>	129	144	322	355	454	501	194	193	178	178	159	158
<b>1†</b>	188	210	483	541	682	764	287	289	265	240	235	212



EVO Manufacturing

2.5"/3.5"/4.5" Jeep Wrangler JL 2018+

Enforcer Kit Instruction Manual

EVO-3011, EVO-3012, EVO-3013, EVO-3014, EVO-3054, EVO-3055 Kits







Before starting installation procedure please read <http://evomfg.com>Returns-Warranties-Shipping>

**CAREFULLY READ AND FOLLOW ALL INSTRUCTIONS IN THIS MANUAL AND KEEP FOR FUTURE REFERENCE. IF YOU HAVE ANY QUESTIONS ABOUT THE PRODUCT CALL EVO MANUFACTURING. FAILURE TO FOLLOW GUIDELINES COULD RESULT IN MALFUNCTION OF PARTS OR INJURY. PLEASE HAVE A TRAINED PROFESSIONAL ASSIST WITH OR INSTALL ALL PRODUCTS. INSTALLING EVO MFG PRODUCTS OR KITS DEMANDS SPECIFIC KNOWLEDGE, TOOLS AND EXPERIENCE. GENERAL KNOWLEDGE OF HOW TO USE LATER SPECIFIED TOOLS AND/OR LIMITED EXPERIENCE WITH EVO MFG PRODUCTS MAY NOT BE ENOUGH TO PROPERLY COMPLETE THESE TASKS. SOME OF EVO MFG PRODUCTS MAY REQUIRE TWO OR MORE PEOPLE TO INSTALL SAFELY AND CORRECTLY. DO NOT ATTEMPT ALONE, ALWAYS ENLIST THE HELP OF TRAINED PROFESSIONAL WHEN NEEDED.**

**Notes: Set Up Before installation**

**FRONT LOWER JL ENFORCER ARM STARTING LEGNTH CENTER TO CENTER 24 1/8"**

**FRONT UPPER JL ENFORCER ARM STARTING LEGNTH CENTER TO CENTER 20 1/4"**

**REAR LOWER JL ENFORCER ARM STARTING LEGNTH CENTER TO CENTER 19 3/4"**

**REAR UPPER JL ENFORCER ARM STARTING LEGNTH CENTER TO CENTER 17 1/2"**

**Keep all mounting bolts loose (installed but not torqued) we will torque later at the end of complete installation**

**Front JL EVO MFG trackbar starting length: 34 1/4"**

**Rear JL EVO MFG trackbar starting length: 37 7/16"**

**3.5"/4.5" JL Lifts: Front Lower and Rear Upper Adjustable Control Arms and Front & Rear Adjustable Trackbars are required for proper alignment/install. These are included with Stage 3 and Stage 4 "PLUS" Kits. Do not exceed 36" extended length on front trackbar and 39.5" on rear trackbar.**

**For all Stage 4 lifts add 3/8" to all control arm measurements stated above. The measurements are starting measurements and not exact measurements for every vehicle, A professional alignment is recommended.**

**After alignment is complete and no additional adjustments are to be made to control arms. Torque all 1" Jam Nuts to 250 ft/lbs and all 1-1/4" Jam Nuts torque to 300 ft/lbs. Regularly check all jam nuts and punch bolts on all control arms for proper torque/tightness. Failure to do so may cause premature wear of threads on arms.**

**Loosely install trackbar bolts. Only tighten/torque trackbar bolts after vehicle is at ride height under its own weight. Never tighten when suspension is extended.**

**INSTALLING A FACTORY DRIVER SIDE LOWER COIL SEAT ON PASSENGER SIDE IS SUGGESTED IF PASSENGER COIL ARC IS PRESENT. THEY ARE AVAILABLE FROM MOPAR/JEEP DEALER Mopar Part #: 68342245AC**



Parts included: Table below shows black (painted) JT Rear Shock Extention.

“LEFT” IS USA DRIVER SIDE, “RIGHT” IS USA PASSENGER SIDE, DIESEL AND 392 USE “HD”

Description	#	Part # 2.5" lift	Part # 3.5" lift	Part # 4.5" Lift	Quantity
Front Left Coil	1	GAS 600117 HD 600142 4XE 600114	GAS 600113 HD 600161 4XE 600142	GAS 600142 HD 600164 4XE 600161	1
Front Right Coil	2	GAS 600118 HD 600142 4XE 600114	GAS 600114 HD 600161 4XE 600142	GAS 600143 HD 600164 4XE 600161	1
Rear Left Coil	3	GAS 600119 HD 600116 4XE 600144	GAS 600115 HD 600144 4XE 600145	GAS 600144 HD 600188 4XE 600188	1
Rear Right Coil	4	GAS 600120 HD 600116 4XE 600144	GAS 600116 HD 600144 4XE 600145	GAS 600145 HD 600188 4XE 600188	1
Front Upper Control Arms	5	12313B	12313B	12313B	2
Front Lower CA DRV,PASS	6	12314B,12315B	12314B,12315B	12314B,12315B	1/1
Rear Lower Control Arms	7	12066B	12066B	12066B	2
Rear Upper CA DRV,PASS	8	12068B,12069B	12068B,12069B	12068B,12069B	1/1
FRT Bilstein 5100	9	EVO-600121K	EVO-600121K	EVO-600121K	1 PAIR
FRT King 2.0" Shocks		EVO-600146	EVO-600146	EVO-600146	2
FRT King 2.5" Shocks		EVO-600190BIL	EVO-600190BIL	EVO-600190BIL	2
Rear Bilstein 5100	10	EVO-600123K	EVO-600123K	EVO-600123K	1 PAIR
Rear King 2.0" Shocks		EVO-600147	EVO-600147	EVO-600147	2
Rear King 2.5" Shocks		EVO-600191BIL	EVO-600191BIL	EVO-600191BIL	2
Sway Bar Links	11	12029B	12029B	12029B	2
Front Bump Stop	12	20045	20045 + 20046	20045 + 20046	2/2
Rear Bump Stop EXT	13	12311B	12312B	12313B	2
EVO Enforcer Hardware Kit	15/	770077	770077	770077	1
Sway Bar Bushings	16	600077	600077	600077	4
Sway Bar Sleeve	17	20032	20032	20032	4
Trackbar Hardware	18	n/a	770078	n/a	1
Rear TrackBar Bkt	19	n/a	12328B	12328B	1
Front Trackbar	20	EVO-3047B	EVO-3047B	EVO-3047B	1
Rear Trackbar	21	EVO-3048B	EVO-3048B	EVO-3048B	1
Overland Brackets	22	EVO-3003B	EVO-3003B	EVO-3003B	2



**READ BEFORE INSTALL:**

- For Overland Kits ONLY, Minor grinding/clearance of oe frame upper link bracket may be needed
- 2.5" JL Enforcer/Enforcer Overland kits with either EVO shock extension kit or shocks 28.5" extended or less. These will work with factory wheels on Rubicon Models.
- Sahara and Sport models will require wheels spacers or aftermarket wheels with 5" or smaller number backspacing.
- 3.5"/4.5" Enforcer/Enforcer Overland equipped JLs will require wheels spacers or aftermarket wheels with 5" or smaller number backspacing. **Also recommend kit Stages 2-4 for proper alignment/install**
- If installing EVO MFG Enforcer Control Arms: All Vehicles that spend time on salted roads. It is recommended that removal of control arm joint (threaded one) on all EVO control arms before installation of vehicle. Apply a small amount of Anti Seize on threads and reassemble.
- ALWAYS wear safety glasses and other approved safety gear when working on a vehicle.
- All factory bolts should be tightened to factory specifications.
- All supplied bolts torqued according to chart at end of instruction.
- It is recommended all installation be performed by a trained professional.
- Some modification may have to be done in order to fit preferred tire or tire brand.
- Minor grinding/clearance of oe frame upper link bracket may be needed.





#### **Recommended Tools:**

- Impact with socket set
  - Wrenches (English/metric)
  - Screwdriver
  - Vehicle jack
  - Jack stand
  - Drill and ½" bit
  - WD40
  - Rubber Mallet/Vice
  - Dremel/knife/shears
  - Thread lock
  - Vice grips
  - Grinder
- 



#### Safety Steps for installation

- For installing EVO MFG products always use wheel chokes to block rear tires from rolling.
  - Always make sure you have everything necessary ready before install.
  - If you have to, carefully lift front of vehicle by front frame rails extending suspension until tires leave the ground, place frame on approved jack stands for vehicle. Verify all lines/wires are not over extended.
  - Remove tires if needed for easier install.
  - Make sure to wear safety equipment (eye protection, hand protection, foot protection etc.) at all times during installation.
  - Make sure all safety precautions have been taken.
  - Always check and replace any part of vehicle that is worn or broken before starting install.
  - Do not mix anything EVO with weaker alternatives.
  - It is generally a good idea to apply liquid threadlock to all bolts.
  - Tighten included hardware to torque specifications in bottom table unless it is otherwise specified, factory bolts should be torqued to factory Jeep specifications.
- 





## **FRONT INSTALL**

1. Remove bolt from driver and passenger side brake line bracket at frame just behind front coils.
2. Remove both driver and passenger side swaybar links bolts at axle and swaybar removing swaybar links and rotate sway up and out of the way. Factory front links will not be reused.

---

**There is a 6mm allen key inside both driver and passenger side upper sway bar studs. Use allen head to allow nut to unscrew.**

---





3. Disconnect push-in clip from front upper control arm mounts at axle holding wire.

**Vehicle wiring and hoses vary, make sure all wires, hoses, lines etc. from frame to axle are freed up giving ample length to move axle downward as needed before proceeding, verify wiring/hoses etc. do not get stretched while lowering axle in next steps.**

---



#### **Support driver side axle with jack stand**

4. **IF** you are **replacing shocks** and not using shock extensions remove upper bolt. Otherwise leave shock mounted at upper.
5. Lightly jack the front driver side axle tube slightly. With axle slightly supported remove front lower shock bolt from axle.
6. Repeat on passenger side.

**Varying axle jack tension to the right amount will alleviate load on the bolt and allow it to freely slide out.**

---





7. Remove trackbar bolt at axle.

**This will allow the axle to move side to side so be cautious about this from here on.**

8. Lower jack under axle giving room and remove front spring.



9. Insert supplied 3/8 x 2" bolt into front bumpstop extension. Place bumpstop with bolt inside (bore side up) EVO Front Coil spring. Install coil spring with rubber isolator on top of coil into its original location on both the frame and axle.

**Axle may need to be lowered to install. Verify correct part number spring in correct location per table on page 3.**

10. With spring in place and bumpstop extension sitting on axle pad and bolt inserted into bumpstop extension. Install supplied 3/8" nut from under spring pad to bolt inserted inside bump stop extension and tighten







Note: Make sure factory coil seats stay in the factory locations, Left coil seat on the left and right on the right, etc. Also make sure that the rubber pins insert into holes on coil brackets.

---

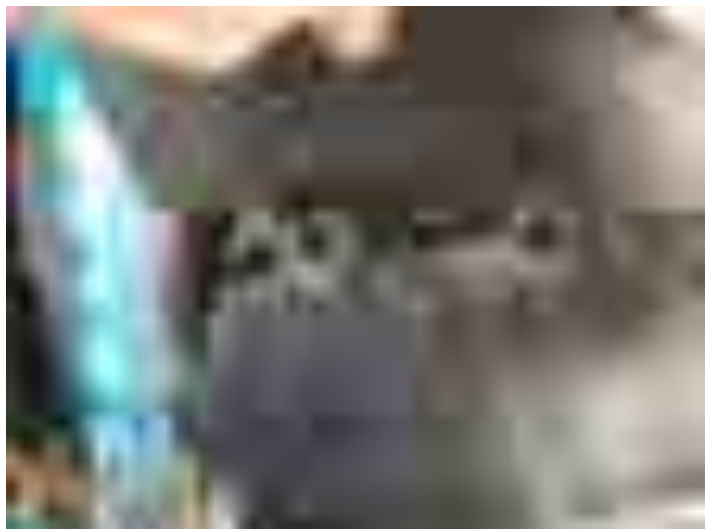



**Overland Kits ONLY:**

If you are installing Overland kit with Front Control Arm Relocation brackets. Follow these instruction: **If not continue to step 11.**

1. With axle and frame/vehicle safely supported. Loosen but do not remove bolt or nut on both upper and lower control arm bolts at their axle connections.
2. Remove heat shield from upper control arm at frame and unbolt driver side upper control arm from frame.
3. Unbolt lower control arm at frame **Being very cautious and careful as the axle will no longer be connected to vehicle on the driver side at this time.**
4. Rotate control arms out of the way and insert driver side control arm relocation brackets into frame pockets where control arms were once mounted. Factory frame upper link bracket may need to be slightly ground to line upper bolt hole.
5. In both upper and lower arm location where bracket connects with frame insert supplied crush tube into gaps (shorter sleeve for upper mount and longer tube for lower mount). Use factory bolts to frame locations through EVO brackets and crush sleeves.
6. Torque all frame bolts at EVO control arm brackets to factory specifications.
7. Rotate control arms back into their new location on the EVO Control arm relocation brackets. Use Supplied M12 bolt, washers and nut for upper control arm mount and 5/8 bolt, washers, nut for lower control arm mount.





11. Install front EVO brake line extension bracket at original brake line mounting location on frame with factory bolt.
12. Install factory brake line to the new lower location on the EVO brake line extension bracket.

**Carefully** move line down. Do not crimp/pinch line. Always check for leaking fluids and that brakes work correctly.

---



13. Reinstall shock at axle per factory specifications. If you are installing shock extensions. Do so at this time. Follow instructions for that kit. If you are installing new shocks, follow shock manufacturers specifications and install shocks at both upper and lower mounting locations. Torque to factory specifications.
- 





14. If new Front Lower EVO MFG Enforcer Arms have been installed. Use a 15mm wrench to remove the bracket that holds the brake line located on the factory lower control arm. Take the front brake line bracket, hold the top of the bracket right before the brake line with vice grips like the picture to the right. Follow the cut line that is shown (picture to the right) using a grinder/ cutting tool to remove excess brackets.

**Warning: DO NOT pinch/ cut/ tear/ pull/ twist etc the brake line.** After finishing cut, always check for leaking fluids and that brakes work correctly before operating vehicle. Periodically check thereafter.

Repeat steps 8-14 on passenger side including Overland kit section if applicable.

---



15. Reinstall wheels and torque to factory specifications. Carefully lift vehicle by frame, remove jack stands and lower to ground. **When lowering be mindful of the front trackbar at axle this is not bolted in.** It will need to be guided into the bracket at the axle while lowering the vehicle.

---





If installing new EVO MFG front trackbar, do so at this time to align/install trackbar bolt.

16. When on the ground carefully turn steering with engine running. Vehicle in park and with parking brake on and wheels chalked. Once trackbar lines up with hole in trackbar bracket, insert factory bolt and loosely tighten bolt.
- 



**While on ground under Jeeps own weight at ride height, torque all control arm bolts, uppers, lowers at frame and axle. Torque all shock bolts at frame and axle. Torque front trackbar bolt. Check and torque all other bolts. Use chart below for supplied hardware. Use factory specifications for factory hardware.**

**Front swaybar links should be left uninstalled at this time. We will install factory rear swaybar links on the front later in the process.**

## **REAR INSTALL:**

1. While safely parked on ground. Loosen all rear control arm and trackbar bolts at both axle and frame. **DO NOT REMOVE** (unless installing EVO Enforcer Arms). Just loosen a few turns to remove bolt compression on control arm bushings. If installing EVO Enforcer arms. Do so at this time. Remove and replace one arm at a time. Keep bolts loose (installed but un-torqued) as described above.
- 





2. Carefully lift rear of vehicle by frame rails/crossmember extending suspension until the tires leave the ground.
3. Securely place weight approved jack stands for vehicle under frame

**With vehicle rear tires now suspended and frame securely supported on stands, remove rear tires from vehicle.**



4. Remove both driver and passenger side swaybar links bolts at axle and swaybar removing swaybar links and rotate sway up and out of the way.

There is a 6mm allen key inside both driver and passenger side rear upper sway bar bolts. Tighten the allen head to allow nut to unscrew.





**Vehicle wiring and hoses vary, make sure all wires, hoses, lines etc from chassis to axle are freed up giving ample length to move axle downward as needed before proceeding, verify wiring/hoses etc do not get stretched while lowering axle in next steps.**

5. Lightly jack front driver side axle tube slightly. Support driver side axle with jack stand
6. With axle slightly supported remove lower shock bolt from axle.
7. Repeat this step on passenger side.

**Varying axle jack tension to the right amount will alleviate load on the bolt and allow it to freely slide out.**

**If you are replacing shocks and not using shock extensions remove upper bolt and remove shock. Otherwise leave shock mounted at upper.**

8. Lower jack under axle giving room and remove rear springs. Keep note of which spring is driver and passenger.
  9. Install rear bump stop extensions to axle pads on both passenger and driver side axle pads using supplied 5/16" x .75 bolts, washers and nuts.
  10. Install EVO Rear Coil spring and with factory rubber isolator on top of coil into the factory coil springs locations. Axle may need to be lowered to install. Verify correct part number spring in correct location per table page 2.
  11. Repeat on passenger side
- 





12. Assemble supplied rear swaybar links. Using light oil such as WD 40, lubricate inner surface of link loops. Tap or vice in supplied rubber bushings. Lubricate inner surface of rubber bushings. Tap or vice in supplied swaybar tube sleeves.

13. With rear spring installed. Jack axle up until shock bolts line up with axle mounting holes.

**Be very aware that vehicle does not lift off chassis/frame jack stands.**

14. If you are installing new shocks or shock extensions, do so at this time. Follow factory torque specs for shock bolts.



1. Lower swaybar and insert supplied EVO Swaybar drop brackets (1/2" hole tab should point toward the front of vehicle) between frame and swaybar dropping swaybar down. Use factory hardware to hold bracket to frame and supplied 3/8" hardware to mount swaybar to EVO bracket. Do so on both driver and passenger sides.







Depending on shock length you may need to disconnect parking brake cable from axle and route them below the frame crossmember. If the cables are limiting your down travel or are tight at full droop, route below crossmember and reconnect at axle. **Do NOT clip, pinch, tear, bend, or pull brake lines.** Always check for leaks, brake pressure and that brakes are working properly after manipulating brake lines.

### **FOR ENFORCER/ENFORCER OVERLAND 3.5"/4.5" KIT ONLY.**

1. Remove rear trackbar bolt at axle. Move trackbar down under/out of factory bracket. Swing trackbar above axle bracket.
  2. Slide square tab with single hole of EVO MFG Bracket INTO factory location of axle trackbar bracket while at same time inserting trackbar into the new higher location/pocket on the EVO Bracket.
- 



3. Place the supplied 5/8" washers as pictured prior to installing the trackbar bolts.
  4. One washer goes on the inside of the top forward most hole in between the trackbar and bracket.
  5. Second washer should go on the inside of the bottom rearmost hole between the factory bracket and EVO MFG bracket.
- 



There is a third washer in hardware bag if needed.

---



6. At lower original bolt mounting location, insert 5/8" spacer supplied crush sleeve into bracket and loosely install factory bolt at this location. Loosely install supplied bolt at new trackbar location. Loosely install supplied U Bolt at axle tube.
- 



7. On driver side of bracket with bracket loosely installed, drill 15/32" hole through factory bracket. Install supplied 7/16" hardware.
  8. Torque all bracket bolts. Do not torque trackbar bolt at this time. This should be done on the ground at ride height later.
- 





After install, set pinion angle on vehicle so that the driveshaft and the pinion are inline with the axle at an approximate right height and centered to vehicle.





### **Finishing up:**

1. Reconnect all disconnected hoses, wires etc.
2. Reinstall (all) rear wheels
3. Carefully jack vehicle by frame and remove jack stands.
4. Lower vehicle to ground.
5. Install FACTORY REAR swaybar link onto the front axle and front sway bar. Rubber bushing side on factory link goes inside the two tabs on the front passenger side axle and stud mount to outside of swaybar. Bend in link should jog upwards moving studded end toward tire.
6. **With vehicle parked securely on level ground at ride height. Torque all control arm bolts, uppers, lowers front and rear at frame and axle. Torque all shock bolts at frame and axle. Torque front and rear trackbar bolts. Torque wheels. Check and torque all other bolts. Use chart below for supplied hardware. Use factory specifications for factory hardware. Double check everything is tight at this time.**

RECENTER STEERING WHEEL by Adjusting Turn buckle on Draglink. Make sure to turn the correct way to center (do not do a full rotation of steering wheel, closest direction to straight, watch wheel while turning) and pinch nuts once straight. You may need to do this more than once after a drive to get it straight to your liking. Test brakes and verify no leakage in lines before driving. Recheck often. Removal or trimming of factory plastic inner fender liner may be required to clear combinations of larger tire sizes and wheel back spacings. Check for acceptable clearance. Retorque all bolts after 500 miles. **After alignment is complete and no additional adjusts are to be made to control arms. Torque all 1" Jam Nuts to 250 ft/lbs and all 1-1/4" Jam Nuts torque to 300 ft/lbs. Regularly check all jam nuts and punch bolts on all Enforcer control arms for proper torque/tightness. Failure to do so may cause premature wear of threads on arms.**





After Install:

- Tighten all bolts securing purchased parts to specified locations.
- After completing installation using provided instructions, go through all steps again to make sure nothing was missed, not tightened or improperly assembled.
- Some components may need to be purchased separately.
- Check turn signals, headlights, fog lights (if applicable), taillights, blinkers and windshield wipers.
- Adjust mirrors, speedometer and headlights if needed.
- Make sure all gauges are fully operational.
- Drive the vehicle slowly for a couple minutes, looking and listening for abnormal noises while driving. After modification of a vehicle there will be differences in driving experiences and capabilities, be mindful of that.
- For 3.5" or taller you will need a front track bar (included in plus "P" kit) or order EVO13047B separately.
- Inspect and Retorque all Bolts after 500 miles of completed installation and regularly thereafter.
- Some modification may be required.
- **Regularly check all jam nuts and punch bolts on all Enforcer control arms for proper torque/tightness. Failure to do so may cause premature wear of threads on arms.**

Recommended Torque:

Size	Grade 2		Grade 5		Grade 8		18-8 S/S	
	Coarse	Fine	Coarse	Fine	Coarse	Fine	Coarse	Fine
#4*	-	-	-	-	-	-	5.2	-
#6*	-	-	-	-	-	-	9.6	-
#8*	-	-	-	-	-	-	19.8	-
#10*	-	-	-	-	-	-	22.8	31.7
1/4	4	4.7	6.3	7.3	9	10	6.3	7.8
5/16	8	9	13	14	18	20	11	11.8
3/8	15	17	23	26	33	37	20	22
7/16	24	27	37	41	52	58	31	33
1/2	37	41	57	64	80	90	43	45
9/16	53	59	82	91	115	129	57	63
5/8	73	83	112	128	159	180	93	104
3/4	125	138	200	223	282	315	128	124
7/8	129	144	322	355	454	501	194	193
1+	188	210	483	541	682	764	287	289



EVO Manufacturing

2.5"/3.5" Jeep Wrangler JLU 2018+

High Clearance Long Arm Instruction Manual



	2.5" Lift Coils	3.5" Lift Coils
Front Left Coil	600117	600113
Front Right Coil	600118	600114
Rear Left Coil	600119	600115
Rear Right Coil	600120	600116

**READ BEFORE INSTALLATION: This kit is compatible with 4 Door JL Unlimited Models Only**

This kit is recommended to be installed by a trained installer. It requires cutting and grinding of frame mounts and welding of new bracketry. Gas tank removal is required. This is easiest done when tank is low on fluid. Wheel spacers or aftermarket wheels with a smaller backspacing than factory are required for a complete installation. All Vehicles that spend time on salted roads. It is recommended that removal of control arm joint/collar (threaded end) on all control arms before installation of vehicle, apply a small amount of Anti Seize on threads and reassemble. ALWAYS wear safety glasses and other approved safety gear when working on a vehicle. All factory bolts should be tightened to factory specifications. All supplied bolts torqued according to chart at end of instruction. This instruction will give procedure of installing the long arm portion of the system first then return to install all other components after the vehicle has been long armed. **DISCONNECT ALL BATTERY TERMINALS BEFORE STARTING. REINSTALL AT FINAL END OF INSTALLATION.**

Starting Length for all Long Arm:

Front Uppers: 26 3/8"

Rear Uppers: 20 1/2"

Front Lower: 34 1/2"

Rear Lower: 30 1/2"

1. Safely and securely park vehicle on level ground with parking brake applied.
2. Safely and securely lift vehicle on lift.
3. Remove Wheels and tires
4. Disconnect all wiring connections and hoses to axle.
5. Support axles and remove shocks
6. Remove bolt from driver and pass side brake line bracket at frame just behind front coils.
7. Remove both driver and passenger side swaybar links bolts at axle and swaybar removing swaybar links and rotate sway up and out of the way. Factory front links will not be reused.
8. Unbolt driveshaft from axle. Tie up and out of the way.
9. Lower axle while checking wire and hose lengths until springs can be removed. Adjust wire and hoses connections as needed
10. Remove springs
11. Remove control arms from frame and axle and set aside. Axle will be loose at this time use caution and appropriate support.
12. Carefully Support underside of gas tank. Remove all bolts holding it to chassis. Carefully lower tank (remember there is fuel BE CAREFUL) until you can reach connections on top of tank and disconnect. Set tank aside in a safe well vented space away from any flames/heat. It will be reinstalled later.
13. Remove exhaust crossover bar from chassis (small crossmember bar in front of exhaust crossover), Bar will not be reused. Keep hardware.
14. Using tools at your disposal, grinders, cut off wheels, torch, plasma cutter etc. Clearance all control arm mounts, front upper, lower and rear upper and lower clean to frame rail. All Factory control arm mounts removed.
15. At exhaust collector, remove bolt on frame side of the collector and re-install opposite way from front to back through existing exhaust flange nut, snug. On rear side install supplied M8 nut.





16. Once all control arm mounts are clearance clean to frame. Starting in the front install front driver long arm bracket to frame using the single bolt hole on the underside of the frame where exhaust bar once was bolted using original factory bolt. This will locate this bracket in the proper location. Slight clearance of edge/lip on exhaust collector may be required. Do so as needed.



17. Repeat previous step on passenger side (less exhaust note)

18. On driver side front only, lower arm mounting hole will need to be drilled through frame. Mark center using bracket as template and drill through both sides frame using a drill similar in size to you hole saw centering drill bit (~1/4" drill). Bracket may need



to be removed to drill. Be careful to keep drill as square and centered while drilling outside frame.

19. After center pilot hole is drilled on driver side through both sides of frame drill INSIDE HOLE ONLY with 5/8" drill
20. On outside of frame we need to make a relief hole to install nut and washer inside frame to newer lower control arm bolt. Using at 1" or larger hole saw and the previously drilled pilot hole make hole in OUTSIDE of frame ONLY.
21. On rear, we need to trim some of the rear body mount bracket on frame just rearward of the body mount itself on both sides. Use the EVO Long arm as a template and slowly trim and fit body mount bracket until bracket fits nicely against body mount bracket and lower hole on underside of frame line up to install bolt. Roughly the rear side of the body mount will need to be full trimmed and cleaned to frame ~1/2" back of body mount small bolt.



22. Once all brackets are fitted to frame and fitment is acceptable. Clamp brackets to frame where you can and weld all seams, connections and openings between EVO Brackets and Frame.
23. Onto rear axle lower control arm and shock mounts. On rear axle, cleanly cut and grind smooth to axle tube the entire driver and passenger side rear lower control/shock mounts.
24. Using the supplied EVO Rear Lower Control Arm mounts for the axle. Hold radius in bracket to axle tube. Notched front edge of EVO Bracket should be located flush with outer edge of axle bumpstop pad. Shock tabs should angle toward middle vehicle. See photo.



25. Once positioned, tab in place. Verify correct location of left and right and weld all connections to axle. Both sides.

26. Paint all exposed metal surfaces.



27. After paint has dried. Install all control arms into their new mounting locations. Front upper arms will bend giving clearance around frame. Rear upper arms will bend giving clearance for tire. Install all control arms with adjustable end at axle. All arms zerker fittings and pinch bolts are recommended to be on the up side during install. Arms fully threaded in will be just slightly stretched of factory placement. Some stretch can be done by lengthening the arm thread out. Do not exceed 1" total on all arms. Cycle suspension to check for any interferences. ALL CONTROL ARM STARTING LENGTHS ARE LISTED ON PAGE 2.

All hardware is reused at axle connection of control arms. Supplied hardware is used at frame connections. Install supplied 3/8" x 2" bolts on all 8 control arm pinch bolts.

\*Front Lower will use 5/8" bolt washers and nut on driver side through drilled/hole sawed holes. 5/8" Bolt washer and large flag nut on Front Lower passenger side.

\*Front upper will use supplied 4" x 9/16" bolt, washers and nut on both driver and passenger side frame.

\*Rear Lower will use supplied 4" x 9/16" bolt, washers and small flag nut on both driver and passenger side frame.

\*Rear Upper will use supplied 3.5" x 9/16" bolt, washer and small flag nut on both driver and passenger side frame.

28. Reinstall new arms at axle locations using factory or upgraded hardware.

29. Reinstall gas tank (Carefully)

## Front Coil and Components Install:

**30. Vehicle wiring and hoses vary, make sure all wires, hoses, lines etc from frame to axle are freed up giving ample length to move axle downward as needed before proceeding, verify wiring/hoses etc do not get stretched while lowering axle in next steps.**

31. Remove trackbar bolt at axle. This will allow the axle to move side to side so be cautious about this from here on.

32. Insert supplied 3/8 x 2" bolt into front bumpstop extension. Place bumpstop with bolt inside (bore side up) EVO Front Coil spring and install coil spring with rubber isolator on top of coil into its original location on both the frame and axle. Axle may need to be lowered to install. Verify correct part number spring in correct location per table on previous page.



33. With spring in place and bumpstop extension sitting on axle pad and bolt inserted into bumpstop extension. Install supplied 3/8" nut from under spring pad to bolt inserted inside bumpstop extension and tighten.



34. Install front EVO brake line extension bracket at original brake line mounting location on frame with factory bolt.



35. Install factory brake line to the new lower location on the EVO brake line extension bracket. **Be very careful moving line into new location. The factory hardline will need to be slightly manipulated to be relocated. Do not use tools or pinch/crack the line.**

36. Carefully enlarge/drill brake line bracket mounting hole that once attached to factory lower arm to 1/2" and install on shock bolt after shock bolts have been torqued. Use M12 nut supplied.

37. Reinstall shock at axle per factory specifications. If you are installing shock extensions. Do so at this time. Follow instructions for that kit. If you are installing new shocks, install shocks at both upper and lower mounting locations. Torque to factory specifications.

38. Reinstall wheel and torque to factory specifications.

39. Carefully lift vehicle by frame, remove jack stands and lower to ground. When lowering be mindful of the front trackbar at axle this is not bolted in. It will need to be guided into its bracket at the axle while lowering the vehicle. When on the ground carefully turn steering without ending running and in park with parking

brake on and wheels chalked until trackbar lines up with hole in trackbar bracket. Insert factory bolt and loosely tighten bolt.

**40. Torque all control arm bolts, uppers, lowers at frame and axle. Torque all shock bolts at frame and axle. Torque front trackbar bolt. Check and torque all other bolts. Use chart below for supplied hardware. Use factory specifications for factory hardware.**

41. Front swaybar links should be left uninstalled at this time. We will install factory rear swaybar links on the front later in the process.

## Rear Coil and Components Install:



42. Safely and securely park vehicle on level ground with parking brake applied.

43. Use wheel chokes to block front tires from rolling

44. While safely parked on ground. Loosen all rear control arm and trackbar bolts at both axle and frame. **DO NOT REMOVE** (unless installing EVO Enforcer Arms). Just loosen a few turns to remove bolt compression on control arm bushings. If installing EVO Enforcer arms. Do so at this time. Remove and replace one arm at a time. Keep bolts loose (installed but un-torqued) as described above.

45. Carefully lift rear of vehicle by frame rails/crossmember extending suspension until tires leave the ground.

46. Securely place weight approved jack stands for vehicle under frame

47. With vehicle rear tires now suspended and frame securely supported on stands, remove rear tires from vehicle.

48. Remove both driver and passenger side swaybar links bolts at axle and swaybar removing swaybar links and rotate sway up and out of the way.

**49. Vehicle wiring and hoses vary, make sure all wires, hoses, lines etc from chassis to axle are freed up giving ample length to move axle downward as needed before proceeding, verify wiring/hoses etc do not get stretched while lowering axle in next steps.**

50. Lightly jack front driver side axle tube slightly. With axle slightly supported

remove lower shock bolt from axle. Varying axle jack tension to the right amount will alleviate load on the bolt and allow it to freely slide out. If you are replacing shocks and not using shock extensions remove upper bolt and remove shock. Otherwise leave shock mounted at upper. Support driver side axle with jack stand and repeat this step on passenger side.

51. Lower jack under axle giving room and remove rear springs. Keep note of which spring is driver and passenger.
52. Install rear bump stop extensions to axle pads on both passenger and driver side axle pads using supplied 5/16" x .75 bolts, washers and nuts.
53. Install EVO Rear Coil spring and with factory rubber isolator on top of coil into the factory coil springs locations. Axle may need to be lowered to install. Verify correct part number spring in correct location per table page 2.
54. Repeat on passenger side



55. Assemble supplied rear swaybar links. Using light oil such as WD 40. Lubricate inner surface of link loops. Tap or vice in supplied rubber bushings. Lubricate inner surface of rubber bushings. Tap or vice in supplied swaybar tube sleeves.
56. With rear spring installed. Jack axle up until shock bolts line up with axle mounting holes. **Be very aware that vehicle does not lift off chassis/frame jack stands.** If you are installing new shocks or shock extensions, do so at this time. Follow factory torque specs for shock bolts.
57. Using 2 factory swaybar bolts and 2 supplied M12 x 60 bolts washers and nuts install assembled EVO swaybar links to axle on outside of swaybar tab and outside of swaybar itself (outside outside). Factory bolt at axle, supplied bolt at swaybar. Upper swaybar link bolt must be installed with bolt head at tire side and thread side at frame.
58. Install Shocks

59. Depending on shock length you may need to disconnect parking brake cable from axle and route them below the frame crossmember. If the cables are limiting you down travel or are tight at full droop, route below crossmember and reconnect at axle.

For Long Arm 3.5" Kits ONLY. If installing 2.5" kit continue to next # step

Remove rear trackbar bolt at axle. Move trackbar down under/out of factory bracket. Swing trackbar above axle bracket. Slide square tap with single hole of EVO MFG Bracket INTO factory location of axle trackbar bracket while at same time inserting trackbar into the new higher location/pocket on the EVO Bracket. At lower original bolt mounting location, insert supplied crush sleeve into bracket and loosely install factory bolt at this location. Loosely Install supplied bolt at new trackbar location. Loosely install supplied U Bolt at axle tube. On driver side of bracket with bracket loosely installed, drill 15/32" hole through factory bracket. Install supplied 7/16" hardware. Torque all bracket bolts. Do not torque trackbar bolt at this time. This should be done one ground at ride height later.





60. Reconnect all disconnected hoses, wires etc.
61. Reinstall rear wheels
62. Carefully jack vehicle by frame and remove jack stands.
63. Lower vehicle to ground.
64. Install **FACTORY REAR swaybar links** onto the **front axle and front swaybar**. Rubber bushing side on factory link goes inside the two tabs on the front passenger side axle and stud mount to outside of swaybar. Bend in link should jog upwards moving studded end toward tire.
65. **With vehicle park securely on level ground at ride height. Torque all control arm bolts, uppers, lowers at frame and axle. Torque all shock bolts at frame and axle. Torque front and rear trackbar bolts. Torque wheels. Check and torque all other bolts. Use chart below for supplied hardware. Use factory specifications for factory hardware. Double check everything is tight at this time.**
66. All 8 control arm pinch bolts should be tightened 40 lb/ft after alignment and before the vehicle is driven.



RECENTER STEERING WHEEL by Adjusting Turn buckle on Draglink. Make sure to turn the correct way to center (do not do a full rotation of steering wheel, closest direction to straight, watch wheel while turning) and tighten draglink pinch once straight. You may need to do this more than once after a drive to get it straight to your liking. Test brakes and verify no leakage in lines before driving. Recheck often. Removal or trimming of factory plastic inner fender liner may be required to clear combinations of larger tire sizes and wheel back spacings. Check for acceptable clearance. Alignment should be performed after installation by a trained professional with proper alignment equipment. Bring vehicle alignment specs to within factory recommendations. Retorque all bolts after 500 miles

Size	Recommended Torque					
	Grade 2		Grade 5		Grade 8	
	Coarse	Fine	Coarse	Fine	Coarse	Fine
<b>#4*</b>	-	-	-	-	-	-
<b>#6*</b>	-	-	-	-	-	-
<b>#8*</b>	-	-	-	-	-	-
<b>#10*</b>	-	-	-	-	-	-
<b>1/4</b>	4	4.7	6.3	7.3	9	10
<b>5/16</b>	8	9	13	14	18	20
<b>3/8</b>	15	17	23	26	33	37
<b>7/16</b>	24	27	37	41	52	58
<b>1/2</b>	37	41	57	64	80	90
<b>9/16</b>	53	59	82	91	115	129
<b>5/8</b>	73	83	112	128	159	180
<b>3/4</b>	125	138	200	223	282	315
<b>7/8</b>	129	144	322	355	454	501
<b>1†</b>	188	210	483	541	682	764



EVO Manufacturing

Jeep Wrangler JK/JL/JT Gladiator

JK/JL/JT Plush Ride Springs

EVO- 3021,3022,3023,3024,3052,3053,3068,3069,3076,3077,3078,3079,1074,1401,1402,1061,1062





Before starting installation procedure please read <http://evomfg.com>Returns-Warranties-Shipping>

**CAREFULLY READ AND FOLLOW ALL INSTRUCTIONS IN THIS MANUAL AND KEEP FOR FUTURE REFERENCE. IF YOU HAVE ANY QUESTIONS ABOUT THE PRODUCT CALL EVO MANUFACTURING. FAILURE TO FOLLOW GUIDELINES COULD RESULT IN MALFUNCTION OF PARTS OR INJURY. PLEASE HAVE A TRAINED PROFESSIONAL ASSIST WITH OR INSTALL ALL PRODUCTS. INSTALLING EVO MFG PRODUCTS OR KITS DEMANDS SPECIFIC KNOWLEDGE, TOOLS AND EXPERIENCE. GENERAL KNOWLEDGE OF HOW TO USE LATER SPECIFIED TOOLS AND/OR LIMITED EXPERIENCE WITH EVO MFG PRODUCTS MAY NOT BE ENOUGH TO PROPERLY COMPLETE THESE TASKS. SOME OF EVO MFG PRODUCTS MAY REQUIRE TWO OR MORE PEOPLE TO INSTALL SAFELY AND CORRECTLY. DO NOT ATTEMPT ALONE, ALWAYS ENLIST THE HELP OF TRAINED PROFESSIONAL WHEN NEEDED.**

**Notes: Set Up Before installation**

**All coils have a specific placement (front, back and left, right) on the vehicle, be sure to install in correct locations. Reference table below.**

**This is a general instruction for this component kit.**

**Directions/pictures may vary for each specific install, use for reference only.**

**Keep all mounting bolts loose (installed but not torqued) we will torque later at the end of complete installation**

**READ BEFORE INSTALL:**

It is generally a good idea to apply Loctite to all threaded bolts.

ALWAYS wear safety glasses and other approved safety gear when working on a vehicle.

All supplied bolts torqued according to chart at end of instruction.

It is recommended all installation be performed by a trained professional. Some modification may have to be done.

Paint all unfinished surfaces after install is complete.



Parts included: Table below shows JK/JL/JT Spring component kit.

Plush Ride Springs (pair)	#	Kit Part #	Driver / Passenger part #	Quantity
JL Front 2.5"	1	EVO-3021	600117 / 600118	1/1
JL Rear 2.5"	2	EVO-3022	600119, 600120	1/1
JL Front 3.5"	3	EVO-3023	600113, 600114	1/1
JL Rear 3.5"	4	EVO-3024	600115, 600116	1/1
JL Front 4.5"	5	EVO-3052	60142, 60143	1/1
JL Rear 4.5"	6	EVO-3053	60144, 60145	1/1
JT Front 2.5"	7	EVO-3068	600160, 600161	1/1
JT Rear 2.5"	8	EVO-3069	600162, 600163	1/1
JT Front 4.5"	9	EVO-3076	600164, 600165	1/1
JT Rear 4.5"	10	EVO-3077	600166, 600167	1/1
JT Front 6.5"	11	EVO-3078	600150, 600151	1/1
JT Rear 6.5"	12	EVO-3079	600152, 600153	1/1
JK Front 3"	13	EVO-1401	600075 (not side specific)	2
JK Rear 3"	14	EVO-1402	600076 (not side specific)	2
JK Front 4"	15	EVO-1061	600037 (not side specific)	2
JK Rear 4"	16	EVO-1062	600038 (not side specific)	2



#### **Recommended Tools:**

- Standard socket set w/ wrench
  - OR Standard wrench set
- 



#### **Safety Steps for installation**

- For installing EVO MFG products always use wheel chokes to block rear tires from rolling.
  - Always make sure you have everything necessary ready before install.
  - If you have to, carefully lift front of vehicle by front frame rails extending suspension until tires leave the ground, place frame on approved jack stands for vehicle. Verify all lines/wires are not over extended.
  - Remove tires if needed for easier install.
  - Make sure to wear safety equipment (eye protection, hand protection, foot protection etc.) at all times during installation.
  - Make sure all safety precautions have been taken.
  - Always check and replace any part of vehicle that is worn or broken before starting install.
  - Do not mix anything EVO with weaker alternatives.
  - It is generally a good idea to apply liquid threadlock to all bolts.
  - Tighten included hardware to torque specifications in bottom table unless it is otherwise specified, factory bolts should be torqued to factory Jeep specifications.
- 





1. Remove bolt from driver and passenger side brake line bracket at frame just behind front coils.
2. Remove both driver and passenger side swaybar links bolts at axle and swaybar removing swaybar links and rotate sway up and out of the way. Factory front links will not be reused.

---

**There is a 6mm allen key inside both driver and passenger side upper sway bar studs. Use allen head to allow nut to unscrew.**



---

JL/JT ONLY:

1. Disconnect push-in clip from front upper control arm mounts at axle holding wire. Un clip all other wires/hoses that are connected to axle.

**Vehicle wiring and hoses vary, make sure all wires, hoses, lines etc. from frame to axle are freed up giving ample length to move axle downward as needed before proceeding, verify wiring/hoses etc. do not get stretched while lowering axle in next steps.**





### **Support driver side axle with jack stand**

2. **IF** you are **replacing shocks** and not using shock extensions remove upper bolt. Otherwise leave shock mounted at upper.
3. Lightly jack the front driver side axle tube slightly. With axle slightly supported remove front lower shock bolt from axle.
4. Repeat on passenger side.

**Varying axle jack tension to the right amount will alleviate load on the bolt and allow it to freely slide out.**

---



5. Remove trackbar bolt at axle.

**This will allow the axle to move side to side so be cautious about this from here on.**

6. Lower jack under axle giving room and remove front spring.
- 





7. Install coil spring with rubber isolator on top of coil into its original location on both the frame and axle.

Replace all bolts or clips that were removed in the process.



After Install:

- Tighten all bolts securing purchased parts to specified locations.
- After completing installation using provided instructions, go through all steps again to make sure nothing was missed, not tightened or improperly assembled.
- Some components may need to be purchased separately.
- Check turn signals, headlights, fog lights (if applicable), taillights, blinkers and windshield wipers.
- Adjust mirrors, speedometer and headlights if needed.
- Make sure all gauges are fully operational.
- Drive the vehicle slowly for a couple minutes, looking and listening for abnormal noises while driving. After modification of a vehicle there will be differences in driving experiences and capabilities, be mindful of that.
- Inspect and Retorque all Bolts after 500 miles of completed installation and regularly thereafter.
- Some modification may be required.





Recommended Torque:

Size	Grade 2		Grade 5		Grade 8		18-8 S/S	
	Coarse	Fine	Coarse	Fine	Coarse	Fine	Coarse	Fine
<b>#4*</b>	-	-	-	-	-	-	5.2	-
<b>#6*</b>	-	-	-	-	-	-	9.6	-
<b>#8*</b>	-	-	-	-	-	-	19.8	-
<b>#10*</b>	-	-	-	-	-	-	22.8	31.7
<b>1/4</b>	4	4.7	6.3	7.3	9	10	6.3	7.8
<b>5/16</b>	8	9	13	14	18	20	11	11.8
<b>3/8</b>	15	17	23	26	33	37	20	22
<b>7/16</b>	24	27	37	41	52	58	31	33
<b>1/2</b>	37	41	57	64	80	90	43	45
<b>9/16</b>	53	59	82	91	115	129	57	63
<b>5/8</b>	73	83	112	128	159	180	93	104
<b>3/4</b>	125	138	200	223	282	315	128	124
<b>7/8</b>	129	144	322	355	454	501	194	193
<b>1†</b>	188	210	483	541	682	764	287	289



EVO Manufacturing

Jeep Wrangler JL

JL Raised Trackbar Mount

EVO- 3025B





Before starting installation procedure please read <http://evomfg.com>Returns-Warranties-Shipping>

---

**CAREFULLY READ AND FOLLOW ALL INSTRUCTIONS IN THIS MANUAL AND KEEP FOR FUTURE REFERENCE. IF YOU HAVE ANY QUESTIONS ABOUT THE PRODUCT CALL EVO MANUFACTURING. FAILURE TO FOLLOW GUIDELINES COULD RESULT IN MALFUNCTION OF PARTS OR INJURY. PLEASE HAVE A TRAINED PROFESSIONAL ASSIST WITH OR INSTALL ALL PRODUCTS. INSTALLING EVO MFG PRODUCTS OR KITS DEMANDS SPECIFIC KNOWLEDGE, TOOLS AND EXPERIENCE. GENERAL KNOWLEDGE OF HOW TO USE LATER SPECIFIED TOOLS AND/OR LIMITED EXPERIENCE WITH EVO MFG PRODUCTS MAY NOT BE ENOUGH TO PROPERLY COMPLETE THESE TASKS. SOME OF EVO MFG PRODUCTS MAY REQUIRE TWO OR MORE PEOPLE TO INSTALL SAFELY AND CORRECTLY. DO NOT ATTEMPT ALONE, ALWAYS ENLIST THE HELP OF TRAINED PROFESSIONAL WHEN NEEDED.**

**Notes: Set Up Before installation**

**This is a general instruction for this component kit.**

**Directions/pictures may vary for each specific install, use for reference only.**

**Keep all mounting bolts loose (installed but not torqued) we will torque later at the end of complete installation**

**READ BEFORE INSTALL:**

It is generally a good idea to apply Loctite to all threaded bolts.

ALWAYS wear safety glasses and other approved safety gear when working on a vehicle.

All supplied bolts torqued according to chart at end of instruction.

It is recommended all installation be performed by a trained professional. Some modification may have to be done.

Paint all unfinished surfaces after install is complete.



**Parts included: Table below shows black (painted) Rear Raised Trackbar Mount.**

Description	#	Part #	Quantity
Rear Raised Trackbar Mount	1	EVO-3025B	1



**Do not discard hardware pack.**



#### **Recommended Tools:**

- Impact with standard sockets
  - Drill + bits
- 



#### **Safety Steps for installation**

- For installing EVO MFG products always use wheel chokes to block rear tires from rolling.
  - Always make sure you have everything necessary ready before install.
  - If you have to, carefully lift front of vehicle by front frame rails extending suspension until tires leave the ground, place frame on approved jack stands for vehicle. Verify all lines/wires are not over extended.
  - Remove tires if needed for easier install.
  - Make sure to wear safety equipment (eye protection, hand protection, foot protection etc.) at all times during installation.
  - Make sure all safety precautions have been taken.
  - Always check and replace any part of vehicle that is worn or broken before starting install.
  - Do not mix anything EVO with weaker alternatives.
  - It is generally a good idea to apply liquid threadlock to all bolts.
  - Tighten included hardware to torque specifications in bottom table unless it is otherwise specified, factory bolts should be torqued to factory Jeep specifications.
- 





## **INSTALL**

On a flat surface, in park and wheels chalked.

1. Remove factory trackbar from factory axle bracket.





2. Insert EVO MFG Trackbar bracket into factory bracket, Use picture as reference.
- 

EVO bracket should sit on the inside of the factory brackets rearmost plate/face



3. Once inserted make sure axle tube bracket is in correct place, loosely install U-Bolt.
- 





4. Place the supplied 5/8" washers as pictured prior to installing the trackbar bolts.
  5. One washer goes on the inside of the top forward most hole in between the trackbar and bracket.
  6. Second washer should go on the inside of the bottom rearmost hole between the factory bracket and EVO MFG bracket.
- 

There is a third washer in hardware bag if needed.

---



7. Line up bolt holes on EVO MFG bracket with the factory bolt holes. Loosely install provided hardware through the brackets.
- 







8. Drill hole into factory bracket through EVO MFG bracket hole on driver side face of EVO MFG bracket. Install supplied hardware.
- 

Tighten all hardware to recommended torque.



After Install:

- Tighten all bolts securing purchased parts to specified locations.
- After completing installation using provided instructions, go through all steps again to make sure nothing was missed, not tightened or improperly assembled.
- Some components may need to be purchased separately.
- Check turn signals, headlights, fog lights (if applicable), taillights, blinkers and windshield wipers.
- Adjust mirrors, speedometer and headlights if needed.
- Make sure all gauges are fully operational.
- Drive the vehicle slowly for a couple minutes, looking and listening for abnormal noises while driving. After modification of a vehicle there will be differences in driving experiences and capabilities, be mindful of that.
- Inspect and Retorque all Bolts after 500 miles of completed installation and regularly thereafter.
- Some modification may be required.



Recommended Torque:

Size	Grade 2		Grade 5		Grade 8		18-8 S/S	
	Coarse	Fine	Coarse	Fine	Coarse	Fine	Coarse	Fine
<b>#4*</b>	-	-	-	-	-	-	5.2	-
<b>#6*</b>	-	-	-	-	-	-	9.6	-
<b>#8*</b>	-	-	-	-	-	-	19.8	-
<b>#10*</b>	-	-	-	-	-	-	22.8	31.7
<b>1/4</b>	4	4.7	6.3	7.3	9	10	6.3	7.8
<b>5/16</b>	8	9	13	14	18	20	11	11.8
<b>3/8</b>	15	17	23	26	33	37	20	22
<b>7/16</b>	24	27	37	41	52	58	31	33
<b>1/2</b>	37	41	57	64	80	90	43	45
<b>9/16</b>	53	59	82	91	115	129	57	63
<b>5/8</b>	73	83	112	128	159	180	93	104
<b>3/4</b>	125	138	200	223	282	315	128	124
<b>7/8</b>	129	144	322	355	454	501	194	193
<b>1+</b>	188	210	483	541	682	764	287	289



EVO Manufacturing

Jeep Wrangler JL

JL PROTEK Rear Shock Skids

EVO- 3026B





Before starting installation procedure please read <http://evomfg.com>Returns-Warranties-Shipping>

---

**CAREFULLY READ AND FOLLOW ALL INSTRUCTIONS IN THIS MANUAL AND KEEP FOR FUTURE REFERENCE. IF YOU HAVE ANY QUESTIONS ABOUT THE PRODUCT CALL EVO MANUFACTURING. FAILURE TO FOLLOW GUIDELINES COULD RESULT IN MALFUNCTION OF PARTS OR INJURY. PLEASE HAVE A TRAINED PROFESSIONAL ASSIST WITH OR INSTALL ALL PRODUCTS. INSTALLING EVO MFG PRODUCTS OR KITS DEMANDS SPECIFIC KNOWLEDGE, TOOLS AND EXPERIENCE. GENERAL KNOWLEDGE OF HOW TO USE LATER SPECIFIED TOOLS AND/OR LIMITED EXPERIENCE WITH EVO MFG PRODUCTS MAY NOT BE ENOUGH TO PROPERLY COMPLETE THESE TASKS. SOME OF EVO MFG PRODUCTS MAY REQUIRE TWO OR MORE PEOPLE TO INSTALL SAFELY AND CORRECTLY. DO NOT ATTEMPT ALONE, ALWAYS ENLIST THE HELP OF TRAINED PROFESSIONAL WHEN NEEDED.**

**Notes: Set Up Before installation**

**This is a general instruction for this component kit.**

**Directions/pictures may vary for each specific install, use for reference only.**

**Keep all mounting bolts loose (installed but not torqued) we will torque later at the end of complete installation**

**READ BEFORE INSTALL:**

It is generally a good idea to apply Loctite to all threaded bolts.

ALWAYS wear safety glasses and other approved safety gear when working on a vehicle.

All supplied bolts torqued according to chart at end of instruction.

It is recommended all installation be performed by a trained professional. Some modification may have to be done.

Paint all unfinished surfaces after install is complete.



Parts included: Table below shows black (painted) PROTEK Rear Shock Skids.

Description	#	Part #	Quantity
PROTEK Rear Shock Skids	1	EVO-3026B	2





**Recommended Tools:**

- Impact with standard sockets
  - OR wrench set
- 



**Safety Steps for installation**

- For installing EVO MFG products always use wheel chokes to block rear tires from rolling.
  - Always make sure you have everything necessary ready before install.
  - If you have to, carefully lift front of vehicle by front frame rails extending suspension until tires leave the ground, place frame on approved jack stands for vehicle. Verify all lines/wires are not over extended.
  - Remove tires if needed for easier install.
  - Make sure to wear safety equipment (eye protection, hand protection, foot protection etc.) at all times during installation.
  - Make sure all safety precautions have been taken.
  - Always check and replace any part of vehicle that is worn or broken before starting install.
  - Do not mix anything EVO with weaker alternatives.
  - It is generally a good idea to apply liquid threadlock to all bolts.
  - Tighten included hardware to torque specifications in bottom table unless it is otherwise specified, factory bolts should be torqued to factory Jeep specifications.
- 





## INSTALL

With vehicle on flat ground, in park with wheels chocked, remove lower bolts at shock bracket on axle.

---





1. Slide EVO Rear shock skid over axle bracket and loosely reinstall factory control arm bolt. Repeat on opposite side



After Install:

- Tighten all bolts securing purchased parts to specified locations.
- After completing installation using provided instructions, go through all steps again to make sure nothing was missed, not tightened or improperly assembled.
- Some components may need to be purchased separately.
- Check turn signals, headlights, fog lights (if applicable), taillights, blinkers and windshield wipers.
- Adjust mirrors, speedometer and headlights if needed.
- Make sure all gauges are fully operational.
- Drive the vehicle slowly for a couple minutes, looking and listening for abnormal noises while driving. After modification of a vehicle there will be differences in driving experiences and capabilities, be mindful of that.
- Inspect and Retorque all Bolts after 500 miles of completed installation and regularly thereafter.
- Some modification may be required.





Recommended Torque:

Size	Grade 2		Grade 5		Grade 8		18-8 S/S	
	Coarse	Fine	Coarse	Fine	Coarse	Fine	Coarse	Fine
<b>#4*</b>	-	-	-	-	-	-	5.2	-
<b>#6*</b>	-	-	-	-	-	-	9.6	-
<b>#8*</b>	-	-	-	-	-	-	19.8	-
<b>#10*</b>	-	-	-	-	-	-	22.8	31.7
<b>1/4</b>	4	4.7	6.3	7.3	9	10	6.3	7.8
<b>5/16</b>	8	9	13	14	18	20	11	11.8
<b>3/8</b>	15	17	23	26	33	37	20	22
<b>7/16</b>	24	27	37	41	52	58	31	33
<b>1/2</b>	37	41	57	64	80	90	43	45
<b>9/16</b>	53	59	82	91	115	129	57	63
<b>5/8</b>	73	83	112	128	159	180	93	104
<b>3/4</b>	125	138	200	223	282	315	128	124
<b>7/8</b>	129	144	322	355	454	501	194	193
<b>1+</b>	188	210	483	541	682	764	287	289



EVO Manufacturing

Jeep Wrangler JL/JT Gladiator

JL/JT PROTEK Front Shock Relocation

EVO- 3027B





Before starting installation procedure please read <http://evomfg.com>Returns-Warranties-Shipping>

---

**CAREFULLY READ AND FOLLOW ALL INSTRUCTIONS IN THIS MANUAL AND KEEP FOR FUTURE REFERENCE. IF YOU HAVE ANY QUESTIONS ABOUT THE PRODUCT CALL EVO MANUFACTURING. FAILURE TO FOLLOW GUIDELINES COULD RESULT IN MALFUNCTION OF PARTS OR INJURY. PLEASE HAVE A TRAINED PROFESSIONAL ASSIST WITH OR INSTALL ALL PRODUCTS. INSTALLING EVO MFG PRODUCTS OR KITS DEMANDS SPECIFIC KNOWLEDGE, TOOLS AND EXPERIENCE. GENERAL KNOWLEDGE OF HOW TO USE LATER SPECIFIED TOOLS AND/OR LIMITED EXPERIENCE WITH EVO MFG PRODUCTS MAY NOT BE ENOUGH TO PROPERLY COMPLETE THESE TASKS. SOME OF EVO MFG PRODUCTS MAY REQUIRE TWO OR MORE PEOPLE TO INSTALL SAFELY AND CORRECTLY. DO NOT ATTEMPT ALONE, ALWAYS ENLIST THE HELP OF TRAINED PROFESSIONAL WHEN NEEDED.**

**Notes: Set Up Before installation**

**Hardware is for JL/JT Front Shock Relocation brackets and JL Front Coilover kit. There will be remaining hardware if not installing Coilover kit.**

**This is a general instruction for this component kit.**

**Directions/pictures may vary for each specific install, use for reference only.**

**Keep all mounting bolts loose (installed but not torqued) we will torque later at the end of complete installation**

**READ BEFORE INSTALL:**

It is generally a good idea to apply Loctite to all threaded bolts.

ALWAYS wear safety glasses and other approved safety gear when working on a vehicle.

All supplied bolts torqued according to chart at end of instruction.

It is recommended all installation be performed by a trained professional. Some modification may have to be done.

Paint all unfinished surfaces after install is complete.



Parts included: Table below shows black (painted) PROTEK Front Shock Relocation Brackets.

Description	#	Part #	Quantity
PROTEK Front Shock Relocation Brackets	1	EVO-3027B	2



**Do not discard hardware pack.**



**Recommended Tools:**

- Impact with standard sockets
  - OR wrench set
- 



**Safety Steps for installation**

- For installing EVO MFG products always use wheel chokes to block rear tires from rolling.
  - Always make sure you have everything necessary ready before install.
  - If you have to, carefully lift front of vehicle by front frame rails extending suspension until tires leave the ground, place frame on approved jack stands for vehicle. Verify all lines/wires are not over extended.
  - Remove tires if needed for easier install.
  - Make sure to wear safety equipment (eye protection, hand protection, foot protection etc.) at all times during installation.
  - Make sure all safety precautions have been taken.
  - Always check and replace any part of vehicle that is worn or broken before starting install.
  - Do not mix anything EVO with weaker alternatives.
  - It is generally a good idea to apply liquid threadlock to all bolts.
  - Tighten included hardware to torque specifications in bottom table unless it is otherwise specified, factory bolts should be torqued to factory Jeep specifications.
- 





## INSTALL

1. With vehicle parked on flat ground, in park and wheels chalked. Remove lower shock bolt.
- 





2. Remove factory bolt holding brake line bracket to the coil mount, keep for reuse.
3. Remove enough of the plastic coil seat to allow bolt to go through bracket hole.

Keep brake line bracket in place, will reinstall bolt later in installation.



4. Place the EVO MFG bracket on the factory bracket and install the three supplied bolts and the factory bolt through the EVO MFG bracket.
5. The supplied bolts should be loosely installed with washers and nuts.

Repeat on other side, torque all bolts to specified torque.





After Install:

- Tighten all bolts securing purchased parts to specified locations.
- After completing installation using provided instructions, go through all steps again to make sure nothing was missed, not tightened or improperly assembled.
- Some components may need to be purchased separately.
- Check turn signals, headlights, fog lights (if applicable), taillights, blinkers and windshield wipers.
- Adjust mirrors, speedometer and headlights if needed.
- Make sure all gauges are fully operational.
- Drive the vehicle slowly for a couple minutes, looking and listening for abnormal noises while driving. After modification of a vehicle there will be differences in driving experiences and capabilities, be mindful of that.
- Inspect and Retorque all Bolts after 500 miles of completed installation and regularly thereafter.
- Some modification may be required.

Recommended Torque:

Size	Grade 2		Grade 5		Grade 8		18-8 S/S	
	Coarse	Fine	Coarse	Fine	Coarse	Fine	Coarse	Fine
#4*	-	-	-	-	-	-	5.2	-
#6*	-	-	-	-	-	-	9.6	-
#8*	-	-	-	-	-	-	19.8	-
#10*	-	-	-	-	-	-	22.8	31.7
1/4	4	4.7	6.3	7.3	9	10	6.3	7.8
5/16	8	9	13	14	18	20	11	11.8
3/8	15	17	23	26	33	37	20	22
7/16	24	27	37	41	52	58	31	33
1/2	37	41	57	64	80	90	43	45
9/16	53	59	82	91	115	129	57	63
5/8	73	83	112	128	159	180	93	104
3/4	125	138	200	223	282	315	128	124
7/8	129	144	322	355	454	501	194	193
1†	188	210	483	541	682	764	287	289





EVO Manufacturing

Jeep Wrangler JL/JLU and JT Gladiator

JL/JLU/JT Gladiator Front Bolt-on Coilover Kit

EVO- 3028B





Before starting installation procedure please read <http://evomfg.com>Returns-Warranties-Shipping>

---

**CAREFULLY READ AND FOLLOW ALL INSTRUCTIONS IN THIS MANUAL AND KEEP FOR FUTURE REFERENCE. IF YOU HAVE ANY QUESTIONS ABOUT THE PRODUCT CALL EVO MANUFACTURING. FAILURE TO FOLLOW GUIDELINES COULD RESULT IN MALFUNCTION OF PARTS OR INJURY. PLEASE HAVE A TRAINED PROFESSIONAL ASSIST WITH OR INSTALL ALL PRODUCTS. INSTALLING EVO MFG PRODUCTS OR KITS DEMANDS SPECIFIC KNOWLEDGE, TOOLS AND EXPERIENCE. GENERAL KNOWLEDGE OF HOW TO USE LATER SPECIFIED TOOLS AND/OR LIMITED EXPERIENCE WITH EVO MFG PRODUCTS MAY NOT BE ENOUGH TO PROPERLY COMPLETE THESE TASKS. SOME OF EVO MFG PRODUCTS MAY REQUIRE TWO OR MORE PEOPLE TO INSTALL SAFELY AND CORRECTLY. DO NOT ATTEMPT ALONE, ALWAYS ENLIST THE HELP OF TRAINED PROFESSIONAL WHEN NEEDED.**

**Notes: Set Up Before installation**

**This kit requires drilling and cutting of both metal and plastic.**

**Wheel backspacing adjustments may be required.**

**Cutting and Grinding required.**

**EVO MFG recommends this installation be performed by a trained professional.**

**Always use approved safety gear/glasses and weight approved jack/jack stands.**

**Keep all mounting bolts loose (installed but not torqued) we will torque later at the end of complete installation**

**READ BEFORE INSTALL:**

Re-torque all bolts after first 100 miles High Clearance Fenders recommended \*Re-torque all bolts every 3000 miles and after every off-road use.

It is generally a good idea to apply Loctite to all threaded bolts.

ALWAYS wear safety glasses and other approved safety gear when working on a vehicle.

All supplied bolts torqued according to chart at end of instruction.

It is recommended all installation be performed by a trained professional. Some modification may have to be done.

Paint all unfinished surfaces after install is complete.



Parts included: Table below shows JL/JLU/JT Gladiator Front Bolt-on Coilover Kit.

Description	#	Part #	Quantity
Coilover Tower Passenger	1	12335B	1
Coilover Tower Driver	2	12336B	1
Coilover Reservoir Mount	3	12342CZ	2
Bushing	4	600077	4
Sway Bar Bushing	5	20032	4
Sway Bar Link Front	6	12027B	2
Coilover Hardware	7	770079	1
Coilover Block Off Plate	8	12337	2
Crush Tube Front Coilover	9	20040CZ	4
Front Coilover Brake Line	10	12360CZ	2
Evo Front Bumper Spacer	11	20005	2
Passenger Front Lower Coilover Mount	12	12340B	1
Driver Front Lower Coilover Mount	13	12341B	1
Front Shock Relocation Hardware	14	770080	1
EVO Spec Coilover Front Pair	15	600124K	1





#### **Recommended Tools:**

- Allen set
  - Impact with standard sockets
  - Sawzall/Cut off wheel or similar
  - Drill
  - Parking break tool (recommended)
  - Rivet tool
- 



#### **Safety Steps for installation**

- For installing EVO MFG products always use wheel chokes to block rear tires from rolling.
  - Always make sure you have everything necessary ready before install.
  - If you have to, carefully lift front of vehicle by front frame rails extending suspension until tires leave the ground, place frame on approved jack stands for vehicle. Verify all lines/wires are not over extended.
  - Remove tires if needed for easier install.
  - Make sure to wear safety equipment (eye protection, hand protection, foot protection etc.) at all times during installation.
  - Make sure all safety precautions have been taken.
  - Always check and replace any part of vehicle that is worn or broken before starting install.
  - Do not mix anything EVO with weaker alternatives.
  - It is generally a good idea to apply liquid threadlock to all bolts.
  - Tighten included hardware to torque specifications in bottom table unless it is otherwise specified, factory bolts should be torqued to factory Jeep specifications.
- 





## **FRONT INSTALL**

After parking Jeep on a flat surface, chalk wheels and engage parking brake.

1. Carefully lift front of vehicle with jack by frame until tire leave the ground by a few inches minimum.
2. Carefully and securely set vehicle on weight approved jack stands. It is important that the vehicle is high enough that the tires are at least few inches from the ground as the axle will need to be lowered to remove and install parts.
3. Remove front wheels/tires.





- Carefully pull outward on grey clip at axle disconnect (FAD) until stops. It should move out about a 1/8". Then depress clip and disconnect clip/connection.
- 



- Rubicon Models: At differential, carefully pull outward on red clip at axle disconnect until it stops. It should move out about a 1/8". Then depress clip and disconnect clip/connection.
  - Remove breather hose from differential connection. **Vehicle wiring and hoses vary, make sure all wires, hoses, lines etc from frame to axle are freed up giving ample length to move axle downward as needed before proceeding, verify wiring/hoses etc do not get stretched while lowering axle during this installation.**
- 





7. Remove bolt from both driver and passenger side brake line bracket at axle on rear upper control arm bracket. Free bracket from its detent.
- 



8. Support axle with jacks and remove front sway bar end links from vehicle. (upper stud end on sway bar link has hex key on end of the stud to prevent rotation while removing nut).
- 





9. Remove both driver and passenger side shocks.

---



10. Lower axle until springs can be removed.  
Remove front springs and upper/lower coil isolators.

---







11. Insert coilover tower backing plate into pocket in tower. Align holes in tower with backing plate. Insert supplied 3/16" pop rivets. Using a rivet tool, complete rivet installation on both towers. If painting/color scheme the block off plate, do so before installing to towers. Holes may need to be clearance drilled with 3/16" bit.
- 





12. Mark cuts on frame side front shock mount as shown in photo. Using Sawzall, cut off wheel or other metal cutting tool, cut outer portion of front shock mount. Rear cut should be done through the middle of the bend in bracket leaving some of the factory bracket attached to frame. Do not remove all of rear portion. See photo of removed piece for reference. Sand all cut metal edges smooth. Paint exposed metal surfaces.
- 



13. Pry out on inner fender liner and install coilover tower behind liner into its mounting location on frame above factory coil mount and outside of trimmed factory shock mount.
  14. Loosely install 1/2" bolt washer and nut at forward most hole through frame coil mount and EVO tower.
  15. Using supplied crush tubes, reservoir mount and factory bolt, insert reservoir mount, 1 crush tube inside EVO tower and another crush tube on the inside side of tower.
  16. With factory bolt loosely install into original shock bolt location. At rear of tower where it mates with the frame, loosely install supplied 3/8" bolt, washer and nut in larger hole and 5/16" bolt washer and nut in smaller hole. These holes may need to be enlarged/drilled on the frame.
- 





17. With tower now loosely in place. Drill hole from underside on frame coil mount. Use supplied bolt washer and nut.

18. Tighten all tower bolts.

19. Trim inner fender liner to clear EVO Coilover tower bracket.

Repeat tower install steps on opposite side.





20. Using supplied 3/8" x 2" bolt, washers and nut. Install EVO front bumpstop extensions on the top side of the axle coil mount. Insert bolt from top down. Repeat on opposite side.

21. Install supplied shock mounts and brake line extension bracket at axle. Use supplied hardware at axle locations and factory bolt at relocated higher location for brake line.

22. Using supplied M12 hardware install shock into new lower mounting location using factory shock hardware.

Repeat on opposite side.



23. Clearance spring perch to the radius in bracket. Use white line in picture as placement reference for cutting.

---





24. Using supplied M12 bolt washers and nut, install coilover at upper tower mounting location.

Coilovers are side specific due to reservoir hose routing. Use photo to verify side.

25. Hose out of reservoir should point towards frame when in place.

26. Using supplied hose clamp and previously installed reservoir mount. Wrap clamp around reservoir body and through slots in mounting bracket. Insert end of hose clamp into screw end. Turn screw on hose clamp to tighten reservoir to tower.

27. Pivot reservoir into cleared portion of spring perch.

---



---

28. Reconnect all disconnected wiring and breather hoses. Verify adequate length of all wiring/hoses at full drop of suspension and adjust as needed.



29. Once vehicle is on ground under its own weight. Access lift requirement/adjustment needed (“I would like it 1” higher/lower”) If changes in lift need to be made. Carefully lift vehicle up by front frame until tires leave the ground, extending suspension fully and carefully set on jack stands. Using Allen wrench, loosen set screw on coil nut, do not remove set screw.

---



30. Using a spanner tool or similar 5/16” round tool, turn coil nut up to lower the body or turn down to raise the body. At this point additional lift will be roughly 1 to 1 on your previous assessment of lift. Moving coil nut 1” will roughly raise or lower the body the same distance. Most setups will have the coil nut threaded down between roughly 1-2 inches.

31. Tighten coil nut set screw.

---





32. Carefully lift vehicle, remove jack stands lower vehicle down to the ground.

33. Reassess lift need and adjust accordingly using same steps as previous.

---



---

#### After Install:

- Tighten all bolts securing purchased parts to specified locations.
- After completing installation using provided instructions, go through all steps again to make sure nothing was missed, not tightened or improperly assembled.
- Some components may need to be purchased separately.
- Check turn signals, headlights, fog lights (if applicable), taillights, blinkers and windshield wipers.
- Adjust mirrors, speedometer and headlights if needed.
- Make sure all gauges are fully operational.
- Drive the vehicle slowly for a couple minutes, looking and listening for abnormal noises while driving. After modification of a vehicle there will be differences in driving experiences and capabilities, be mindful of that.
- Inspect and Retorque all Bolts after 500 miles of completed installation and regularly thereafter.
- Some modification may be required.



### **Set-Up and General Coilover Notes:**

Please read **before and after** installation: Included are things you should know before and after installation of coilovers and some final setup tips to maximize the performance advantages of coilovers.

Coilovers can tend to make some sliding sounds while driving. We are stepping into race car parts and some level of sound is to be expected.

Once final adjustments have been made on spring compression and the vehicle is at a lift/ride height that you are satisfied with. Rotate the top and bottom springs so that that each end of the top and bottom coil that rest on the coil slider are 180 degrees opposite each other. This will help balance the coil slider evenly and alleviate some of the associate noises. If this is unsatisfactory for your needs, there are aftermarket spring sliders that can be purchased additionally that will help alleviate this noise. Please give us a call for information on this accessory product.

Spring compression applied with the coil nut on top of the springs will VARY between all vehicles and may be different at all 4 corners. This is due to added and or removed weight to the vehicle. The fact that all 4 corners have different weights from the factory, added accessories and or removing factory components all play a part in the vehicles corner weight and are always varying. Do not be afraid to adjust each coilover spring nut differently on each corner.

We recommend if 3" or more spring compression/preload is needed to achieve your desired lift height, our HD Coilover Spring set should be used, they are sold separately, contact EVO MFG for more information. Lastly the passenger side is heavier and will require slightly more spring compression.

Achievable lift height will vary between each vehicle due to the added and/or reduced weight of the vehicle. Additionally, actual lift is subjective. All Jeeps come from the factory with different heights based on accessories and spring packages etc. General lift increases are made by an average and/or an understanding of what a 3" or 4" lift etc. should be. Therefore in order to achieve the desired height you are looking for, spring changes may be needed and are sold separate to our standard kit.

We have done extensive testing on these kits with many variables and know we have an excellent spring package straight out of the box, but your vehicle and/or needs may vary and therefore a spring change may be needed to accomplish your desired setup.





Once the desired right height is achieved, lower the 2 secondary coil rings (2 silver rings inside the top coil spring) so that there is a  $\frac{1}{2}$ " gap between the bottom of the secondary rings and coil slider. The 2 secondary coil rings can be moved by a tap with a flat head screw driver against the machined groove to break the 2 loose from each other. Once loose, thread them down paying attention that there is a rubber O-ring between that will need to be pushed/rolled down as well. Set the lower ring at about  $\frac{1}{2}$ "-1" distance from the coil slider, tighten the 2 secondary rings towards each other with flathead screw driver and tap of a hammer. This  $\frac{1}{2}$ "-1" is a rough dimension and can be adjusted to your liking and additional payload carrying requirements.





Recommended Torque:

Size	Grade 2		Grade 5		Grade 8		18-8 S/S	
	Coarse	Fine	Coarse	Fine	Coarse	Fine	Coarse	Fine
<b>#4*</b>	-	-	-	-	-	-	5.2	-
<b>#6*</b>	-	-	-	-	-	-	9.6	-
<b>#8*</b>	-	-	-	-	-	-	19.8	-
<b>#10*</b>	-	-	-	-	-	-	22.8	31.7
<b>1/4</b>	4	4.7	6.3	7.3	9	10	6.3	7.8
<b>5/16</b>	8	9	13	14	18	20	11	11.8
<b>3/8</b>	15	17	23	26	33	37	20	22
<b>7/16</b>	24	27	37	41	52	58	31	33
<b>1/2</b>	37	41	57	64	80	90	43	45
<b>9/16</b>	53	59	82	91	115	129	57	63
<b>5/8</b>	73	83	112	128	159	180	93	104
<b>3/4</b>	125	138	200	223	282	315	128	124
<b>7/8</b>	129	144	322	355	454	501	194	193
<b>1+</b>	188	210	483	541	682	764	287	289



EVO Manufacturing

Jeep Wrangler JL/JLU

JL/JLU Rear Bolt-On Coilover Kit

EVO- 3029B





Before starting installation procedure please read <http://evomfg.com>Returns-Warranties-Shipping>

**CAREFULLY READ AND FOLLOW ALL INSTRUCTIONS IN THIS MANUAL AND KEEP FOR FUTURE REFERENCE. IF YOU HAVE ANY QUESTIONS ABOUT THE PRODUCT CALL EVO MANUFACTURING. FAILURE TO FOLLOW GUIDELINES COULD RESULT IN MALFUNCTION OF PARTS OR INJURY. PLEASE HAVE A TRAINED PROFESSIONAL ASSIST WITH OR INSTALL ALL PRODUCTS. INSTALLING EVO MFG PRODUCTS OR KITS DEMANDS SPECIFIC KNOWLEDGE, TOOLS AND EXPERIENCE. GENERAL KNOWLEDGE OF HOW TO USE LATER SPECIFIED TOOLS AND/OR LIMITED EXPERIENCE WITH EVO MFG PRODUCTS MAY NOT BE ENOUGH TO PROPERLY COMPLETE THESE TASKS. SOME OF EVO MFG PRODUCTS MAY REQUIRE TWO OR MORE PEOPLE TO INSTALL SAFELY AND CORRECTLY. DO NOT ATTEMPT ALONE, ALWAYS ENLIST THE HELP OF TRAINED PROFESSIONAL WHEN NEEDED.**

**Notes: Set Up Before installation**

**This kit requires drilling and cutting of both metal and plastic.**

**Wheel backspacing adjustments may be required.**

**Cutting and Grinding required.**

**EVO MFG recommends this installation be performed by a trained professional.**

**Always use approved safety gear/glasses and weight approved jack/jack stands.**

**Keep all mounting bolts loose (installed but not torqued) we will torque later at the end of complete installation**

**READ BEFORE INSTALL:**

Re-torque all bolts after first 100 miles

High Clearance Fenders recommended

Re-torque all bolts every 3000 miles and after every off-road use

It is generally a good idea to apply Loctite to all threaded bolts.

ALWAYS wear safety glasses and other approved safety gear when working on a vehicle.

All supplied bolts torqued according to chart at end of instruction.

It is recommended all installation be performed by a trained professional. Some modification may have to be done.

Paint all unfinished surfaces after install is complete.



Parts included: Table below shows JL/JLU Rear Bolt On Coilover Kit.

Description	#	Part #	Quantity
Rear Coilover Upper Mount Driver	1	EVO-12338B	1
Rear Coilover Upper Mount Passenger	2	EVO-12339B	1
Rear Swaybar Link	3	EVO-12027RB	2
Rear 3" Bumpstops	4	EVO-10081B	2
Reservoir Mount	5	EVO-12022CZ	2
Rear Coilover Hardware	6	EVO-770081	1
Swaybar Relocation Brackets	7	EVO-12343B	2
Brake Line Bracket	8	EVO-12361CZ	2
Bushing	9	EVO-600077	2
Swaybar Bushing Tube	10	EVO-20032	4
King Shocks	11	EVO-600126K	2
Raised Trackbar Bracket	12	EVO-12328B	1
Trackbar Hardware	13	EVO-770078	1
Crush Tube/Shock Extension	14	EVO-20038	1
Rear Shock Mount Skid Driver	15	EVO-12331B	1
Rear Shock Mount Skid Passenger	16	EVO-12332B	1





#### **Recommended Tools:**

- Allen set
  - Impact with standard sockets
  - Sawzall/Cut off wheel or similar
  - Drill
- 



#### **Safety Steps for installation**

- For installing EVO MFG products always use wheel chokes to block rear tires from rolling.
  - Always make sure you have everything necessary ready before install.
  - If you have to, carefully lift front of vehicle by front frame rails extending suspension until tires leave the ground, place frame on approved jack stands for vehicle. Verify all lines/wires are not over extended.
  - Remove tires if needed for easier install.
  - Make sure to wear safety equipment (eye protection, hand protection, foot protection etc.) at all times during installation.
  - Make sure all safety precautions have been taken.
  - Always check and replace any part of vehicle that is worn or broken before starting install.
  - Do not mix anything EVO with weaker alternatives.
  - It is generally a good idea to apply liquid threadlock to all bolts.
  - Tighten included hardware to torque specifications in bottom table unless it is otherwise specified, factory bolts should be torqued to factory Jeep specifications.
- 





## **REAR INSTALL**

After parking Jeep on a flat surface, chalk wheels and engage parking brake.

1. Carefully lift rear of vehicle with jack by frame until tires leave the ground by a few inches minimum.
  2. Carefully and securely set vehicle on weight approved jack stands. It is important that the vehicle is high enough that the tires are at least few inches from the ground as the axle will need to be lowered to remove and install parts.
  3. Remove rear wheels.
- 





4. Rubicon Models: At differential, carefully pull outward on red clip at axle disconnect until it stops. It should move out about a 1/8". Then depress clip and disconnect clip/connection.
  5. Remove breather hose from differential connection. **Vehicle wiring and hoses vary, make sure all wires, hoses, lines etc. from frame to axle are freed up giving ample length to move axle downward as needed before proceeding, verify wiring/hoses etc. do not get stretched while lowering axle during this installation.**
- 



6. Remove bolt from both driver and passenger side brake line bracket at axle on rear upper control arm bracket. Free bracket from its detent.
- 





7. Support axle with jacks and remove rear sway bar end links from vehicle. (upper stud end has hex key on end of stud to prevent movement while removing nut).
- 



8. Remove rear trackbar bolt at axle.
- 





9. Remove both driver and passenger side shocks.

10. Lower axle until springs can be removed. Remove rear springs and upper coil isolators.

---



11. Remove 2 rear bolts on both sides of frame behind factory shock tower that hold on factory rear bumper support.

---





12. At rear axle, disconnect parking brake cable from axle. With cables loose of axle, route cables below frame crossmember and reconnect to rear axle.

---



13. Install EVO rear brake line bracket to axle as shown with supplied hardware.

14. Install factory brake line to EVO Bracket as shown with factory hardware.

15. Install rear bumpstop extensions to axle pad on both sides with supplied 5/16" hardware. Bolts top down, nuts on bottom. Slant in bumpstop extension should lean top forward.

---





16. Remove rear trackbar bolt at axle. Move trackbar down under/out of factory bracket. Swing trackbar above axle bracket. Slide the EVO MFG bracket tab INTO the factory axle trackbar bracket while at same time inserting trackbar into the new higher location/pocket on the EVO Bracket. Bracket will need to slide from passenger side to driver side to insert tab into bracket.



17. Place the supplied 5/8" washers as pictured prior to installing the trackbar bolts.

18. One washer goes on the inside of the top forward most hole in between the trackbar and bracket.

19. Second washer should go on the inside of the bottom rearmost hole between the factory bracket and EVO MFG bracket.

There is a third washer in hardware bag if needed.





20. At lower original bolt mounting location, insert supplied crush sleeve into bracket and loosely install factory bolt at this location. Loosely Install supplied bolt at new trackbar location. Loosely install supplied U Bolt at axle tube.



21. On driver side of bracket with bracket loosely installed, drill 15/32" hole through factory bracket. Install supplied 7/16" hardware. Torque all bracket bolts. Do not torque trackbar bolt at this time. This should be done on the ground at ride height later.



22. At rear upper shock mount at passenger frame. Using a cutting tool (if removing) or a chisel/hammer: cut off or bend in rear section of pinch seam as shown giving clearance for bracket to pass. Use touch up paint if needed.

---



23. Insert rear coilover support tower over factory rear shock mount at frame.

24. Loosely reinstall the 2 rear bolts. Reinstall or discard bumper support bracket.

---





25. Using a long 7/16" drill bit, on front side of tower drill through frame at forward hole. Drill through both sides of frame.

26. Install supplied 7/16 x 4" bolt washer and nut completely through frame.

27. Repeat rear shock support bracket steps on opposite side

---



28. Remove the 4 bolts holding swaybar to frame.

29. Lower swaybar and insert supplied EVO Swaybar drop brackets (1/2" hole tab should point toward the front of vehicle) between frame and swaybar dropping swaybar down. Use factory hardware to hold bracket to frame and supplied 3/8" hardware to mount swaybar to EVO bracket. Do so on both driver and passenger sides.

---





30. If installing with EVO JLU High Clearance Long Arm kit **SKIP THIS STEP**. Remove lower control arm bolt from axle. Slide EVO Rear shock skid over axle bracket and loosely reinstall factory control arm bolt. Repeat on opposite side.

---



31. Install rear coilovers using factory hardware on both top and bottom. Reservoir hose should exit forward of the shocks. Coilovers are side specific. The larger top shock spacer should be mounted on the frame/inside of the shock with reservoir exiting the shock towards the front of the vehicle

32. Install lower shock into axle mount/EVO Shock skid with factory bolts.

---







33. Assemble supplied swaybar end links using a light oil (WD40 or similar). Press bushing into link. Then press inner sleeve into bushings.
  34. Install swaybar links on outside of swaybar and inside of axle tab (if EVO Long Arm, mount lower swaybar link on tire side of tab) using both factory bolts and supplied M12 hardware. Upper bolt should be installed from the tire side towards frame (nut on inside of swaybar).
- 



35. Using supplied reservoir mounts (L shaped brackets), remove plastic wheel well clips forward of shock on bottom sides revealing 2 holes which are visible in the body wheel well sheet metal.
  36. Install supplied reservoir mounts to body with supplied 1/4" hardware facing down.
  37. Lift reservoir to mounting brackets. Using supplied hose clamps insert clamp through slot then around reservoir and tighten clamp. Make sure reservoir is mounted on top side of L bracket.
- 





38. Reconnect all disconnected wiring and breather hoses. Verify adequate length of all wiring/hoses at full drop of suspension and adjuster as needed.

39. Once vehicle is on ground under its own weight. Access lift requirement/adjustment needed ("I would like it 1" higher/lower"). If changes in lift need to be made. Carefully lift vehicle up by front frame until tires leave the ground, extending suspension fully and carefully set on jack stands. Using Allen wrench, loosen set screw on coil nut, do not remove set screw.

---





40. Using a spanner tool or other, turn coil up to lower the body or turn down to raise the body. At this point additional lift will be roughly 1 to 1 on your previous assessment of lift. Moving coil nut 1" will roughly raise or lower the body the same distance. Most setups will have the coil nut threaded down between roughly 1-2 inches.
  41. Tighten coil nut set screw.
  42. Carefully lift vehicle, remove jack stands lower vehicle down to the ground.
  43. Reassess lift need and adjust accordingly using same steps as previous.
- 



Once vehicle is on the ground, if you have the EVO MFG upper control arms then adjust them out until pinion is facing the transfer case. The angle of your driveshaft and angle of your pinion should have zero degrees difference between the two. **The driveshaft face and pinion face should be parallel with each other.**

---





## **Set-Up and General Coilover Notes:**

Please read **before and after** installation: Included are things you should know before and after installation of coilovers and some final setup tips to maximize the performance advantages of coilovers.

Coilovers can tend to make some sliding sounds while driving. We are stepping into race car parts and some level of sound is to be expected.

Once final adjustments have been made on spring compression and the vehicle is at a lift/ride height that you are satisfied with. Rotate the top and bottom springs so that that each end of the top and bottom coil that rest on the coil slider are 180 degrees opposite each other. This will help balance the coil slider evenly and alleviate some of the associate noises. If this is unsatisfactory for your needs, there are aftermarket spring sliders that can be purchased additionally that will help alleviate this noise. Please give us a call for information on this accessory product.

Spring compression applied with the coil nut on top of the springs will VARY between all vehicles and may be different at all 4 corners. This is due to added and or removed weight to the vehicle. The fact that all 4 corners have different weights from the factory, added accessories and or removing factory components all play a part in the vehicles corner weight and are always varying. Do not be afraid to adjust each coilover spring nut differently on each corner.

We recommend if 3" or more spring compression/preload is needed to achieve your desired lift height, our HD Coilover Spring set should be used, they are sold separately, contact EVO MFG for more information. Lastly the passenger side is heavier and will require slightly more spring compression.

Achievable lift height will vary between each vehicle due to the added and/or reduced weight of the vehicle. Additionally, actual lift is subjective. All Jeeps come from the factory with different heights based on accessories and spring packages etc. General lift increases are made by an average and/or an understanding of what a 3" or 4" lift etc. should be. Therefore in order to achieve the desired height you are looking for, spring changes may be needed and are sold separate to our standard kit.

We have done extensive testing on these kits with many variables and know we have an excellent spring package straight out of the box, but your vehicle and/or needs may vary and therefore a spring change may be needed to accomplish your desired setup.



Once the desired right height is achieved, lower the 2 secondary coil rings (2 silver rings inside the top coil spring) so that there is a ½" gap between the bottom of the secondary rings and coil slider. The 2 secondary coil rings can be moved by a tap with a flat head screw driver against the machined groove to break the 2 loose from each other. Once loose, thread them down paying attention that there is a rubber O-ring between that will need to be pushed/rolled down as well. Set the lower ring at about 1/2"-1" distance from the coil slider, tighten the 2 secondary rings towards each other with flathead screw driver and tap of a hammer. This ½"-1" is a rough dimension and can be adjusted to your liking and additional payload carrying requirements.





After Install:

- Tighten all bolts securing purchased parts to specified locations.
- After completing installation using provided instructions, go through all steps again to make sure nothing was missed, not tightened or improperly assembled.
- Some components may need to be purchased separately.
- Check turn signals, headlights, fog lights (if applicable), taillights, blinkers and windshield wipers.
- Adjust mirrors, speedometer and headlights if needed.
- Make sure all gauges are fully operational.
- Drive the vehicle slowly for a couple minutes, looking and listening for abnormal noises while driving. After modification of a vehicle there will be differences in driving experiences and capabilities, be mindful of that.
- Inspect and Retorque all Bolts after 500 miles of completed installation and regularly thereafter.
- Some modification may be required.

Recommended Torque:

Size	Grade 2		Grade 5		Grade 8		18-8 S/S	
	Coarse	Fine	Coarse	Fine	Coarse	Fine	Coarse	Fine
<b>#4*</b>	-	-	-	-	-	-	5.2	-
<b>#6*</b>	-	-	-	-	-	-	9.6	-
<b>#8*</b>	-	-	-	-	-	-	19.8	-
<b>#10*</b>	-	-	-	-	-	-	22.8	31.7
<b>1/4</b>	4	4.7	6.3	7.3	9	10	6.3	7.8
<b>5/16</b>	8	9	13	14	18	20	11	11.8
<b>3/8</b>	15	17	23	26	33	37	20	22
<b>7/16</b>	24	27	37	41	52	58	31	33
<b>1/2</b>	37	41	57	64	80	90	43	45
<b>9/16</b>	53	59	82	91	115	129	57	63
<b>5/8</b>	73	83	112	128	159	180	93	104
<b>3/4</b>	125	138	200	223	282	315	128	124
<b>7/8</b>	129	144	322	355	454	501	194	193
<b>1+</b>	188	210	483	541	682	764	287	289



EVO Manufacturing

EVO-3030F/R JL Front and Rear Limit Strap Instructions



This limit strap kit is intended to be used with the EVO MFG Enforcer PRO suspension systems.

Installation is recommended by a trained professional.

Always wear approved safety gear while performing all installations.

1. Safely park vehicle on flat level surface. Set parking brake
2. Chalk tires

### FRONT INSTALLATION

3. Using supplied limit strap (shorter length is used in the front), nut tab and 7/16" bolt and washer. While holding nut tab by bent end, insert nut tab through larger top hole in frame so nut end is concentric with frame hole below. Insert 7/16" bolt with washer through end loop of limit strap and thread through frame hole into tab nut.





4. On axle side. Using supplied ½" bolt, washer and nut install lower end of limit strap loop to the inner factory JL shock mount tab.



5. Repeat on opposite side.

## REAR INSTALLATION

6. With rear swaybar bracket installed (supplied with EVO MFG Rear JL Coilover kit). Using supplied  $\frac{1}{2}$ " bolt, washers and nut, install bolt through limit strap loop and secure to tab on the front of the rear swaybar bracket.



7. On rear axle. Drill/enlarge existing hole in rear lower control arm brackets to  $\frac{1}{2}$ ". Using supplied  $\frac{1}{2}$ " bolt, washers, nut, install lower rear limit strap loop end to drilled hole in axle bracket. Use additional washer between axle bracket and limit strap loop to space limit strap off bracket. Nut can be accessed from underside of bracket by tapping nut to wrench end and inserting upwards.



- Repeat on opposite side. On driverside at frame bracket, use supplied spacer tube to space limit strap towards tire side of vehicle as shown with longer supplied  $\frac{1}{2}$ " bolt.



Size	Recommended Torque											
	Grade 2		Grade 5		Grade 8		18-8 S/S		Bronze		Brass	
	Coarse	Fine	Coarse	Fine	Coarse	Fine	Coarse	Fine	Coarse	Fine	Coarse	Fine
<b>#4*</b>	-	-	-	-	-	-	5.2	-	4.8	-	4.3	-
<b>#6*</b>	-	-	-	-	-	-	9.6	-	8.9	-	7.9	-
<b>#8*</b>	-	-	-	-	-	-	19.8	-	18.4	-	16.2	-
<b>#10*</b>	-	-	-	-	-	-	22.8	31.7	21.2	29.3	18.6	25.9
<b>1/4</b>	4	4.7	6.3	7.3	9	10	6.3	7.8	5.7	7.3	5.1	6.4
<b>5/16</b>	8	9	13	14	18	20	11	11.8	10.3	10.9	8.9	9.7
<b>3/8</b>	15	17	23	26	33	37	20	22	18	20	16	18
<b>7/16</b>	24	27	37	41	52	58	31	33	29	31	26	27
<b>1/2</b>	37	41	57	64	80	90	43	45	40	42	35	37
<b>9/16</b>	53	59	82	91	115	129	57	63	53	58	47	51
<b>5/8</b>	73	83	112	128	159	180	93	104	86	96	76	85
<b>3/4</b>	125	138	200	223	282	315	128	124	104	102	118	115
<b>7/8</b>	129	144	322	355	454	501	194	193	178	178	159	158
<b>1+</b>	188	210	483	541	682	764	287	289	265	240	235	212

Retorque all bolts after 500 miles



EVO Manufacturing

EVO-3030F/R JL Front and Rear Limit Strap Instructions



This limit strap kit is intended to be used with the EVO MFG Enforcer PRO suspension systems.

Installation is recommended by a trained professional.

Always wear approved safety gear while performing all installations.

1. Safely park vehicle on flat level surface. Set parking brake
2. Chalk tires

### FRONT INSTALLATION

3. Using supplied limit strap (shorter length is used in the front), nut tab and 7/16" bolt and washer. While holding nut tab by bent end, insert nut tab through larger top hole in frame so nut end is concentric with frame hole below. Insert 7/16" bolt with washer through end loop of limit strap and thread through frame hole into tab nut.



4. On axle side. Using supplied ½" bolt, washer and nut install lower end of limit strap loop to the inner factory JL shock mount tab.



5. Repeat on opposite side.



## REAR INSTALLATION

6. With rear swaybar bracket installed (supplied with EVO MFG Rear JL Coilover kit). Using supplied  $\frac{1}{2}$ " bolt, washers and nut, install bolt through limit strap loop and secure to tab on the front of the rear swaybar bracket.



7. On rear axle. Drill/enlarge existing hole in rear lower control arm brackets to  $\frac{1}{2}$ ". Using supplied  $\frac{1}{2}$ " bolt, washers, nut, install lower rear limit strap loop end to drilled hole in axle bracket. Use additional washer between axle bracket and limit strap loop to space limit strap off bracket. Nut can be accessed from underside of bracket by tapping nut to wrench end and inserting upwards.



- Repeat on opposite side. On driverside at frame bracket, use supplied spacer tube to space limit strap towards tire side of vehicle as shown with longer supplied  $\frac{1}{2}$ " bolt.



Size	Recommended Torque											
	Grade 2		Grade 5		Grade 8		18-8 S/S		Bronze		Brass	
	Coarse	Fine	Coarse	Fine	Coarse	Fine	Coarse	Fine	Coarse	Fine	Coarse	Fine
<b>#4*</b>	-	-	-	-	-	-	5.2	-	4.8	-	4.3	-
<b>#6*</b>	-	-	-	-	-	-	9.6	-	8.9	-	7.9	-
<b>#8*</b>	-	-	-	-	-	-	19.8	-	18.4	-	16.2	-
<b>#10*</b>	-	-	-	-	-	-	22.8	31.7	21.2	29.3	18.6	25.9
<b>1/4</b>	4	4.7	6.3	7.3	9	10	6.3	7.8	5.7	7.3	5.1	6.4
<b>5/16</b>	8	9	13	14	18	20	11	11.8	10.3	10.9	8.9	9.7
<b>3/8</b>	15	17	23	26	33	37	20	22	18	20	16	18
<b>7/16</b>	24	27	37	41	52	58	31	33	29	31	26	27
<b>1/2</b>	37	41	57	64	80	90	43	45	40	42	35	37
<b>9/16</b>	53	59	82	91	115	129	57	63	53	58	47	51
<b>5/8</b>	73	83	112	128	159	180	93	104	86	96	76	85
<b>3/4</b>	125	138	200	223	282	315	128	124	104	102	118	115
<b>7/8</b>	129	144	322	355	454	501	194	193	178	178	159	158
<b>1+</b>	188	210	483	541	682	764	287	289	265	240	235	212

Retorque all bolts after 500 miles



EVO Manufacturing

EVO-3030F/R JL Front and Rear Limit Strap Instructions



This limit strap kit is intended to be used with the EVO MFG Enforcer PRO suspension systems.

Installation is recommended by a trained professional.

Always wear approved safety gear while performing all installations.

1. Safely park vehicle on flat level surface. Set parking brake
2. Chalk tires

### FRONT INSTALLATION

3. Using supplied limit strap (shorter length is used in the front), nut tab and 7/16" bolt and washer. While holding nut tab by bent end, insert nut tab through larger top hole in frame so nut end is concentric with frame hole below. Insert 7/16" bolt with washer through end loop of limit strap and thread through frame hole into tab nut.



4. On axle side. Using supplied ½" bolt, washer and nut install lower end of limit strap loop to the inner factory JL shock mount tab.



5. Repeat on opposite side.

## REAR INSTALLATION

6. With rear swaybar bracket installed (supplied with EVO MFG Rear JL Coilover kit). Using supplied  $\frac{1}{2}$ " bolt, washers and nut, install bolt through limit strap loop and secure to tab on the front of the rear swaybar bracket.





7. On rear axle. Drill/enlarge existing hole in rear lower control arm brackets to  $\frac{1}{2}$ ". Using supplied  $\frac{1}{2}$ " bolt, washers, nut, install lower rear limit strap loop end to drilled hole in axle bracket. Use additional washer between axle bracket and limit strap loop to space limit strap off bracket. Nut can be accessed from underside of bracket by tapping nut to wrench end and inserting upwards.



- Repeat on opposite side. On driverside at frame bracket, use supplied spacer tube to space limit strap towards tire side of vehicle as shown with longer supplied  $\frac{1}{2}$ " bolt.



Size	Recommended Torque											
	Grade 2		Grade 5		Grade 8		18-8 S/S		Bronze		Brass	
	Coarse	Fine	Coarse	Fine	Coarse	Fine	Coarse	Fine	Coarse	Fine	Coarse	Fine
<b>#4*</b>	-	-	-	-	-	-	5.2	-	4.8	-	4.3	-
<b>#6*</b>	-	-	-	-	-	-	9.6	-	8.9	-	7.9	-
<b>#8*</b>	-	-	-	-	-	-	19.8	-	18.4	-	16.2	-
<b>#10*</b>	-	-	-	-	-	-	22.8	31.7	21.2	29.3	18.6	25.9
<b>1/4</b>	4	4.7	6.3	7.3	9	10	6.3	7.8	5.7	7.3	5.1	6.4
<b>5/16</b>	8	9	13	14	18	20	11	11.8	10.3	10.9	8.9	9.7
<b>3/8</b>	15	17	23	26	33	37	20	22	18	20	16	18
<b>7/16</b>	24	27	37	41	52	58	31	33	29	31	26	27
<b>1/2</b>	37	41	57	64	80	90	43	45	40	42	35	37
<b>9/16</b>	53	59	82	91	115	129	57	63	53	58	47	51
<b>5/8</b>	73	83	112	128	159	180	93	104	86	96	76	85
<b>3/4</b>	125	138	200	223	282	315	128	124	104	102	118	115
<b>7/8</b>	129	144	322	355	454	501	194	193	178	178	159	158
<b>1+</b>	188	210	483	541	682	764	287	289	265	240	235	212

Retorque all bolts after 500 miles



EVO Manufacturing  
Jeep Wrangler JL/JLU  
JL/JLU Spare Tire Carrier  
EVO- 3032/3032B





Before starting installation procedure please read <http://evomfg.com>Returns-Warranties-Shipping>

**CAREFULLY READ AND FOLLOW ALL INSTRUCTIONS IN THIS MANUAL AND KEEP FOR FUTURE REFERENCE. IF YOU HAVE ANY QUESTIONS ABOUT THE PRODUCT CALL EVO MANUFACTURING. FAILURE TO FOLLOW GUIDELINES COULD RESULT IN MALFUNCTION OF PARTS OR INJURY. PLEASE HAVE A TRAINED PROFESSIONAL ASSIST WITH OR INSTALL ALL PRODUCTS. INSTALLING EVO MFG PRODUCTS OR KITS DEMANDS SPECIFIC KNOWLEDGE, TOOLS AND EXPERIENCE. GENERAL KNOWLEDGE OF HOW TO USE LATER SPECIFIED TOOLS AND/OR LIMITED EXPERIENCE WITH EVO MFG PRODUCTS MAY NOT BE ENOUGH TO PROPERLY COMPLETE THESE TASKS. SOME OF EVO MFG PRODUCTS MAY REQUIRE TWO OR MORE PEOPLE TO INSTALL SAFELY AND CORRECTLY. DO NOT ATTEMPT ALONE, ALWAYS ENLIST THE HELP OF TRAINED PROFESSIONAL WHEN NEEDED.**

**Notes: Set Up Before installation**

**Carefully remove factory spare tire, use proper precaution**

**Unless otherwise specified, keep all mounting bolts loose (installed but not torqued) we will torque later at the end of complete installation**

**READ BEFORE INSTALL:**

**READ BEFORE INSTALLATION:**

- \*Some backspacing wheels/tire width combinations (small backspacing/wide tires) may require a single wheel spacer to properly mount to tire carrier. While this tire carrier will mount/clear a larger tire, we currently are recommending max 37".
- \*Powder coated tire carriers are coated exterior only, additional coating/paint should be checked and sprayed by installer before install.
- \*You will need a Torx bit set ranging from T6– T55 to complete installation.
- \*It is recommended to NOT open tailgate until installation is complete. Some preload adjustments may need to be made after complete installation. Do so as needed.
- \*It is generally a good idea to apply Loctite to all threaded bolts.
- \*ALWAYS wear safety glasses and other approved safety gear when working on a vehicle.
- \*All supplied bolts torqued according to chart at end of instruction.
- \*It is recommended all installation be performed by a trained professional. Some modification may have to be done.
- \*Paint all unfinished surfaces after install is complete.



Parts included: Table below shows black (painted) JL Spare Tire Carrier.

Description	#	Part #	Quantity
Tire Carrier	1	EVO-12344/B	1
Front Wheel Mount	2	EVO-12345/B	1
Rear Wheel Mount	3	EVO-12346/B	1
Hinge	4	EVO-12347	2
Hinge Pad	5	EVO-760057	2
Spacer Plate	6	EVO-12348	2
Hinge Tube	7	EVO-12167	2
Sleeve Bearing	8	EVO-900390	4
Shims	9	EVO-12376	2
Hardware Bag	10	EVO-770082	1

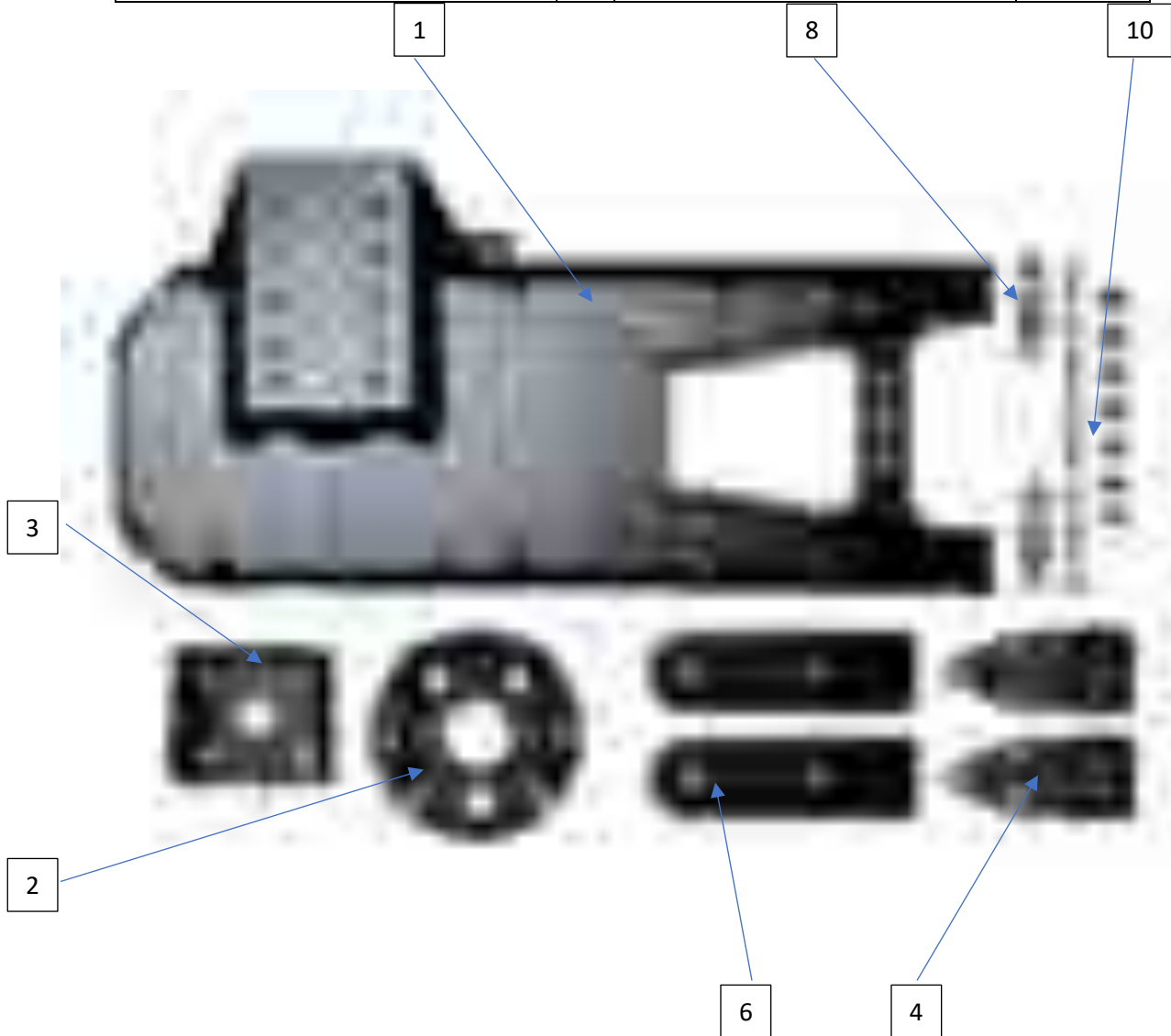



#### **Recommended Tools:**

- Allen set
  - Impact with standard sockets
  - Standard/Metric Sockets
  - T5-T55 Torx bit
- 



#### **Safety Steps for installation**

- For installing EVO MFG products always use wheel chokes to block rear tires from rolling.
  - Always make sure you have everything necessary ready before install.
  - If you have to, carefully lift front of vehicle by front frame rails extending suspension until tires leave the ground, place frame on approved jack stands for vehicle. Verify all lines/wires are not over extended.
  - Remove tires if needed for easier install.
  - Make sure to wear safety equipment (eye protection, hand protection, foot protection etc.) at all times during installation.
  - Make sure all safety precautions have been taken.
  - Always check and replace any part of vehicle that is worn or broken before starting install.
  - Do not mix anything EVO with weaker alternatives.
  - It is generally a good idea to apply liquid threadlock to all bolts.
  - Tighten included hardware to torque specifications in bottom table unless it is otherwise specified, factory bolts should be torqued to factory Jeep specifications.
- 





## **INSTALL**

Park vehicle on flat ground, put in park and apply emergency brake.

1. Check that the barrels on tire carrier are clean and free of coating. Light sanding inside may be required.
2. Install the 4 hinge bushings and 2 inner sleeves into both hinge barrels. Use a light oil (WD-40) inside the barrel, apply small amount of grease on to inside diameter of hinge bushing, these should have a snug fit. A light tap with a rubber mallet may be required to seat the bushings, but do not force them. Hand install at first and only tap to seat them.







3. Using 4 supplied 7/16 bolts, 4 lock nuts, and 8 washers (11/16 wrench and socket), secure the bolt plate to the tire carrier.
  4. There are three wheel mount location options, your combination of tire size and bumper may vary. Highest location is recommended for clearance and large tire sizes. Two lower locations may be an option for your specific setup and could possibly increase rear window visibility.
  5. You will need to access the inside of the Tailgate Tire Carrier to reach the nuts so be sure to do this before bolting it to the tailgate.
- 



6. Install rubber bumpers to hinge assemblies using the supplied button head bolts and washer.
- 





7. Safely remove tire from factory rear tire mount, two people may ease removal.
  8. Using T25 Torx bit, remove 2 small screws on left and right side of wheel studs holding wheel stud plate to tire mount.
- 



9. Using a flat head screwdriver or something similar, press just on the outside of each of the wheel studs (ring between wheel stud and wheel mount on each of the 3 studs) until the wheel stud plate/camera mount free itself from the wheel mount.

This will take some pressure so support wheel mount.





10. Remove rear camera cover if applicable with T40 Torx bit from underside of cover turning clockwise to the unlocked symbol. Pull outward to remove.

11. Remove 8 13mm hex bolts (2 at each corner) holding the factory tire mount to tailgate.

---



12. Using T25 Torx bit, remove 7 screws holding 3rd brake light assembly halves together.

13. Carefully pry the third brake light assembly apart revealing light mount.

14. Remove 2 screws (keep screws) holding light to mount.

15. Disconnect wiring from retainers. This should allow the wheel mount to separate from vehicle.

---





16. Open tailgate. On passenger side. Remove 3 bolts/floor hooks from floor. Remove floor panel and set aside.
- 



17. Remove single screw in rear trunk panel on side of vehicle just rearward of rear passenger door jam.
- 





18. At rear roll bar where seat belt enters plastic side panel lift up on square plastic cover to unclip from main cover.

---



19. With a sharp and firm pull, pull main panel away from side of vehicle.

This panel is held to body with retaining clips internally. It will need to be pulled to disconnect these clips. Gently and strategically pull down the line until panel is free from body. Pay attention to clips as this will need to be reversed at end of installation.

If equipped with subwoofer reach behind and disconnect wiring. Set panel aside.

---





20. At the rear there are 2 square stickers covering the access to the tailgate hinges. Carefully remove these stickers, they can be reused or replaced after install. Place in safe place sticker side up.

---



21. With tailgate closed and rear window open, using a Torx Bit (T55) remove the 2 bolts holding the hinges to tailgate, both top and bottom. From here out it is recommended to not open the tailgate until complete.

---





22. While tailgate is still closed and rear window open. Reach inside using a socket on extension, remove the 3 bolts both top and bottom through the square access holes removing the hinges from the vehicle. Retain 6 bolts to attached EVO Hinges later in instruction.
- 



23. Loosely install hinge brackets to assembled tire carrier, top and bottom pivots, using supplied 9/16 bolts washers and nuts. Insert bolts from the top down

24. With hinges loosely installed to tire carrier pivots, insert hinge bracket bolt flanges into JL body holes. Loosely install the factory 3 bolts securing the hinges top and bottom to vehicle.
- 





25. Lower hinge bracket may require 0-2 shim plates on body side of mounting, depending on additional tire weight. We have found generally 33-35s are best with 1 shim plate and 36-37 are best with 2, but your setup weight may require different, start with above and adjust if needed. These should be installed on the lower hinge bracket only between EVO Bracket and the body.

---



26. Swing tire carrier towards tailgate and route wire for camera and brake light (if applicable as shown through carrier holes) out of camera tube.

Camera wire should be run through end of camera tube. Brake light wire should be run through camera tube and out the bottom.

---







27. Using the supplied M10 bolts, insert into 4 right side bolt holes (2 on top leg and 2 on bottom leg of tire carrier). With bolts protruding from the mounting face of the tire carrier slide on spacer plates to bolt top and bottom bolts.
- 



28. Carefully swing tire carrier towards tailgate and align 4 bolts with tailgate right side hinge bolt holes. Loosely thread all 4 bolts into tailgate.
29. Loosely install the 8 factory 13mm Hex bolts through tire carrier into original wheel mounting holes on tailgate.
30. With all tire carrier mounting bolts loosely installed. Using a flat head screw driver or small pry bar etc (apply protective tape on end to prevent scratching). Lift up on tailgate until the body lines are acceptable to you.
31. While tailgate is lifted in alignment, tighten all bolts into tailgate and 6 inside hinge bracket bolts to factory specifications. Then tighten the large 9/16" pivot bolts to 129 ft/lbs.
- 





32. Install wheel stud plate/camera into EVO wheel mount as shown using 2 factory bolts at counterbore locations.

33. Place the wheel mount over the EVO tire carrier bracket

---



34. Loosely install the supplied 7/16 bolts, washer nuts into the 3 slotted holes.

---





35. Install your wheel and tire and fully tighten the lug nuts to the wheel mount. With the tire secured, slide the wheel assembly toward the tailgate until the tire contacts the tire carrier on passenger side. On the slider/EVO Wheel mount, mark the plate where it stops (this is easier to mark with the tailgate open). Note: If your wheel/tire combo is beyond the reach of the support mount, you will need to use a wheel spacer.
36. Once slider is marked, remove the wheel and tire.
37. Move the slider back (toward the tailgate) to cover the mark you made in previous step (you should move it back around 3/16" inward covering your mark). Fully tighten the 3 bolts on the slider so that it can no longer move. This will make sure the tire is tightly compressed against the tire carrier.



**These previous tire/wheel step are very important. Do not overlook. The tire must be firmly mounted into the tire carrier face to prevent rattles, noise and fatigue of components.**

- 
38. Reinstall wheel to mounting studs.



39. Open/close tailgate and check proper alignment at door catch. Some adjustments to hinge and or door latch may need to be made at this time to allow for smooth operation. Do so at this time.
  40. Reversing previous steps, Reapply or replace rear access stickers to inside body panel.
  41. Reinstall inner plastic interior side panel to vehicle using factory clips. (reconnect subwoofer wiring if applicable). Align and press in until panel clip reattached.
  42. Reinstall removed rear panel screw just rearward of passenger side rear door jam.
  43. Reinstall seat belt panel cover
  44. Reinstall rear floor panel, 3 floor hooks/bolts.
- 





45. If equipped with rear camera. Route wiring  
as shown.

---



46. Install camera and supplied EVO brake light  
bracket to factory brake light.

47. Install Camera with brakelight bracket on top  
using supplied small stainless steel screws to  
camera tube.

---





Slight lowering of the tailgate after installing heavy tire and wheel may occur. Adjusting tire preload to ease closure if needed can be done by loosening the 9/16" pivot bolts. Lifting tailgate until resistance is felt and torquing bolts while lift up.

Check/retorque all bolts after 500 miles

After Install:

- Tighten all bolts securing purchased parts to specified locations.
- After completing installation using provided instructions, go through all steps again to make sure nothing was missed, not tightened or improperly assembled.
- Some components may need to be purchased separately.
- Check turn signals, headlights, fog lights (if applicable), taillights, blinkers and windshield wipers.
- Adjust mirrors, speedometer and headlights if needed.
- Make sure all gauges are fully operational.
- Drive the vehicle slowly for a couple minutes, looking and listening for abnormal noises while driving. After modification of a vehicle there will be differences in driving experiences and capabilities, be mindful of that.
- Inspect and Retorque all Bolts after 500 miles of completed installation and regularly thereafter.
- Some modification may be required.

Recommended Torque:

Size	Grade 2		Grade 5		Grade 8		18-8 S/S	
	Coarse	Fine	Coarse	Fine	Coarse	Fine	Coarse	Fine
#4*	-	-	-	-	-	-	5.2	-
#6*	-	-	-	-	-	-	9.6	-
#8*	-	-	-	-	-	-	19.8	-
#10*	-	-	-	-	-	-	22.8	31.7
1/4	4	4.7	6.3	7.3	9	10	6.3	7.8
5/16	8	9	13	14	18	20	11	11.8
3/8	15	17	23	26	33	37	20	22
7/16	24	27	37	41	52	58	31	33
1/2	37	41	57	64	80	90	43	45
9/16	53	59	82	91	115	129	57	63
5/8	73	83	112	128	159	180	93	104
3/4	125	138	200	223	282	315	128	124
7/8	129	144	322	355	454	501	194	193
1+	188	210	483	541	682	764	287	289



EVO Manufacturing

Jeep Wrangler JL

JLU Bomber Rockers

EVO- 3033





Before starting installation procedure please read <http://evomfg.com>Returns-Warranties-Shipping>

**CAREFULLY READ AND FOLLOW ALL INSTRUCTIONS IN THIS MANUAL AND KEEP FOR FUTURE REFERENCE. IF YOU HAVE ANY QUESTIONS ABOUT THE PRODUCT CALL EVO MANUFACTURING. FAILURE TO FOLLOW GUIDELINES COULD RESULT IN MALFUNCTION OF PARTS OR INJURY. PLEASE HAVE A TRAINED PROFESSIONAL ASSIST WITH OR INSTALL ALL PRODUCTS. INSTALLING EVO MFG PRODUCTS OR KITS DEMANDS SPECIFIC KNOWLEDGE, TOOLS AND EXPERIENCE. GENERAL KNOWLEDGE OF HOW TO USE LATER SPECIFIED TOOLS AND/OR LIMITED EXPERIENCE WITH EVO MFG PRODUCTS MAY NOT BE ENOUGH TO PROPERLY COMPLETE THESE TASKS. SOME OF EVO MFG PRODUCTS MAY REQUIRE TWO OR MORE PEOPLE TO INSTALL SAFELY AND CORRECTLY. DO NOT ATTEMPT ALONE, ALWAYS ENLIST THE HELP OF TRAINED PROFESSIONAL WHEN NEEDED.**

**Notes: Set Up Before installation**

**Always wear approved safety equipment while performing the installation.**

**It is recommended that EVO MFG Bombers/Skins are installed uncoated/painted first, then coat/paint and perform final assembly.**

**Keep all mounting bolts loose (installed but not torqued) we will torque later at the end of complete installation**

**READ BEFORE INSTALL:**

It is generally a good idea to apply Loctite to all threaded bolts.

ALWAYS wear safety glasses and other approved safety gear when working on a vehicle.

All supplied bolts torqued according to chart at end of instruction.

It is recommended all installation be performed by a trained professional. Some modification may have to be done.





Parts included: Table below shows JL Bomber Rocker w/ Rock Skins.

Description	#	Part #	Quantity
JL Bomber Rocker Driver	3	EVO-12351	1
JL Bomber Rocker Passenger	4	EVO-12352	1
Front/Mid Pinch Seam Mounts	5	EVO-12353	4
Rear Pinch Seam Mounts	6	EVO-12354	2
Hardware	7	EVO-770083	1
Hardware	8	EVO-770084	1
Froward Bodymount Crush Tube	9	EVO-12355	2

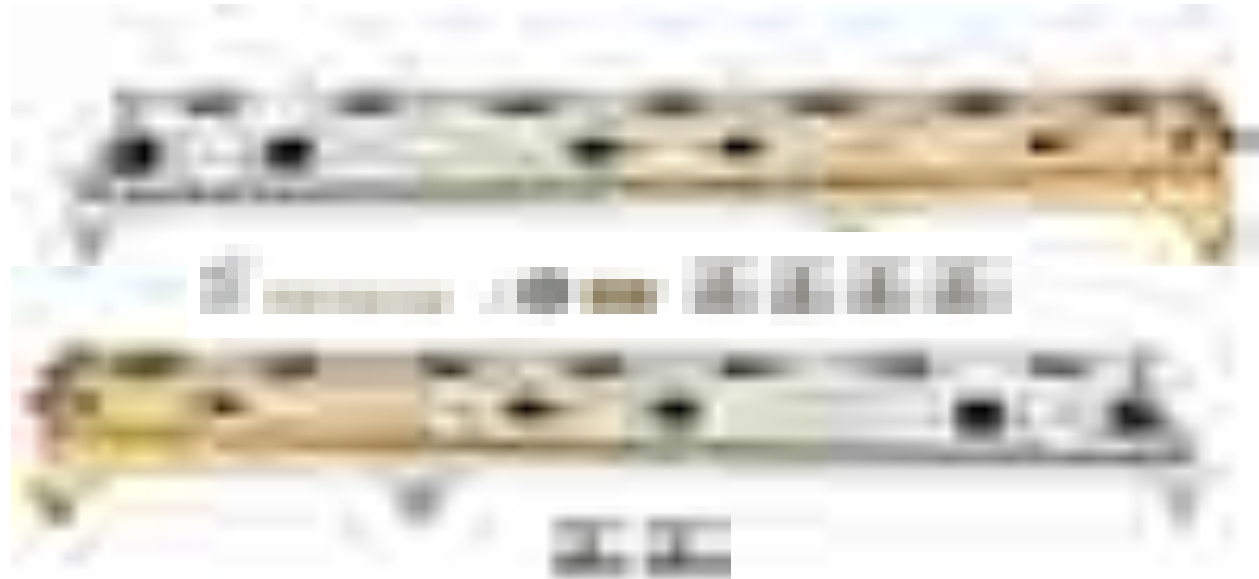



#### **Recommended Tools:**

- Allen set
  - Impact with standard sockets
- 



#### **Safety Steps for installation**

- For installing EVO MFG products always use wheel chokes to block rear tires from rolling.
  - Always make sure you have everything necessary ready before install.
  - If you have to, carefully lift front of vehicle by front frame rails extending suspension until tires leave the ground, place frame on approved jack stands for vehicle. Verify all lines/wires are not over extended.
  - Remove tires if needed for easier install.
  - Make sure to wear safety equipment (eye protection, hand protection, foot protection etc.) at all times during installation.
  - Make sure all safety precautions have been taken.
  - Always check and replace any part of vehicle that is worn or broken before starting install.
  - Do not mix anything EVO with weaker alternatives.
  - It is generally a good idea to apply liquid threadlock to all bolts.
  - Tighten included hardware to torque specifications in bottom table unless it is otherwise specified, factory bolts should be torqued to factory Jeep specifications.
- 





## **INSTALL**

Park vehicle on flat ground, turn off vehicle with parking brake engaged.

1. Uninstall front body mount bolt. Loosen (do not remove) middle and rearward body mount bolts.
- 





2. Loosely preassemble inner seam mounts to main bomber rails. The inner seam mounts with the 4-hole pattern will be used at both front and middle locations. The inner seam mount with the 2-hole pattern will be used at the rear location only. Shim plate should be installed on top side of all inner seam mounts.
- 





- Using the supplied 3/8" hardware, loosely install all 6 bolts from bottom up at all 3 inner seam mount locations (2 each mount). It is best to tighten these to the point just before getting tight (loose but almost tight). This will save time later during final install while tightening all bolts on the vehicle.

On top side of bomber, install all 3 seam mount button head bolts completely.

---



- Lift bomber rockers onto jeep (with help from another person or jack) and guide factory bolts through bomber and back into factory locations. Do not tighten.

Note: use crush sleeve on front bolt.

---





5. Insert spacer tube in gap between Bomber and front body mount.
  6. Loosely (just before tightening) install the supplied M12 bolt with washer at this front body mount location.
  7. Reinstall the middle body mount bolt, just before tight.
- 



8. Using the factory holes in body pinch seam install supplied 5/16" bolts and washers through body and into inner seam mounts.
- 

On 5/16" bolts, install bolts with washer on head side only. The inside nut is a flange nut, no washers are used on flange nut.





When all bolts in parts are installed, apply an inward pressure on bomber, tighten body mount bolts.

---



Then tighten all pinch seam bolts.

---



Lastly tighten down Rock Skin bolts.

---





After Install:

- Tighten all bolts securing purchased parts to specified locations.
- After completing installation using provided instructions, go through all steps again to make sure nothing was missed, not tightened or improperly assembled.
- Some components may need to be purchased separately.
- Check turn signals, headlights, fog lights (if applicable), taillights, blinkers and windshield wipers.
- Adjust mirrors, speedometer and headlights if needed.
- Make sure all gauges are fully operational.
- Drive the vehicle slowly for a couple minutes, looking and listening for abnormal noises while driving. After modification of a vehicle there will be differences in driving experiences and capabilities, be mindful of that.
- Inspect and Retorque all Bolts after 500 miles of completed installation and regularly thereafter.
- Some modification may be required.

Recommended Torque:

Size	Grade 2		Grade 5		Grade 8		18-8 S/S	
	Coarse	Fine	Coarse	Fine	Coarse	Fine	Coarse	Fine
<b>#4*</b>	-	-	-	-	-	-	5.2	-
<b>#6*</b>	-	-	-	-	-	-	9.6	-
<b>#8*</b>	-	-	-	-	-	-	19.8	-
<b>#10*</b>	-	-	-	-	-	-	22.8	31.7
<b>1/4</b>	4	4.7	6.3	7.3	9	10	6.3	7.8
<b>5/16</b>	8	9	13	14	18	20	11	11.8
<b>3/8</b>	15	17	23	26	33	37	20	22
<b>7/16</b>	24	27	37	41	52	58	31	33
<b>1/2</b>	37	41	57	64	80	90	43	45
<b>9/16</b>	53	59	82	91	115	129	57	63
<b>5/8</b>	73	83	112	128	159	180	93	104
<b>3/4</b>	125	138	200	223	282	315	128	124
<b>7/8</b>	129	144	322	355	454	501	194	193
<b>1+</b>	188	210	483	541	682	764	287	289





EVO Manufacturing  
EVO-3035 JLU Rocker Steps

**READ BEFORE INSTALLATION:**



1. Safely park vehicle on level ground.
2. Start by preassembling both driver and passenger side rocker steps off the vehicle. Insert step plate into main rail. From the outside in, loosely install the supplied 5 ¼" button head bolts with nuts.



3. Loosely preassemble the inner seam mount brackets to main rocker rails. The inner seam mount brackets with the **4-bolthole pattern on top** will be used at **both the front and middle locations** on each side rail. The inner seam mount with the **2-bolthole pattern on top** will be used at the **rear location only**.



- Using the supplied 3/8" hex head hardware, loosely install all 6 bolts from bottom up at all 3 inner seam mount locations (2 bolts each mount). It is best to tighten these to the point just before getting tight, loose but almost tight. This will save time later when tightening to vehicle.



- From the top down install all 10 5/16" button head screws. **Keep the 3 5/16" button head bolts at the inner seam mount brackets loose, just before tight. The other 7 can be tightened at this time.**



6. Tighten the 5 ¼" button head bolts from step 2
7. Repeat preassembly on other Rocker Step.
8. Remove factory steps/Rubicon Rails on both driver and pass side. There are 6 pinch seam nuts and 3 body bolts on each side.
9. Starting on driver side. Remove the 3 body mount bolts. Retain the middle and rear factory body mount bolts.
10. Using supplied 5/16" hex head bolts with washers. Install through inner seam mount bracket at most forward and most rearward locations (on bolt at the front of rocker step and bolt at the rear of rocker step. With 2 people, lift Bomber into location and insert front and rear bolts into existing pinch seam holes at vehicles body seam. Loosely install nut at each of these locations on top the 5/16 hex head bolts. This will loosely hold part to vehicle.



11. Using supplied 5/16" hardware, loosely install the remaining 4 5/16" hex bolts, washer and nuts at the inner seam mount bracket locations.
12. Insert the supplied crush tube at the front body mount. Between the Bomber Rocker and the body mount. Loosely (just before tightening) install the supplied M12 bolt with washer at this front body mount.
13. Reinstall the middle and rear body mount bolts, just before tight.



14. Using a jack, apply an upward and inward pressure to the Rocker Step, lifting it up to an approximate level/as installed location.
15. Tighten all 3 body mount bolts.
16. Tighten the 3 upper 5/16" button head bolts and the 6 lower 3/8" hex head bolts at the inner seam mounts.
17. Tighten the 6 5/16" hex head bolts at inner seam mount brackets at body pinch seam.
18. Repeat on opposite side.

Size	Recommended Torque											
	Grade 2		Grade 5		Grade 8		18-8 S/S		Bronze		Brass	
	Coarse	Fine	Coarse	Fine	Coarse	Fine	Coarse	Fine	Coarse	Fine	Coarse	Fine
<b>#4*</b>	-	-	-	-	-	-	5.2	-	4.8	-	4.3	-
<b>#6*</b>	-	-	-	-	-	-	9.6	-	8.9	-	7.9	-
<b>#8*</b>	-	-	-	-	-	-	19.8	-	18.4	-	16.2	-
<b>#10*</b>	-	-	-	-	-	-	22.8	31.7	21.2	29.3	18.6	25.9
<b>1/4</b>	4	4.7	6.3	7.3	9	10	6.3	7.8	5.7	7.3	5.1	6.4
<b>5/16</b>	8	9	13	14	18	20	11	11.8	10.3	10.9	8.9	9.7
<b>3/8</b>	15	17	23	26	33	37	20	22	18	20	16	18
<b>7/16</b>	24	27	37	41	52	58	31	33	29	31	26	27
<b>1/2</b>	37	41	57	64	80	90	43	45	40	42	35	37
<b>9/16</b>	53	59	82	91	115	129	57	63	53	58	47	51
<b>5/8</b>	73	83	112	128	159	180	93	104	86	96	76	85
<b>3/4</b>	125	138	200	223	282	315	128	124	104	102	118	115
<b>7/8</b>	129	144	322	355	454	501	194	193	178	178	159	158
<b>1+</b>	188	210	483	541	682	764	287	289	265	240	235	212





EVO Manufacturing

Jeep Wrangler JL

JLU Bomber Rockers

EVO- 3036





Before starting installation procedure please read <http://evomfg.com>Returns-Warranties-Shipping>

**CAREFULLY READ AND FOLLOW ALL INSTRUCTIONS IN THIS MANUAL AND KEEP FOR FUTURE REFERENCE. IF YOU HAVE ANY QUESTIONS ABOUT THE PRODUCT CALL EVO MANUFACTURING. FAILURE TO FOLLOW GUIDELINES COULD RESULT IN MALFUNCTION OF PARTS OR INJURY. PLEASE HAVE A TRAINED PROFESSIONAL ASSIST WITH OR INSTALL ALL PRODUCTS. INSTALLING EVO MFG PRODUCTS OR KITS DEMANDS SPECIFIC KNOWLEDGE, TOOLS AND EXPERIENCE. GENERAL KNOWLEDGE OF HOW TO USE LATER SPECIFIED TOOLS AND/OR LIMITED EXPERIENCE WITH EVO MFG PRODUCTS MAY NOT BE ENOUGH TO PROPERLY COMPLETE THESE TASKS. SOME OF EVO MFG PRODUCTS MAY REQUIRE TWO OR MORE PEOPLE TO INSTALL SAFELY AND CORRECTLY. DO NOT ATTEMPT ALONE, ALWAYS ENLIST THE HELP OF TRAINED PROFESSIONAL WHEN NEEDED.**

**Notes: Set Up Before installation**

**This product requires permanent drilling of holes into the body of the Jeep and installing threaded inserts. Once process has started there is no going back.**

**Rivnuts/Nutserts are used in this installation. Installation tool for this is required and not included. Thread size 1/4 -20**

**Always wear approved safety equipment while performing the installation.**

**It is recommended that EVO MFG Bombers/Skins are installed uncoated/painted first, then coat/paint and perform final assembly.**

**Keep all mounting bolts loose (installed but not torqued) we will torque later at the end of complete installation**

**READ BEFORE INSTALL:**

It is generally a good idea to apply Loctite to all threaded bolts.

ALWAYS wear safety glasses and other approved safety gear when working on a vehicle.

All supplied bolts torqued according to chart at end of instruction.

It is recommended all installation be performed by a trained professional. Some modification may have to be done.



Parts included: Table below shows JL Bomber Rocker w/ Rock Skins.

Description	#	Part #	Quantity
JL Rock Skin Driver	1	EVO-12349	1
JL Rock Skin Passenger	2	EVO-12350	1
JL Bomber Rocker Driver	3	EVO-12351	1
JL Bomber Rocker Passenger	4	EVO-12352	1
Front/Mid Pinch Seam Mounts	5	EVO-12353	4
Rear Pinch Seam Mounts	6	EVO-12354	2
Hardware	7	EVO-770083	1
Hardware	8	EVO-770084	1
Froward Bodymount Crush Tube	9	EVO-12355	2

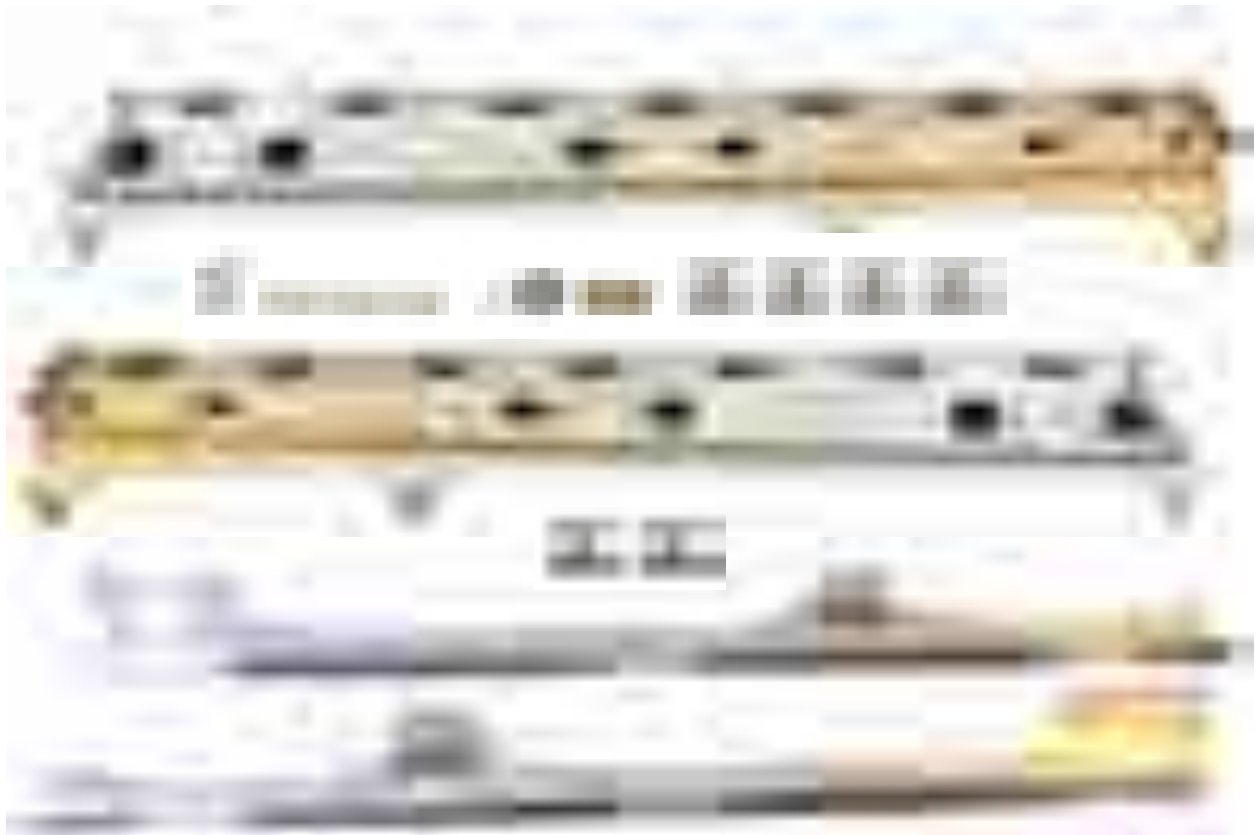



#### **Recommended Tools:**

- Allen set
  - Impact with standard sockets
  - Nutsert install tool
  - Drill and bit
- 



#### Safety Steps for installation

- For installing EVO MFG products always use wheel chokes to block rear tires from rolling.
  - Always make sure you have everything necessary ready before install.
  - If you have to, carefully lift front of vehicle by front frame rails extending suspension until tires leave the ground, place frame on approved jack stands for vehicle. Verify all lines/wires are not over extended.
  - Remove tires if needed for easier install.
  - Make sure to wear safety equipment (eye protection, hand protection, foot protection etc.) at all times during installation.
  - Make sure all safety precautions have been taken.
  - Always check and replace any part of vehicle that is worn or broken before starting install.
  - Do not mix anything EVO with weaker alternatives.
  - It is generally a good idea to apply liquid threadlock to all bolts.
  - Tighten included hardware to torque specifications in bottom table unless it is otherwise specified, factory bolts should be torqued to factory Jeep specifications.
- 





## **INSTALL**

Park vehicle on flat ground,  
parking brake engaged and  
chalk wheels.

1. Clean both sets of EVO  
MFG Rock Skins.
- 





2. Hold EVO MFG Rock Skin to vehicle and align Rock Skin using body lines/door openings. Once you find a fit that works for you, mark the 4 centermost holes between the doors.

**Before drilling it is the installers responsibility to verify fitment is acceptable. There is no turning back from here.**

3. Once the skins are in your acceptable position, using the 4 marked holes in the Rock Skin drill through the outer sheet metal of body only using a 25/64" drill bit.

Step Drill recommended

---



4. Follow manufacturers tool procedure and install nutserts into 4 drilled holes.
- 





5. Replace EVO MFG Rock Skin on the side of the vehicle and bolt to body (snug) in the 4 locations with installed nutserts. DO NOT overtighten bolts.
  6. Once Skin is bolted to body, press Skin flush to body, mark all other holes for drilling. Forward and rearward of center.
  7. Remove Skin from body. Follow tool procedure to drill holes and insert remaining nutserts.
- 



8. Loosely install Rock Skin at all bolt locations and repeat previous steps on alternate side.
- 





9. Uninstall front body mount bolt. Loosen (do not remove) middle and rearward body mount bolts.
- 



10. Loosely preassemble inner seam mounts to main bomber rails. The inner seam mounts with the 4-hole pattern will be used at both front and middle locations. The inner seam mount with the 2-hole pattern will be used at the rear location only. Shim plate should be installed on top side of all inner seam mounts.
- 







11. Using the supplied 3/8" hardware, loosely install all 6 bolts from bottom up at all 3 inner seam mount locations (2 each mount). It is best to tighten these to the point just before getting tight (loose but almost tight). This will save time later during final install while tightening all bolts on the vehicle.

On top side of bomber, install all 3 seam mount button head bolts completely.

---



12. With the help of two people, lift Bomber into location setting bomber onto Rock Skin tabs while inserting rear and middle body mount tabs into loosened body mount bolts.

13. Once bomber is placed on Rock Skins, loosely install all button head bolts in remaining Rock Skin to Bomber bolt locations.
- 





14. Insert spacer tube in gap between Bomber and front body mount.
  15. Loosely (just before tightening) install the supplied M12 bolt with washer at this front body mount location.
  16. Reinstall the middle body mount bolt, just before tight.
- 



17. Using the factory holes in body pinch seam install supplied 5/16" bolts and washers through body and into inner seam mounts.
- 

On 5/16" bolts, install bolts with washer on head side only. The inside nut is a flange nut, no washers are used on flange nut.





When all bolts in parts are installed, apply an inward pressure on bomber, tighten body mount bolts.

---



Then tighten all pinch seam bolts.

---



Lastly tighten down Rock Skin bolts.

---





After Install:

- Tighten all bolts securing purchased parts to specified locations.
- After completing installation using provided instructions, go through all steps again to make sure nothing was missed, not tightened or improperly assembled.
- Some components may need to be purchased separately.
- Check turn signals, headlights, fog lights (if applicable), taillights, blinkers and windshield wipers.
- Adjust mirrors, speedometer and headlights if needed.
- Make sure all gauges are fully operational.
- Drive the vehicle slowly for a couple minutes, looking and listening for abnormal noises while driving. After modification of a vehicle there will be differences in driving experiences and capabilities, be mindful of that.
- Inspect and Retorque all Bolts after 500 miles of completed installation and regularly thereafter.
- Some modification may be required.

Recommended Torque:

Size	Grade 2		Grade 5		Grade 8		18-8 S/S	
	Coarse	Fine	Coarse	Fine	Coarse	Fine	Coarse	Fine
<b>#4*</b>	-	-	-	-	-	-	5.2	-
<b>#6*</b>	-	-	-	-	-	-	9.6	-
<b>#8*</b>	-	-	-	-	-	-	19.8	-
<b>#10*</b>	-	-	-	-	-	-	22.8	31.7
<b>1/4</b>	4	4.7	6.3	7.3	9	10	6.3	7.8
<b>5/16</b>	8	9	13	14	18	20	11	11.8
<b>3/8</b>	15	17	23	26	33	37	20	22
<b>7/16</b>	24	27	37	41	52	58	31	33
<b>1/2</b>	37	41	57	64	80	90	43	45
<b>9/16</b>	53	59	82	91	115	129	57	63
<b>5/8</b>	73	83	112	128	159	180	93	104
<b>3/4</b>	125	138	200	223	282	315	128	124
<b>7/8</b>	129	144	322	355	454	501	194	193
<b>1+</b>	188	210	483	541	682	764	287	289



EVO Manufacturing  
Jeep Wrangler JLU 2018+  
JL Unlimited Trail Roof Rack  
EVO-3038, EVO-3038B kits





Before starting installation procedure please read <http://evomfg.com>Returns-Warranties-Shipping>

**CAREFULLY READ AND FOLLOW ALL INSTRUCTIONS IN THIS MANUAL AND KEEP FOR FUTURE REFERENCE. IF YOU HAVE ANY QUESTIONS ABOUT THE PRODUCT CALL EVO MANUFACTURING. FAILURE TO FOLLOW GUIDELINES COULD RESULT IN MALFUNCTION OF PARTS OR INJURY. PLEASE HAVE A TRAINED PROFESSIONAL ASSIST WITH OR INSTALL ALL PRODUCTS. INSTALLING EVO MFG PRODUCTS OR KITS DEMANDS SPECIFIC KNOWLEDGE, TOOLS AND EXPERIENCE. GENERAL KNOWLEDGE OF HOW TO USE LATER SPECIFIED TOOLS AND/OR LIMITED EXPERIENCE WITH EVO MFG PRODUCTS MAY NOT BE ENOUGH TO PROPERLY COMPLETE THESE TASKS. SOME OF EVO MFG PRODUCTS MAY REQUIRE TWO OR MORE PEOPLE TO INSTALL SAFELY AND CORRECTLY. DO NOT ATTEMPT ALONE, ALWAYS ENLIST THE HELP OF TRAINED PROFESSIONAL WHEN NEEDED.**

**Notes: Set Up Before installation**

**Make sure to start with the standard unmodified hard top.**

**Clean hard top and make sure water gutter is clean and clear of any debris.**

**Keep all mounting bolts loose (installed but not torqued) we will torque later at the end of complete installation**

**READ BEFORE INSTALL:**

It is generally a good idea to apply Loctite to all threaded bolts.

ALWAYS wear safety glasses and other approved safety gear when working on a vehicle.

All supplied bolts torqued according to chart at end of instruction.

It is recommended all installation be performed by a trained professional. Some modification may have to be done.

This rack has a distributed dynamic load rating of 70kg / 154lbs. Applying a bead of RTV Silicone in drip rail before inserting rack rails is advised for higher loads/speeds. It is advised to not carry items at high speeds that can create lift (upward force due to wind) such as but not limited to kayaks and surfboards etc.



Parts included: Table below shows black (painted) trail roof rack.

Description	#	Part #	Quantity
Lower T Slats	1	EVO-12366B	8
Front Plate	2	EVO-12365B	1
Passenger Side Main Plate	3	EVO-12363B	1
Driver Side Main Plate	4	EVO-12362B	1
Rear Plate	5	EVO-12364B	1
Upper L Slat	6	EVO-12367B	5
Outer Mount Bracket Assembly	7	EVO-12368B	4
Inner/Upper Main Mount	7	EVO-12369B	4
Inner Bolt Tab	7	EVO-12370B	4
Heavy Duty Rubber Trim	8	900432	2
Upper Lip Rubber Trim	8	900433	4
Hardware Bag	9	770085	1





#### Recommended Tools:

- Nutsert tool (5/6-18)
  - Loctite
  - Rubber Mallet
  - Allen Keys
- 



#### Safety Steps for installation

- For installing EVO MFG products always use wheel chokes to block rear tires from rolling.
  - Always make sure you have everything necessary ready before install.
  - If you have to, carefully lift front of vehicle by front frame rails extending suspension until tires leave the ground, place frame on approved jack stands for vehicle. Verify all lines/wires are not over extended.
  - Remove tires if needed for easier install.
  - Make sure to wear safety equipment (eye protection, hand protection, foot protection etc.) at all times during installation.
  - Make sure all safety precautions have been taken.
  - Always check and replace any part of vehicle that is worn or broken before starting install.
  - Do not mix anything EVO with weaker alternatives.
  - It is generally a good idea to apply liquid threadlock to all bolts.
  - Tighten included hardware to torque specifications in bottom table unless it is otherwise specified, factory bolts should be torqued to factory Jeep specifications.
- 







## **FRONT INSTALL**

1. Begin by assembling the 3 inner slat assemblies. Each will consist of 2 "L" Slat pieces and 1 "T" slat pieces.
2. Using supplied  $\frac{1}{4}$ " bolt, washer and flange nuts, assemble 3 sets of inner slat assemblies by installing 6 bolts on the 6 inner holes of each. The end 2 holes on each end of each slat assembly should remain without bolts at this time.



**Tighten bolts of all 3 assemblies.**

---



3. Assemble the front and rear slat assemblies next. These will consist of 1 “L” Slat piece and 1 “T” flat piece.

4. Using supplied ¼” bolt, washer and flange nuts, assemble 2 sets of end (front and rear) slat assemblies by installing bolts on the 3 inner holes only. The end 2 holes and other middle 3 holes should remain without bolts at this time.

5. Tighten 3 bolts on both front and rear assemblies. Front and rear assemblies are duplicates of each other.

---



**On a flat surface**

6. Loosely assemble the perimeter sections of the rack. This consists of the Driver side plate, Passenger side plate, Front plate and Rear plate.

Using the supplied ¼” bolts, washer and flange nut loosely install 2 sets at each corner.

---





8. Using supplied  $\frac{1}{4}$ " bolt, washer and flange nuts, loosely install the 3 pre-assembled middle cross bar slats, front and rear cross bar slat.

All cross bar assemblies should be installed on the underside of the perimeter parts.

---



10. Using supplied  $\frac{5}{16}$ " bolt, washer, flange nut. Install upper bolt plate and lower bolt plate as shown. Install upper bolt plate from inside of main plate through slot toward the outside. Tighten bolts. Do this at all 4 ends.
- 





11. Install edge trimming on the edge of the 4  
outer rail mounting plate lips.
- 



1. Using your nutsert installation tool and  
tool specific installation guide, install  
nutserts onto the outer rail mounting  
plate. Use picture as reference.
- 





**Upper bolt plate should be installed to the inside of main side plate and pass through large slot. See picture to the right**

---



**This may require 2 or more people.**

12. With rack loosely assembled and upside down. Flip over if needed. Install/press on edge trim on driver side plate edge end to end. Trim and use remainder to repeat on passenger side plate.
13. Flip rack with top up. Lift over jeep hard top and set into place on into the drip rail. Rack should be placed where the rear edge of the side plates line up with the rear of the drip rail. Use line on picture as reference.

**The rack may require a slight push to fully seat into drip rail.**

---





14. Insert bolt and washer from top down of upper mounting plate and thread into outer rail mount. Lower edge with trim should be grabbing underside of hardtop drip rail.

**Note:** Do not over tighten this bolt. Snug to 15 lb/ft. Repeat on all 4 mounting ends.

---



15. Tighten all bolts.

---





After Install:

- Tighten all bolts securing purchased parts to specified locations.
- After completing installation using provided instructions, go through all steps again to make sure nothing was missed, not tightened or improperly assembled.
- Some components may need to be purchased separately.
- Check turn signals, headlights, fog lights (if applicable), taillights, blinkers and windshield wipers.
- Adjust mirrors, speedometer and headlights if needed.
- Make sure all gauges are fully operational.
- Drive the vehicle slowly for a couple minutes, looking and listening for abnormal noises while driving. After modification of a vehicle there will be differences in driving experiences and capabilities, be mindful of that.
- Inspect and Retorque all Bolts after 500 miles of completed installation and regularly thereafter.
- Some modification may be required.

Recommended Torque:

Size	Grade 2		Grade 5		Grade 8		18-8 S/S	
	Coarse	Fine	Coarse	Fine	Coarse	Fine	Coarse	Fine
<b>#4*</b>	-	-	-	-	-	-	5.2	-
<b>#6*</b>	-	-	-	-	-	-	9.6	-
<b>#8*</b>	-	-	-	-	-	-	19.8	-
<b>#10*</b>	-	-	-	-	-	-	22.8	31.7
<b>1/4</b>	4	4.7	6.3	7.3	9	10	6.3	7.8
<b>5/16</b>	8	9	13	14	18	20	11	11.8
<b>3/8</b>	15	17	23	26	33	37	20	22
<b>7/16</b>	24	27	37	41	52	58	31	33
<b>1/2</b>	37	41	57	64	80	90	43	45
<b>9/16</b>	53	59	82	91	115	129	57	63
<b>5/8</b>	73	83	112	128	159	180	93	104
<b>3/4</b>	125	138	200	223	282	315	128	124
<b>7/8</b>	129	144	322	355	454	501	194	193
<b>1+</b>	188	210	483	541	682	764	287	289



EVO Manufacturing  
Jeep Wrangler JLU 2018+  
JL Unlimited Trail Roof Rack  
EVO-3038, EVO-3038B kits







Before starting installation procedure please read <http://evomfg.com>Returns-Warranties-Shipping>

**CAREFULLY READ AND FOLLOW ALL INSTRUCTIONS IN THIS MANUAL AND KEEP FOR FUTURE REFERENCE. IF YOU HAVE ANY QUESTIONS ABOUT THE PRODUCT CALL EVO MANUFACTURING. FAILURE TO FOLLOW GUIDELINES COULD RESULT IN MALFUNCTION OF PARTS OR INJURY. PLEASE HAVE A TRAINED PROFESSIONAL ASSIST WITH OR INSTALL ALL PRODUCTS. INSTALLING EVO MFG PRODUCTS OR KITS DEMANDS SPECIFIC KNOWLEDGE, TOOLS AND EXPERIENCE. GENERAL KNOWLEDGE OF HOW TO USE LATER SPECIFIED TOOLS AND/OR LIMITED EXPERIENCE WITH EVO MFG PRODUCTS MAY NOT BE ENOUGH TO PROPERLY COMPLETE THESE TASKS. SOME OF EVO MFG PRODUCTS MAY REQUIRE TWO OR MORE PEOPLE TO INSTALL SAFELY AND CORRECTLY. DO NOT ATTEMPT ALONE, ALWAYS ENLIST THE HELP OF TRAINED PROFESSIONAL WHEN NEEDED.**

**Notes: Set Up Before installation**

**Make sure to start with the standard unmodified hard top.**

**Clean hard top and make sure water gutter is clean and clear of any debris.**

**Keep all mounting bolts loose (installed but not torqued) we will torque later at the end of complete installation**

**READ BEFORE INSTALL:**

It is generally a good idea to apply Loctite to all threaded bolts.

ALWAYS wear safety glasses and other approved safety gear when working on a vehicle.

All supplied bolts torqued according to chart at end of instruction.

It is recommended all installation be performed by a trained professional. Some modification may have to be done.

This rack has a distributed dynamic load rating of 70kg / 154lbs. Applying a bead of RTV Silicone in drip rail before inserting rack rails is advised for higher loads/speeds. It is advised to not carry items at high speeds that can create lift (upward force due to wind) such as but not limited to kayaks and surfboards etc.



Parts included: Table below shows black (painted) trail roof rack.

Description	#	Part #	Quantity
Lower T Slats	1	EVO-12366B	8
Front Plate	2	EVO-12365B	1
Passenger Side Main Plate	3	EVO-12363B	1
Driver Side Main Plate	4	EVO-12362B	1
Rear Plate	5	EVO-12364B	1
Upper L Slat	6	EVO-12367B	5
Outer Mount Bracket Assembly	7	EVO-12368B	4
Inner/Upper Main Mount	7	EVO-12369B	4
Inner Bolt Tab	7	EVO-12370B	4
Heavy Duty Rubber Trim	8	900432	2
Upper Lip Rubber Trim	8	900433	4
Hardware Bag	9	770085	1





#### Recommended Tools:

- Nutsert tool (5/6-18)
  - Loctite
  - Rubber Mallet
  - Allen Keys
- 



#### Safety Steps for installation

- For installing EVO MFG products always use wheel chokes to block rear tires from rolling.
  - Always make sure you have everything necessary ready before install.
  - If you have to, carefully lift front of vehicle by front frame rails extending suspension until tires leave the ground, place frame on approved jack stands for vehicle. Verify all lines/wires are not over extended.
  - Remove tires if needed for easier install.
  - Make sure to wear safety equipment (eye protection, hand protection, foot protection etc.) at all times during installation.
  - Make sure all safety precautions have been taken.
  - Always check and replace any part of vehicle that is worn or broken before starting install.
  - Do not mix anything EVO with weaker alternatives.
  - It is generally a good idea to apply liquid threadlock to all bolts.
  - Tighten included hardware to torque specifications in bottom table unless it is otherwise specified, factory bolts should be torqued to factory Jeep specifications.
- 





## **FRONT INSTALL**

1. Begin by assembling the 3 inner slat assemblies. Each will consist of 2 "L" Slat pieces and 1 "T" slat pieces.
2. Using supplied  $\frac{1}{4}$ " bolt, washer and flange nuts, assemble 3 sets of inner slat assemblies by installing 6 bolts on the 6 inner holes of each. The end 2 holes on each end of each slat assembly should remain without bolts at this time.



**Tighten bolts of all 3 assemblies.**

---



3. Assemble the front and rear slat assemblies next. These will consist of 1 “L” Slat piece and 1 “T” flat piece.

4. Using supplied ¼” bolt, washer and flange nuts, assemble 2 sets of end (front and rear) slat assemblies by installing bolts on the 3 inner holes only. The end 2 holes and other middle 3 holes should remain without bolts at this time.

5. Tighten 3 bolts on both front and rear assemblies. Front and rear assemblies are duplicates of each other.

---



**On a flat surface**

6. Loosely assemble the perimeter sections of the rack. This consists of the Driver side plate, Passenger side plate, Front plate and Rear plate.

Using the supplied ¼” bolts, washer and flange nut loosely install 2 sets at each corner.

---





8. Using supplied  $\frac{1}{4}$ " bolt, washer and flange nuts, loosely install the 3 pre-assembled middle cross bar slats, front and rear cross bar slat.

All cross bar assemblies should be installed on the underside of the perimeter parts.

---



10. Using supplied  $\frac{5}{16}$ " bolt, washer, flange nut. Install upper bolt plate and lower bolt plate as shown. Install upper bolt plate from inside of main plate through slot toward the outside. Tighten bolts. Do this at all 4 ends.
- 





**Upper bolt plate should be installed to the inside of main side plate and pass through large slot. See picture to the right**

---



**This may require 2 or more people.**

11. With rack loosely assembled and upside down. Flip over if needed. Install/press on edge trim on driver side plate edge end to end. Trim and use remainder to repeat on passenger side plate.
12. Flip rack with top up. Lift over jeep hard top and set into place on into the drip rail. Rack should be placed where the rear edge of the side plates line up with the rear of the drip rail. Use line on picture as reference.

**The rack may require a slight push to fully seat into drip rail.**

---





13. Install edge trimming on the edge of  
the 4 outer rail mounting plate lips.

---



14. Insert bolt and washer from top down  
of upper mounting plate and thread  
into outer rail mount. Lower edge  
with trim should be grabbing  
underside of hardtop drip rail.

**Note:** Do not over tighten this bolt. Snug  
to 15 lb/ft. Repeat on all 4 mounting  
ends.

---







15. Tighten all bolts.



After Install:

- Tighten all bolts securing purchased parts to specified locations.
- After completing installation using provided instructions, go through all steps again to make sure nothing was missed, not tightened or improperly assembled.
- Some components may need to be purchased separately.
- Check turn signals, headlights, fog lights (if applicable), taillights, blinkers and windshield wipers.
- Adjust mirrors, speedometer and headlights if needed.
- Make sure all gauges are fully operational.
- Drive the vehicle slowly for a couple minutes, looking and listening for abnormal noises while driving. After modification of a vehicle there will be differences in driving experiences and capabilities, be mindful of that.
- Inspect and Retorque all Bolts after 500 miles of completed installation and regularly thereafter.
- Some modification may be required.



Recommended Torque:

Size	Grade 2		Grade 5		Grade 8		18-8 S/S	
	Coarse	Fine	Coarse	Fine	Coarse	Fine	Coarse	Fine
<b>#4*</b>	-	-	-	-	-	-	5.2	-
<b>#6*</b>	-	-	-	-	-	-	9.6	-
<b>#8*</b>	-	-	-	-	-	-	19.8	-
<b>#10*</b>	-	-	-	-	-	-	22.8	31.7
<b>1/4</b>	4	4.7	6.3	7.3	9	10	6.3	7.8
<b>5/16</b>	8	9	13	14	18	20	11	11.8
<b>3/8</b>	15	17	23	26	33	37	20	22
<b>7/16</b>	24	27	37	41	52	58	31	33
<b>1/2</b>	37	41	57	64	80	90	43	45
<b>9/16</b>	53	59	82	91	115	129	57	63
<b>5/8</b>	73	83	112	128	159	180	93	104
<b>3/4</b>	125	138	200	223	282	315	128	124
<b>7/8</b>	129	144	322	355	454	501	194	193
<b>1†</b>	188	210	483	541	682	764	287	289



EVO Manufacturing

Jeep Wrangler JL 2018+ 3.6L ONLY

EVO MFG JL 3.6L PROTEK ENGINE, TRANS SKID

EVO-3039B





Before starting installation procedure please read <http://evomfg.com>Returns-Warranties-Shipping>

**CAREFULLY READ AND FOLLOW ALL INSTRUCTIONS IN THIS MANUAL AND KEEP FOR FUTURE REFERENCE. IF YOU HAVE ANY QUESTIONS ABOUT THE PRODUCT CALL EVO MANUFACTURING. FAILURE TO FOLLOW GUIDELINES COULD RESULT IN MALFUNCTION OF PARTS OR INJURY. PLEASE HAVE A TRAINED PROFESSIONAL ASSIST WITH OR INSTALL ALL PRODUCTS. INSTALLING EVO MFG PRODUCTS OR KITS DEMANDS SPECIFIC KNOWLEDGE, TOOLS AND EXPERIENCE. GENERAL KNOWLEDGE OF HOW TO USE LATER SPECIFIED TOOLS AND/OR LIMITED EXPERIENCE WITH EVO MFG PRODUCTS MAY NOT BE ENOUGH TO PROPERLY COMPLETE THESE TASKS. SOME OF EVO MFG PRODUCTS MAY REQUIRE TWO OR MORE PEOPLE TO INSTALL SAFELY AND CORRECTLY. DO NOT ATTEMPT ALONE, ALWAYS ENLIST THE HELP OF TRAINED PROFESSIONAL WHEN NEEDED.**

**Notes: Set Up Before installation**

**Recommended working with vehicle suspended using jack stands or with wheels chocked.**

**The EVO 3039B is compatible with JLU 3.6L only.**

**EVO-3039B is compatible with all EVO MFG JLU Suspension Systems.**

**No drilling, cutting or welding required.**

**Retain all bolts removed in process, they will be reused.**

**READ BEFORE INSTALL:**

1" or larger front bumpstop extensions are recommended to be installed with this skid plate system.

Reuse of bolts already installed on Jeep will be necessary.

ALWAYS wear safety glasses and other approved safety gear when working on a vehicle.

Some grinding / sanding may be required to achieve your desired fitment.

It is recommended all installation be performed by a trained professional. Some modification may have to be done.

If lifting vehicle do so carefully and support vehicle with approved jack stands.



Parts included: Table below shows Jeep JL PROTEK ENGINE, TRANS SKID

Description	#	Part #	Quantity
Passenger Mount	1	EVO-12373B	1
Hardware	2	EVO-770086	1
Driver Mount	3	EVO-12372B	1
Engine/Trans Skid	4	EVO-12371B	1

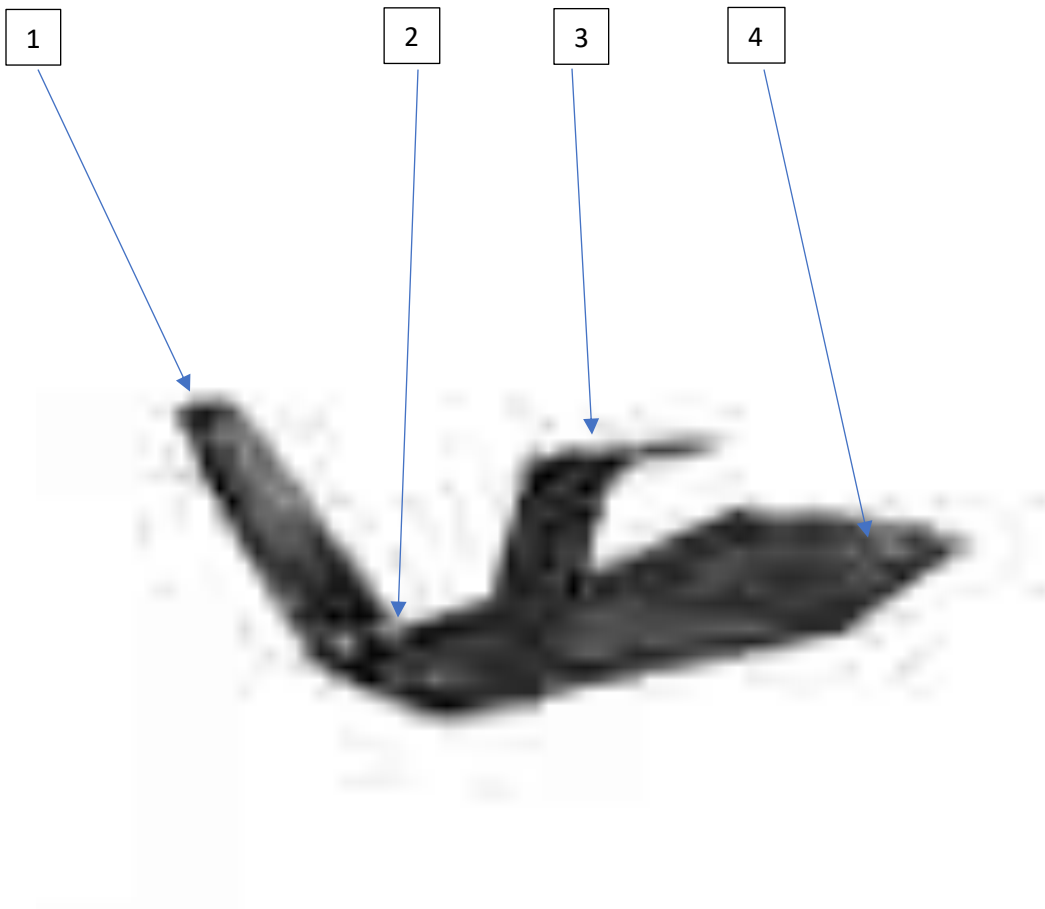



### Recommended Tools:

- Wrench/Socket Wrench
  - Loctite
- 



### Safety Steps for installation

- For installing EVO MFG products always use wheel chokes to block rear tires from rolling.
- Always make sure you have everything necessary ready before install.
- If you have to, carefully lift front of vehicle by front frame rails extending suspension until tires leave the ground, place frame on approved jack stands for vehicle. Verify all lines/wires are not over extended.
- Remove tires if needed for easier install.
- Make sure to wear safety equipment (eye protection, hand protection, foot protection etc.) at all times during installation.
- Make sure all safety precautions have been taken.
- Always check and replace any part of vehicle that is worn or broken before starting install.
- Do not mix anything EVO with weaker alternatives.
- It is generally a good idea to apply liquid threadlock to all bolts.
- Tighten included hardware to torque specifications in bottom table unless it is otherwise specified, factory bolts should be torqued to factory Jeep specifications.
- Welding creates a very bright arc that should not be looked at without an approved protective shield/clothing. Welded surfaces and areas in their vicinity will be very hot for a long time. All welding should be performed by a professional. USE CAUTION





After putting vehicle in park, on a flat surface, chalked the tires and turned off the vehicle.

1. Remove forward most crossbar, forward of the transmission crossmember, by removing the 3 bolts, 2 in frame and 1 in transmission crossmember. Discard, this will not be reused. **Retain all bolts.**
2. Remove 2 screws holding transfer case skid plate to transmission crossmember.
3. Loosen the other 2 bolts in transfer case skid plate a few turns until front lowers  $\frac{1}{2}$ ". Do not remove skid plate.





4. Slide EVO MFG engine/transmission skid plate between lower factory transfer case skid and transmission crossmember (sandwiching EVO Skid).
  5. Reinstall the removed 2 bolts into transmission crossmember.
  6. Using supplied hardware, loosely install the driver side (larger) forward support to hole in frame bracket just below the motor mount. Bolt from top down, EVO bracket on underside of motor mount bracket.
- 



7. Using supplied hardware, loosely install the driver side (larger) forward support to hole in frame bracket just below the motor mount. Bolt from top down, EVO bracket on underside of motor mount bracket.
- 







8. Using supplied hardware, loosely install the passenger side (smaller) forward support to hole in frame bracket just below the motor mount. Bolt from top down, EVO MFG bracket on underside of motor mount bracket.
  9. Using supplied hardware, loosely install the forward supports to main engine /trans skid. Forward support mounts should be mounted to the outside of the engine/trans skid tab
- 



---

**Once all bolts have been loosely fitted, tighten to specified torque using table below**



After Install:

- Tighten all bolts securing purchased parts to specified locations.
- After completing installation using provided instructions, go through all steps again to make sure nothing was missed, not tightened or improperly assembled.
- Some components may need to be purchased separately.
- Check turn signals, headlights, fog lights (if applicable), taillights, blinkers and windshield wipers.
- Adjust mirrors, speedometer and headlights if needed.
- Make sure all gauges are fully operational.
- Drive the vehicle slowly for a couple minutes, looking and listening for abnormal noises while driving. After modification of a vehicle there will be differences in driving experiences and capabilities, be mindful of that.
- Inspect and Retorque all Bolts after 500 miles of completed installation and regularly thereafter.
- Some modification may be required.

Recommended Torque:

Size	Grade 2		Grade 5		Grade 8		18-8 S/S	
	Coarse	Fine	Coarse	Fine	Coarse	Fine	Coarse	Fine
<b>#4*</b>	-	-	-	-	-	-	5.2	-
<b>#6*</b>	-	-	-	-	-	-	9.6	-
<b>#8*</b>	-	-	-	-	-	-	19.8	-
<b>#10*</b>	-	-	-	-	-	-	22.8	31.7
<b>1/4</b>	4	4.7	6.3	7.3	9	10	6.3	7.8
<b>5/16</b>	8	9	13	14	18	20	11	11.8
<b>3/8</b>	15	17	23	26	33	37	20	22
<b>7/16</b>	24	27	37	41	52	58	31	33
<b>1/2</b>	37	41	57	64	80	90	43	45
<b>9/16</b>	53	59	82	91	115	129	57	63
<b>5/8</b>	73	83	112	128	159	180	93	104
<b>3/4</b>	125	138	200	223	282	315	128	124
<b>7/8</b>	129	144	322	355	454	501	194	193
<b>1†</b>	188	210	483	541	682	764	287	289



EVO Manufacturing

Jeep Wrangler JLU 2018+ 3.6L ONLY

EVO MFG JLU 3.6L PROTEK EXHAUST LOOP SKID EVO-3040B

EVO-3040B



**Requires EVO Protek Trans/Engine Skid (EVO-3039B)**



Before starting installation procedure please read <http://evomfg.com>Returns-Warranties-Shipping>

**CAREFULLY READ AND FOLLOW ALL INSTRUCTIONS IN THIS MANUAL AND KEEP FOR FUTURE REFERENCE. IF YOU HAVE ANY QUESTIONS ABOUT THE PRODUCT CALL EVO MANUFACTURING. FAILURE TO FOLLOW GUIDELINES COULD RESULT IN MALFUNCTION OF PARTS OR INJURY. PLEASE HAVE A TRAINED PROFESSIONAL ASSIST WITH OR INSTALL ALL PRODUCTS. INSTALLING EVO MFG PRODUCTS OR KITS DEMANDS SPECIFIC KNOWLEDGE, TOOLS AND EXPERIENCE. GENERAL KNOWLEDGE OF HOW TO USE LATER SPECIFIED TOOLS AND/OR LIMITED EXPERIENCE WITH EVO MFG PRODUCTS MAY NOT BE ENOUGH TO PROPERLY COMPLETE THESE TASKS. SOME OF EVO MFG PRODUCTS MAY REQUIRE TWO OR MORE PEOPLE TO INSTALL SAFELY AND CORRECTLY. DO NOT ATTEMPT ALONE, ALWAYS ENLIST THE HELP OF TRAINED PROFESSIONAL WHEN NEEDED.**

**Notes: Set Up Before installation**

**Keep factory bolts that are removed, we will reuse the factory hardware**

**EVO-3039B is compatible with all EVO MFG JLU Suspension Systems.**

**No drilling, cutting or welding required.**

**Clean underbody area, will make install much easier.**

**Keep all mounting bolts loose (installed but not torqued) we will torque later at the end of complete installation**

**READ BEFORE INSTALL:**

Put vehicle in park on a flat surface and chalk tires and turn off vehicle.

It is generally a good idea to apply Loctite to all threaded bolts.

ALWAYS wear safety glasses and other approved safety gear when working on a vehicle.

All supplied bolts torqued according to chart at end of instruction.

It is recommended all installation be performed by a trained professional. Some modification may have to be done.

This Skid is made to protect the exhaust loop while also clearing the front driveshaft, make sure after installation (using all safety precautions necessary, some precautionary measures are stated below under Safety Steps for Installation) that the drive shaft does in fact clear the skid. Driveshaft contact with skid plate could cause damage to driveshaft.



Parts included: Table below shows black (painted) trail roof rack.

Description	#	Part #	Quantity
EVO Exhaust Loop Skid	1	EVO-12374B	1
HHCS 3/8"	2	EVO-900022	1
SAE Washer 3/8"	3	EVO-900214	1
Limit Strap Nut	4	EVO-12377CZ	1
Stover Lock Nut	5	EVO-900221	1
SAE Washer 7/16"	6	EVO-900215	1
HHCS 1/2"	7	EVO-900038	1

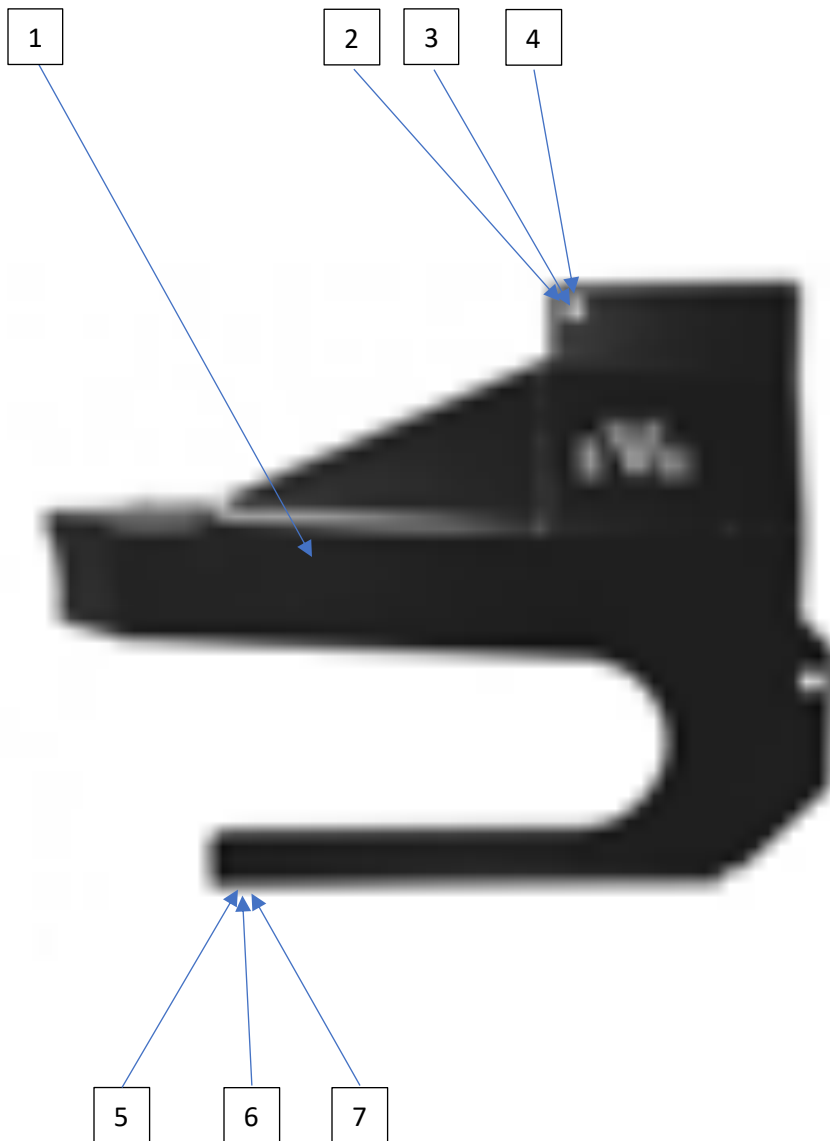



#### Recommended Tools:

- Wrenches (English/metric)
  - Loctite
  - Impact wrench with sockets
- 



#### Safety Steps for installation

- For installing EVO MFG products always use wheel chokes to block rear tires from rolling.
  - Always make sure you have everything necessary ready before install.
  - If you have to, carefully lift front of vehicle by front frame rails extending suspension until tires leave the ground, place frame on approved jack stands for vehicle. Verify all lines/wires are not over extended.
  - Remove tires if needed for easier install.
  - Make sure to wear safety equipment (eye protection, hand protection, foot protection etc.) at all times during installation.
  - Make sure all safety precautions have been taken.
  - Always check and replace any part of vehicle that is worn or broken before starting install.
  - Do not mix anything EVO with weaker alternatives.
  - It is generally a good idea to apply liquid threadlock to all bolts.
  - Tighten included hardware to torque specifications in bottom table unless it is otherwise specified, factory bolts should be torqued to factory Jeep specifications.
- 





## INSTALL

After putting vehicle in park, on a flat surface, chalked the tires and turned off the vehicle.

1. Remove nut from bolt on driver side control arm mount on frame end. Keep bolt in place and **retain nut, will be used later for reinstallation.**
- 





2. Insert flag nut (limit strap nut) into oval slot in frame (on drivers side in front of transfer case crossmember) and line up with hole.
- 



Remove the bolts at the forward end of transfer case skid plate.

3. Slide the skid plate oriented as pictured and reinstall the bolts taken from the forward end of transfer case skid plate. Guide front of skid plate where the hole lines up with the driver side frame control arm bolt. Loosely secure all bolts.
- 



4. Using supplied hardware, install washer onto HHCS 1/2" and HHCS 3/8" bolts.
  5. Install HHCS 1/2" bolt with a washer into frame hole in bracket, install HHCS 3/8" bolt and washer through the holes that marry the exhaust loop skid to the engine/trans skid.
  6. Once bolt is inserted through the two skid plate marrying holes then put the supplied Stover lock nut on. Tighten but do not torque down.
- 







7. Using the factory hardware from the frame side upper control arm bracket, reinsert bolt through control arm bracket, then control arm, finishing through the skid plate hole. Install factory nut onto bolt and tighten but not torque. **Wait until vehicle is under its own weight and on level ground before torquing down all bolts.**
- 



- **All bolts need to be tightened after procedure, make sure to tighten bolts after putting vehicle safely on ground, chalking tires, and in park, under vehicles own weight at ride height.**

After Installation :

- secure purchased parts to specified locations.
- After completing installation using provided instructions, go through all steps again to make sure nothing was missed, not tightened or improperly assembled.
- Some components may need to be purchased separately.
- Check turn signals, headlights, fog lights (if applicable), taillights, blinkers and windshield wipers.
- Adjust mirrors, speedometer and headlights if needed.
- Make sure all gauges are fully operational.
- Drive the vehicle slowly for a couple minutes, looking and listening for abnormal noises while driving. After modification of a vehicle there will be differences in driving experiences and capabilities, be mindful of that.
- Inspect and Retorque all Bolts after 500 miles of completed installation and regularly thereafter.
- Some modification may be required.



Recommended Torque:

Size	Grade 2		Grade 5		Grade 8		18-8 S/S	
	Coarse	Fine	Coarse	Fine	Coarse	Fine	Coarse	Fine
<b>#4*</b>	-	-	-	-	-	-	5.2	-
<b>#6*</b>	-	-	-	-	-	-	9.6	-
<b>#8*</b>	-	-	-	-	-	-	19.8	-
<b>#10*</b>	-	-	-	-	-	-	22.8	31.7
<b>1/4</b>	4	4.7	6.3	7.3	9	10	6.3	7.8
<b>5/16</b>	8	9	13	14	18	20	11	11.8
<b>3/8</b>	15	17	23	26	33	37	20	22
<b>7/16</b>	24	27	37	41	52	58	31	33
<b>1/2</b>	37	41	57	64	80	90	43	45
<b>9/16</b>	53	59	82	91	115	129	57	63
<b>5/8</b>	73	83	112	128	159	180	93	104
<b>3/4</b>	125	138	200	223	282	315	128	124
<b>7/8</b>	129	144	322	355	454	501	194	193
<b>1†</b>	188	210	483	541	682	764	287	289



EVO Manufacturing

Jeep Wrangler JL and JT Gladiator 2018+

EVO-3042B Jeep JL/JT Front Axle FAD/CAD Skid





Before starting installation procedure please read <http://evomfg.com>Returns-Warranties-Shipping>

**CAREFULLY READ AND FOLLOW ALL INSTRUCTIONS IN THIS MANUAL AND KEEP FOR FUTURE REFERENCE. IF YOU HAVE ANY QUESTIONS ABOUT THE PRODUCT CALL EVO MANUFACTURING. FAILURE TO FOLLOW GUIDELINES COULD RESULT IN MALFUNCTION OF PARTS OR INJURY. PLEASE HAVE A TRAINED PROFESSIONAL ASSIST WITH OR INSTALL ALL PRODUCTS. INSTALLING EVO MFG PRODUCTS OR KITS DEMANDS SPECIFIC KNOWLEDGE, TOOLS AND EXPERIENCE. GENERAL KNOWLEDGE OF HOW TO USE LATER SPECIFIED TOOLS AND/OR LIMITED EXPERIENCE WITH EVO MFG PRODUCTS MAY NOT BE ENOUGH TO PROPERLY COMPLETE THESE TASKS. SOME OF EVO MFG PRODUCTS MAY REQUIRE TWO OR MORE PEOPLE TO INSTALL SAFELY AND CORRECTLY. DO NOT ATTEMPT ALONE, ALWAYS ENLIST THE HELP OF TRAINED PROFESSIONAL WHEN NEEDED.**

**Notes: Set Up Before installation**

**Make sure FAD/CAD wires are not pinched**

**Keep factory hardware, will be reused during the install process**

**Keep all mounting bolts loose (installed but not torqued) we will torque later at the end of complete installation**

**READ BEFORE INSTALL:**

It is generally a good idea to apply Loctite to all threaded bolts.

ALWAYS wear safety glasses and other approved safety gear when working on a vehicle.

All supplied bolts torqued according to chart at end of instruction.

It is recommended all installation be performed by a trained professional. Some modification may have to be done.

Do not pinch/cut into wires

Damage to wires could result into changes to FAD/CAD system



Parts included: Table below shows black (painted) EVO MFG FAD/CAD Skid.

Description	#	Part #	Quantity
FAD/CAD Skid	1	EVO-12378	1





### Recommended Tools:

- Wrench/socket set
  - Loctite
- 



### Safety Steps for installation

- For installing EVO MFG products always use wheel chokes to block rear tires from rolling.
  - Always make sure you have everything necessary ready before install.
  - If you have to, carefully lift front of vehicle by front frame rails extending suspension until tires leave the ground, place frame on approved jack stands for vehicle. Verify all lines/wires are not over extended.
  - Remove tires if needed for easier install.
  - Make sure to wear safety equipment (eye protection, hand protection, foot protection etc.) at all times during installation.
  - Make sure all safety precautions have been taken.
  - Always check and replace any part of vehicle that is worn or broken before starting install.
  - Do not mix anything EVO with weaker alternatives.
  - It is generally a good idea to apply liquid threadlock to all bolts.
  - Tighten included hardware to torque specifications in bottom table unless it is otherwise specified, factory bolts should be torqued to factory Jeep specifications.
- 





## **FRONT INSTALL**

1. Safely park vehicle on flat surface, put in park and chalk tires.
  2. Remove bolt connected to axle side of steering stabilizer and retain bolt for future use.
  3. Remove lower bolt on bottom side of the steering stabilizer bracket. Retain.
- 





4. Remove upper factory FAD skid bolt directly above right side control arm bracket. Retain.
  5. Keep factory skid in factory position with all bolts removed. Will be installing EVO MFG FAD/CAD skid over factory skid.
- 



6. Slide provided EVO FAD/CAD skid over factory FAD skid.
  7. Using factory hardware reinstall all 3 bolts at original locations. Torque to factory specifications
- 



#### After Install:

- Tighten all bolts securing purchased parts to specified locations.
- After completing installation using provided instructions, go through all steps again to make sure nothing was missed, not tightened or improperly assembled.
- Some components may need to be purchased separately.
- Check turn signals, headlights, fog lights (if applicable), taillights, blinkers and windshield wipers.
- Adjust mirrors, speedometer and headlights if needed.
- Make sure all gauges are fully operational.
- Drive the vehicle slowly for a couple minutes, looking and listening for abnormal noises while driving. After modification of a vehicle there will be differences in driving experiences and capabilities, be mindful of that.
- Inspect and Retorque all Bolts after 500 miles of completed installation and regularly thereafter.
- Some modification may be required.





Recommended Torque:

Size	Grade 2		Grade 5		Grade 8		18-8 S/S	
	Coarse	Fine	Coarse	Fine	Coarse	Fine	Coarse	Fine
<b>#4*</b>	-	-	-	-	-	-	5.2	-
<b>#6*</b>	-	-	-	-	-	-	9.6	-
<b>#8*</b>	-	-	-	-	-	-	19.8	-
<b>#10*</b>	-	-	-	-	-	-	22.8	31.7
<b>1/4</b>	4	4.7	6.3	7.3	9	10	6.3	7.8
<b>5/16</b>	8	9	13	14	18	20	11	11.8
<b>3/8</b>	15	17	23	26	33	37	20	22
<b>7/16</b>	24	27	37	41	52	58	31	33
<b>1/2</b>	37	41	57	64	80	90	43	45
<b>9/16</b>	53	59	82	91	115	129	57	63
<b>5/8</b>	73	83	112	128	159	180	93	104
<b>3/4</b>	125	138	200	223	282	315	128	124
<b>7/8</b>	129	144	322	355	454	501	194	193
<b>1†</b>	188	210	483	541	682	764	287	289



EVO Manufacturing  
Jeep Wrangler JL/JT Gladiator  
JL/JT Trackbars  
EVO- 3047B, 3048B, 3049B





Before starting installation procedure please read <http://evomfg.com>Returns-Warranties-Shipping>

**CAREFULLY READ AND FOLLOW ALL INSTRUCTIONS IN THIS MANUAL AND KEEP FOR FUTURE REFERENCE. IF YOU HAVE ANY QUESTIONS ABOUT THE PRODUCT CALL EVO MANUFACTURING. FAILURE TO FOLLOW GUIDELINES COULD RESULT IN MALFUNCTION OF PARTS OR INJURY. PLEASE HAVE A TRAINED PROFESSIONAL ASSIST WITH OR INSTALL ALL PRODUCTS. INSTALLING EVO MFG PRODUCTS OR KITS DEMANDS SPECIFIC KNOWLEDGE, TOOLS AND EXPERIENCE. GENERAL KNOWLEDGE OF HOW TO USE LATER SPECIFIED TOOLS AND/OR LIMITED EXPERIENCE WITH EVO MFG PRODUCTS MAY NOT BE ENOUGH TO PROPERLY COMPLETE THESE TASKS. SOME OF EVO MFG PRODUCTS MAY REQUIRE TWO OR MORE PEOPLE TO INSTALL SAFELY AND CORRECTLY. DO NOT ATTEMPT ALONE, ALWAYS ENLIST THE HELP OF TRAINED PROFESSIONAL WHEN NEEDED.**

**Notes: Set Up Before installation**

**This is a general instruction for this component kit.**

**Directions/pictures may vary for each specific install, use for reference only.**

**Keep all mounting bolts loose (installed but not torqued) we will torque later at the end of complete installation**

**STARTING LENGTH FOR JL/JT FRONT TRACK BAR CENTER TO CENTER, 34 1/4"**

**STARTING LENGTH FOR JL REAR TRACKBAR CENTER TO CENTER, 37 7/16"**

**STARTING LENGTH FOR JT REAR TRACKBAR CENTER TO CENTER, 33 9/16"**

**READ BEFORE INSTALL:**

ALL measurements stated above are starting points only, every vehicle is different. Professional alignment is recommended.

It is generally a good idea to apply Loctite to all threaded bolts.

ALWAYS wear safety glasses and other approved safety gear when working on a vehicle.

All supplied bolts torqued according to chart at end of instruction.

It is recommended all installation be performed by a trained professional. Some modification may have to be done.

Paint all unfinished surfaces after install is complete.



Parts included: Table below shows JL/JT Trackbars.

Description	#	Part #	Quantity
JL/JT Front Trackbar	1	3047B	1
JT Rear Trackbar	2	3049B	1
JL Rear Trackbar	3	3048B	1



**Note:** For JL/JT FRONT and JT REAR trackbars, adjustable end attaches at AXLE side. For JL REAR adjustable end goes to FRAME side.



#### **Recommended Tools:**

- Standard socket set w/ wrench
  - OR Standard wrench set
- 



#### **Safety Steps for installation**

- For installing EVO MFG products always use wheel chokes to block rear tires from rolling.
  - Always make sure you have everything necessary ready before install.
  - If you have to, carefully lift front of vehicle by front frame rails extending suspension until tires leave the ground, place frame on approved jack stands for vehicle. Verify all lines/wires are not over extended.
  - Remove tires if needed for easier install.
  - Make sure to wear safety equipment (eye protection, hand protection, foot protection etc.) at all times during installation.
  - Make sure all safety precautions have been taken.
  - Always check and replace any part of vehicle that is worn or broken before starting install.
  - Do not mix anything EVO with weaker alternatives.
  - It is generally a good idea to apply liquid threadlock to all bolts.
  - Tighten included hardware to torque specifications in bottom table unless it is otherwise specified, factory bolts should be torqued to factory Jeep specifications.
- 





After alignment is complete and no additional adjustments are to be made to control arms. Torque all 1" Jam Nuts to 250 ft/lbs and all 1-1/4" Jam Nuts torque to 300 ft/lbs. Regularly check all jam nuts and punch bolts on all control arms for proper torque/tightness. Failure to do so may cause premature wear of threads on arms.

## INSTALL:

1. With vehicle in park, on flat ground and emergency brake applied, remove the bolts on both ends of factory trackbar.
  2. Once factory trackbar has been removed, bolt new EVO MFG trackbar on ONLY TO THE FRAME SIDE.
  3. The trackbar will need to be guided into the bracket at the axle. For the front trackbars turn the steering wheel until trackbar bolts line up.
  4. Once trackbar lines up with hole in trackbar bracket on the axle side, insert factory bolt and loosely tighten bolt. Tighten bolts to specified torque.
- 





After Install:

- Tighten all bolts securing purchased parts to specified locations.
- After completing installation using provided instructions, go through all steps again to make sure nothing was missed, not tightened or improperly assembled.
- Some components may need to be purchased separately.
- Check turn signals, headlights, fog lights (if applicable), taillights, blinkers and windshield wipers.
- Adjust mirrors, speedometer and headlights if needed.
- Make sure all gauges are fully operational.
- Drive the vehicle slowly for a couple minutes, looking and listening for abnormal noises while driving. After modification of a vehicle there will be differences in driving experiences and capabilities, be mindful of that.
- Inspect and Retorque all Bolts after 500 miles of completed installation and regularly thereafter.
- Some modification may be required.

Recommended Torque:

Size	Grade 2		Grade 5		Grade 8		18-8 S/S	
	Coarse	Fine	Coarse	Fine	Coarse	Fine	Coarse	Fine
<b>#4*</b>	-	-	-	-	-	-	5.2	-
<b>#6*</b>	-	-	-	-	-	-	9.6	-
<b>#8*</b>	-	-	-	-	-	-	19.8	-
<b>#10*</b>	-	-	-	-	-	-	22.8	31.7
<b>1/4</b>	4	4.7	6.3	7.3	9	10	6.3	7.8
<b>5/16</b>	8	9	13	14	18	20	11	11.8
<b>3/8</b>	15	17	23	26	33	37	20	22
<b>7/16</b>	24	27	37	41	52	58	31	33
<b>1/2</b>	37	41	57	64	80	90	43	45
<b>9/16</b>	53	59	82	91	115	129	57	63
<b>5/8</b>	73	83	112	128	159	180	93	104
<b>3/4</b>	125	138	200	223	282	315	128	124
<b>7/8</b>	129	144	322	355	454	501	194	193
<b>1†</b>	188	210	483	541	682	764	287	289



EVO Manufacturing  
Jeep Wrangler JL/JT Gladiator  
JL/JT Trackbars  
EVO- 3047B, 3048B, 3049B







Before starting installation procedure please read <http://evomfg.com>Returns-Warranties-Shipping>

**CAREFULLY READ AND FOLLOW ALL INSTRUCTIONS IN THIS MANUAL AND KEEP FOR FUTURE REFERENCE. IF YOU HAVE ANY QUESTIONS ABOUT THE PRODUCT CALL EVO MANUFACTURING. FAILURE TO FOLLOW GUIDELINES COULD RESULT IN MALFUNCTION OF PARTS OR INJURY. PLEASE HAVE A TRAINED PROFESSIONAL ASSIST WITH OR INSTALL ALL PRODUCTS. INSTALLING EVO MFG PRODUCTS OR KITS DEMANDS SPECIFIC KNOWLEDGE, TOOLS AND EXPERIENCE. GENERAL KNOWLEDGE OF HOW TO USE LATER SPECIFIED TOOLS AND/OR LIMITED EXPERIENCE WITH EVO MFG PRODUCTS MAY NOT BE ENOUGH TO PROPERLY COMPLETE THESE TASKS. SOME OF EVO MFG PRODUCTS MAY REQUIRE TWO OR MORE PEOPLE TO INSTALL SAFELY AND CORRECTLY. DO NOT ATTEMPT ALONE, ALWAYS ENLIST THE HELP OF TRAINED PROFESSIONAL WHEN NEEDED.**

**Notes: Set Up Before installation**

**This is a general instruction for this component kit.**

**Directions/pictures may vary for each specific install, use for reference only.**

**Keep all mounting bolts loose (installed but not torqued) we will torque later at the end of complete installation**

**STARTING LENGTH FOR JL/JT FRONT TRACK BAR CENTER TO CENTER, 34 1/4"**

**STARTING LENGTH FOR JL REAR TRACKBAR CENTER TO CENTER, 37 7/16"**

**STARTING LENGTH FOR JT REAR TRACKBAR CENTER TO CENTER, 33 9/16"**

**READ BEFORE INSTALL:**

ALL measurements stated above are starting points only, every vehicle is different. Professional alignment is recommended.

It is generally a good idea to apply Loctite to all threaded bolts.

ALWAYS wear safety glasses and other approved safety gear when working on a vehicle.

All supplied bolts torqued according to chart at end of instruction.

It is recommended all installation be performed by a trained professional. Some modification may have to be done.

Paint all unfinished surfaces after install is complete.



Parts included: Table below shows JL/JT Trackbars.

Description	#	Part #	Quantity
JL/JT Front Trackbar	1	3047B	1
JT Rear Trackbar	2	3049B	1
JL Rear Trackbar	3	3048B	1



**Note:** For JL/JT FRONT and JT REAR trackbars, adjustable end attaches at AXLE side. For JL REAR adjustable end goes to FRAME side.



#### **Recommended Tools:**

- Standard socket set w/ wrench
  - OR Standard wrench set
- 



#### **Safety Steps for installation**

- For installing EVO MFG products always use wheel chokes to block rear tires from rolling.
  - Always make sure you have everything necessary ready before install.
  - If you have to, carefully lift front of vehicle by front frame rails extending suspension until tires leave the ground, place frame on approved jack stands for vehicle. Verify all lines/wires are not over extended.
  - Remove tires if needed for easier install.
  - Make sure to wear safety equipment (eye protection, hand protection, foot protection etc.) at all times during installation.
  - Make sure all safety precautions have been taken.
  - Always check and replace any part of vehicle that is worn or broken before starting install.
  - Do not mix anything EVO with weaker alternatives.
  - It is generally a good idea to apply liquid threadlock to all bolts.
  - Tighten included hardware to torque specifications in bottom table unless it is otherwise specified, factory bolts should be torqued to factory Jeep specifications.
- 





**After alignment is complete and no additional adjustments are to be made to control arms. Torque all 1" Jam Nuts to 250 ft/lbs and all 1-1/4" Jam Nuts torque to 300 ft/lbs. Regularly check all jam nuts and punch bolts on all control arms for proper torque/tightness. Failure to do so may cause premature wear of threads on arms.**

## **INSTALL:**

1. With vehicle in park, on flat ground and emergency brake applied, remove the bolts on both ends of factory trackbar.
  2. Once factory trackbar has been removed, bolt new EVO MFG trackbar on **ONLY TO THE FRAME SIDE**.
  3. The trackbar will need to be guided into the bracket at the axle. For the front trackbars turn the steering wheel until trackbar bolts line up.
  4. Once trackbar lines up with hole in trackbar bracket on the axle side, insert factory bolt and loosely tighten bolt. Tighten bolts to specified torque.
- 





After Install:

- Tighten all bolts securing purchased parts to specified locations.
- After completing installation using provided instructions, go through all steps again to make sure nothing was missed, not tightened or improperly assembled.
- Some components may need to be purchased separately.
- Check turn signals, headlights, fog lights (if applicable), taillights, blinkers and windshield wipers.
- Adjust mirrors, speedometer and headlights if needed.
- Make sure all gauges are fully operational.
- Drive the vehicle slowly for a couple minutes, looking and listening for abnormal noises while driving. After modification of a vehicle there will be differences in driving experiences and capabilities, be mindful of that.
- Inspect and Retorque all Bolts after 500 miles of completed installation and regularly thereafter.
- Some modification may be required.

Recommended Torque:

Size	Grade 2		Grade 5		Grade 8		18-8 S/S	
	Coarse	Fine	Coarse	Fine	Coarse	Fine	Coarse	Fine
<b>#4*</b>	-	-	-	-	-	-	5.2	-
<b>#6*</b>	-	-	-	-	-	-	9.6	-
<b>#8*</b>	-	-	-	-	-	-	19.8	-
<b>#10*</b>	-	-	-	-	-	-	22.8	31.7
<b>1/4</b>	4	4.7	6.3	7.3	9	10	6.3	7.8
<b>5/16</b>	8	9	13	14	18	20	11	11.8
<b>3/8</b>	15	17	23	26	33	37	20	22
<b>7/16</b>	24	27	37	41	52	58	31	33
<b>1/2</b>	37	41	57	64	80	90	43	45
<b>9/16</b>	53	59	82	91	115	129	57	63
<b>5/8</b>	73	83	112	128	159	180	93	104
<b>3/4</b>	125	138	200	223	282	315	128	124
<b>7/8</b>	129	144	322	355	454	501	194	193
<b>1†</b>	188	210	483	541	682	764	287	289



EVO Manufacturing  
Jeep Wrangler JL/JT Gladiator  
JL/JT Trackbars  
EVO- 3047B, 3048B, 3049B

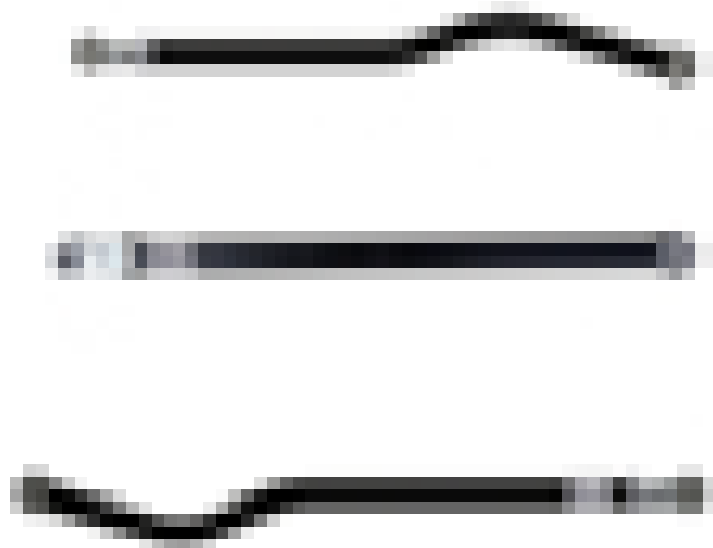



Before starting installation procedure please read <http://evomfg.com>Returns-Warranties-Shipping>

**CAREFULLY READ AND FOLLOW ALL INSTRUCTIONS IN THIS MANUAL AND KEEP FOR FUTURE REFERENCE. IF YOU HAVE ANY QUESTIONS ABOUT THE PRODUCT CALL EVO MANUFACTURING. FAILURE TO FOLLOW GUIDELINES COULD RESULT IN MALFUNCTION OF PARTS OR INJURY. PLEASE HAVE A TRAINED PROFESSIONAL ASSIST WITH OR INSTALL ALL PRODUCTS. INSTALLING EVO MFG PRODUCTS OR KITS DEMANDS SPECIFIC KNOWLEDGE, TOOLS AND EXPERIENCE. GENERAL KNOWLEDGE OF HOW TO USE LATER SPECIFIED TOOLS AND/OR LIMITED EXPERIENCE WITH EVO MFG PRODUCTS MAY NOT BE ENOUGH TO PROPERLY COMPLETE THESE TASKS. SOME OF EVO MFG PRODUCTS MAY REQUIRE TWO OR MORE PEOPLE TO INSTALL SAFELY AND CORRECTLY. DO NOT ATTEMPT ALONE, ALWAYS ENLIST THE HELP OF TRAINED PROFESSIONAL WHEN NEEDED.**

**Notes: Set Up Before installation**

**This is a general instruction for this component kit.**

**Directions/pictures may vary for each specific install, use for reference only.**

**Keep all mounting bolts loose (installed but not torqued) we will torque later at the end of complete installation**

**STARTING LENGTH FOR JL/JT FRONT TRACK BAR CENTER TO CENTER, 34 1/4"**

**STARTING LENGTH FOR JL REAR TRACKBAR CENTER TO CENTER, 37 7/16"**

**STARTING LENGTH FOR JT REAR TRACKBAR CENTER TO CENTER, 33 9/16"**

**READ BEFORE INSTALL:**

ALL measurements stated above are starting points only, every vehicle is different. Professional alignment is recommended.

It is generally a good idea to apply Loctite to all threaded bolts.

ALWAYS wear safety glasses and other approved safety gear when working on a vehicle.

All supplied bolts torqued according to chart at end of instruction.

It is recommended all installation be performed by a trained professional. Some modification may have to be done.

Paint all unfinished surfaces after install is complete.



Parts included: Table below shows JL/JT Trackbars.

Description	#	Part #	Quantity
JL/JT Front Trackbar	1	3047B	1
JT Rear Trackbar	2	3049B	1
JL Rear Trackbar	3	3048B	1



**Note:** For JL/JT FRONT and JT REAR trackbars, adjustable end attaches at AXLE side. For JL REAR adjustable end goes to FRAME side.





**Recommended Tools:**

- Standard socket set w/ wrench
  - OR Standard wrench set
- 



**Safety Steps for installation**

- For installing EVO MFG products always use wheel chokes to block rear tires from rolling.
  - Always make sure you have everything necessary ready before install.
  - If you have to, carefully lift front of vehicle by front frame rails extending suspension until tires leave the ground, place frame on approved jack stands for vehicle. Verify all lines/wires are not over extended.
  - Remove tires if needed for easier install.
  - Make sure to wear safety equipment (eye protection, hand protection, foot protection etc.) at all times during installation.
  - Make sure all safety precautions have been taken.
  - Always check and replace any part of vehicle that is worn or broken before starting install.
  - Do not mix anything EVO with weaker alternatives.
  - It is generally a good idea to apply liquid threadlock to all bolts.
  - Tighten included hardware to torque specifications in bottom table unless it is otherwise specified, factory bolts should be torqued to factory Jeep specifications.
- 





**After alignment is complete and no additional adjustments are to be made to control arms. Torque all 1" Jam Nuts to 250 ft/lbs and all 1-1/4" Jam Nuts torque to 300 ft/lbs. Regularly check all jam nuts and punch bolts on all control arms for proper torque/tightness. Failure to do so may cause premature wear of threads on arms.**

### **Front INSTALL:**

1. With vehicle in park, on flat ground and emergency brake applied, remove the bolts on both ends of factory trackbar.
  2. Clearance Front Trackbar Frame Pocket as Shown. Paint exposed metal before installing new bar.
  3. Once factory trackbar has been removed, bolt new EVO MFG trackbar on **ONLY TO THE FRAME SIDE**.
  4. The trackbar will need to be guided into the bracket at the axle. For the front trackbars turn the steering wheel until trackbar bolts line up.
  5. Once trackbar lines up with hole in trackbar bracket on the axle side, insert factory bolt and loosely tighten bolt. Tighten bolts to specified torque.
- 





After Install:

- Tighten all bolts securing purchased parts to specified locations.
- After completing installation using provided instructions, go through all steps again to make sure nothing was missed, not tightened or improperly assembled.
- Some components may need to be purchased separately.
- Check turn signals, headlights, fog lights (if applicable), taillights, blinkers and windshield wipers.
- Adjust mirrors, speedometer and headlights if needed.
- Make sure all gauges are fully operational.
- Drive the vehicle slowly for a couple minutes, looking and listening for abnormal noises while driving. After modification of a vehicle there will be differences in driving experiences and capabilities, be mindful of that.
- Inspect and Retorque all Bolts after 500 miles of completed installation and regularly thereafter.
- Some modification may be required.

Recommended Torque:

Size	Grade 2		Grade 5		Grade 8		18-8 S/S	
	Coarse	Fine	Coarse	Fine	Coarse	Fine	Coarse	Fine
<b>#4*</b>	-	-	-	-	-	-	5.2	-
<b>#6*</b>	-	-	-	-	-	-	9.6	-
<b>#8*</b>	-	-	-	-	-	-	19.8	-
<b>#10*</b>	-	-	-	-	-	-	22.8	31.7
<b>1/4</b>	4	4.7	6.3	7.3	9	10	6.3	7.8
<b>5/16</b>	8	9	13	14	18	20	11	11.8
<b>3/8</b>	15	17	23	26	33	37	20	22
<b>7/16</b>	24	27	37	41	52	58	31	33
<b>1/2</b>	37	41	57	64	80	90	43	45
<b>9/16</b>	53	59	82	91	115	129	57	63
<b>5/8</b>	73	83	112	128	159	180	93	104
<b>3/4</b>	125	138	200	223	282	315	128	124
<b>7/8</b>	129	144	322	355	454	501	194	193
<b>1†</b>	188	210	483	541	682	764	287	289



EVO Manufacturing  
Jeep Wrangler JL/JT Gladiator  
JL/JT Trackbars  
EVO- 3047B, 3048B, 3049B





Before starting installation procedure please read <http://evomfg.com>Returns-Warranties-Shipping>

**CAREFULLY READ AND FOLLOW ALL INSTRUCTIONS IN THIS MANUAL AND KEEP FOR FUTURE REFERENCE. IF YOU HAVE ANY QUESTIONS ABOUT THE PRODUCT CALL EVO MANUFACTURING. FAILURE TO FOLLOW GUIDELINES COULD RESULT IN MALFUNCTION OF PARTS OR INJURY. PLEASE HAVE A TRAINED PROFESSIONAL ASSIST WITH OR INSTALL ALL PRODUCTS. INSTALLING EVO MFG PRODUCTS OR KITS DEMANDS SPECIFIC KNOWLEDGE, TOOLS AND EXPERIENCE. GENERAL KNOWLEDGE OF HOW TO USE LATER SPECIFIED TOOLS AND/OR LIMITED EXPERIENCE WITH EVO MFG PRODUCTS MAY NOT BE ENOUGH TO PROPERLY COMPLETE THESE TASKS. SOME OF EVO MFG PRODUCTS MAY REQUIRE TWO OR MORE PEOPLE TO INSTALL SAFELY AND CORRECTLY. DO NOT ATTEMPT ALONE, ALWAYS ENLIST THE HELP OF TRAINED PROFESSIONAL WHEN NEEDED.**

**Notes: Set Up Before installation**

**This is a general instruction for this component kit.**

**Directions/pictures may vary for each specific install, use for reference only.**

**Keep all mounting bolts loose (installed but not torqued) we will torque later at the end of complete installation**

**STARTING LENGTH FOR JL/JT FRONT TRACK BAR CENTER TO CENTER, 34 1/4"**

**STARTING LENGTH FOR JL REAR TRACKBAR CENTER TO CENTER, 37 7/16"**

**STARTING LENGTH FOR JT REAR TRACKBAR CENTER TO CENTER, 33 9/16"**

**READ BEFORE INSTALL:**

ALL measurements stated above are starting points only, every vehicle is different. Professional alignment is recommended.

It is generally a good idea to apply Loctite to all threaded bolts.

ALWAYS wear safety glasses and other approved safety gear when working on a vehicle.

All supplied bolts torqued according to chart at end of instruction.

It is recommended all installation be performed by a trained professional. Some modification may have to be done.

Paint all unfinished surfaces after install is complete.



Parts included: Table below shows JL/JT Trackbars.

Description	#	Part #	Quantity
JL/JT Front Trackbar	1	3047B	1
JT Rear Trackbar	2	3049B	1
JL Rear Trackbar	3	3048B	1



**Note:** For JL/JT FRONT and JT REAR trackbars, adjustable end attaches at AXLE side. For JL REAR adjustable end goes to FRAME side.



#### **Recommended Tools:**

- Standard socket set w/ wrench
  - OR Standard wrench set
- 



#### **Safety Steps for installation**

- For installing EVO MFG products always use wheel chokes to block rear tires from rolling.
  - Always make sure you have everything necessary ready before install.
  - If you have to, carefully lift front of vehicle by front frame rails extending suspension until tires leave the ground, place frame on approved jack stands for vehicle. Verify all lines/wires are not over extended.
  - Remove tires if needed for easier install.
  - Make sure to wear safety equipment (eye protection, hand protection, foot protection etc.) at all times during installation.
  - Make sure all safety precautions have been taken.
  - Always check and replace any part of vehicle that is worn or broken before starting install.
  - Do not mix anything EVO with weaker alternatives.
  - It is generally a good idea to apply liquid threadlock to all bolts.
  - Tighten included hardware to torque specifications in bottom table unless it is otherwise specified, factory bolts should be torqued to factory Jeep specifications.
- 





**After alignment is complete and no additional adjustments are to be made to control arms. Torque all 1" Jam Nuts to 250 ft/lbs and all 1-1/4" Jam Nuts torque to 300 ft/lbs. Regularly check all jam nuts and punch bolts on all control arms for proper torque/tightness. Failure to do so may cause premature wear of threads on arms.**

## **INSTALL:**

1. With vehicle in park, on flat ground and emergency brake applied, remove the bolts on both ends of factory trackbar.
  2. Once factory trackbar has been removed, bolt new EVO MFG trackbar on **ONLY TO THE FRAME SIDE**.
  3. The trackbar will need to be guided into the bracket at the axle. For the front trackbars turn the steering wheel until trackbar bolts line up.
  4. Once trackbar lines up with hole in trackbar bracket on the axle side, insert factory bolt and loosely tighten bolt. Tighten bolts to specified torque.
- 







After Install:

- Tighten all bolts securing purchased parts to specified locations.
- After completing installation using provided instructions, go through all steps again to make sure nothing was missed, not tightened or improperly assembled.
- Some components may need to be purchased separately.
- Check turn signals, headlights, fog lights (if applicable), taillights, blinkers and windshield wipers.
- Adjust mirrors, speedometer and headlights if needed.
- Make sure all gauges are fully operational.
- Drive the vehicle slowly for a couple minutes, looking and listening for abnormal noises while driving. After modification of a vehicle there will be differences in driving experiences and capabilities, be mindful of that.
- Inspect and Retorque all Bolts after 500 miles of completed installation and regularly thereafter.
- Some modification may be required.

Recommended Torque:

Size	Grade 2		Grade 5		Grade 8		18-8 S/S	
	Coarse	Fine	Coarse	Fine	Coarse	Fine	Coarse	Fine
<b>#4*</b>	-	-	-	-	-	-	5.2	-
<b>#6*</b>	-	-	-	-	-	-	9.6	-
<b>#8*</b>	-	-	-	-	-	-	19.8	-
<b>#10*</b>	-	-	-	-	-	-	22.8	31.7
<b>1/4</b>	4	4.7	6.3	7.3	9	10	6.3	7.8
<b>5/16</b>	8	9	13	14	18	20	11	11.8
<b>3/8</b>	15	17	23	26	33	37	20	22
<b>7/16</b>	24	27	37	41	52	58	31	33
<b>1/2</b>	37	41	57	64	80	90	43	45
<b>9/16</b>	53	59	82	91	115	129	57	63
<b>5/8</b>	73	83	112	128	159	180	93	104
<b>3/4</b>	125	138	200	223	282	315	128	124
<b>7/8</b>	129	144	322	355	454	501	194	193
<b>1†</b>	188	210	483	541	682	764	287	289



EVO Manufacturing  
Jeep Wrangler JL/JT Gladiator  
JL/JT Trackbars  
EVO- 3047B, 3048B, 3049B





Before starting installation procedure please read <http://evomfg.com>Returns-Warranties-Shipping>

**CAREFULLY READ AND FOLLOW ALL INSTRUCTIONS IN THIS MANUAL AND KEEP FOR FUTURE REFERENCE. IF YOU HAVE ANY QUESTIONS ABOUT THE PRODUCT CALL EVO MANUFACTURING. FAILURE TO FOLLOW GUIDELINES COULD RESULT IN MALFUNCTION OF PARTS OR INJURY. PLEASE HAVE A TRAINED PROFESSIONAL ASSIST WITH OR INSTALL ALL PRODUCTS. INSTALLING EVO MFG PRODUCTS OR KITS DEMANDS SPECIFIC KNOWLEDGE, TOOLS AND EXPERIENCE. GENERAL KNOWLEDGE OF HOW TO USE LATER SPECIFIED TOOLS AND/OR LIMITED EXPERIENCE WITH EVO MFG PRODUCTS MAY NOT BE ENOUGH TO PROPERLY COMPLETE THESE TASKS. SOME OF EVO MFG PRODUCTS MAY REQUIRE TWO OR MORE PEOPLE TO INSTALL SAFELY AND CORRECTLY. DO NOT ATTEMPT ALONE, ALWAYS ENLIST THE HELP OF TRAINED PROFESSIONAL WHEN NEEDED.**

**Notes: Set Up Before installation**

**This is a general instruction for this component kit.**

**Directions/pictures may vary for each specific install, use for reference only.**

**Keep all mounting bolts loose (installed but not torqued) we will torque later at the end of complete installation**

**STARTING LENGTH FOR JL/JT FRONT TRACK BAR CENTER TO CENTER, 34 1/4"**

**STARTING LENGTH FOR JL REAR TRACKBAR CENTER TO CENTER, 37 7/16"**

**STARTING LENGTH FOR JT REAR TRACKBAR CENTER TO CENTER, 33 9/16"**

**READ BEFORE INSTALL:**

ALL measurements stated above are starting points only, every vehicle is different. Professional alignment is recommended.

It is generally a good idea to apply Loctite to all threaded bolts.

ALWAYS wear safety glasses and other approved safety gear when working on a vehicle.

All supplied bolts torqued according to chart at end of instruction.

It is recommended all installation be performed by a trained professional. Some modification may have to be done.

Paint all unfinished surfaces after install is complete.



Parts included: Table below shows JL/JT Trackbars.

Description	#	Part #	Quantity
JL/JT Front Trackbar	1	3047B	1
JT Rear Trackbar	2	3049B	1
JL Rear Trackbar	3	3048B	1



**Note:** For JL/JT FRONT and JT REAR trackbars, adjustable end attaches at AXLE side. For JL REAR adjustable end goes to FRAME side.



#### **Recommended Tools:**

- Standard socket set w/ wrench
  - OR Standard wrench set
- 



#### **Safety Steps for installation**

- For installing EVO MFG products always use wheel chokes to block rear tires from rolling.
  - Always make sure you have everything necessary ready before install.
  - If you have to, carefully lift front of vehicle by front frame rails extending suspension until tires leave the ground, place frame on approved jack stands for vehicle. Verify all lines/wires are not over extended.
  - Remove tires if needed for easier install.
  - Make sure to wear safety equipment (eye protection, hand protection, foot protection etc.) at all times during installation.
  - Make sure all safety precautions have been taken.
  - Always check and replace any part of vehicle that is worn or broken before starting install.
  - Do not mix anything EVO with weaker alternatives.
  - It is generally a good idea to apply liquid threadlock to all bolts.
  - Tighten included hardware to torque specifications in bottom table unless it is otherwise specified, factory bolts should be torqued to factory Jeep specifications.
- 





**After alignment is complete and no additional adjustments are to be made to control arms. Torque all 1" Jam Nuts to 250 ft/lbs and all 1-1/4" Jam Nuts torque to 300 ft/lbs. Regularly check all jam nuts and punch bolts on all control arms for proper torque/tightness. Failure to do so may cause premature wear of threads on arms.**

## **INSTALL:**

1. With vehicle in park, on flat ground and emergency brake applied, remove the bolts on both ends of factory trackbar.
  2. Once factory trackbar has been removed, bolt new EVO MFG trackbar on **ONLY TO THE FRAME SIDE**.
  3. The trackbar will need to be guided into the bracket at the axle. For the front trackbars turn the steering wheel until trackbar bolts line up.
  4. Once trackbar lines up with hole in trackbar bracket on the axle side, insert factory bolt and loosely tighten bolt. Tighten bolts to specified torque.
- 





After Install:

- Tighten all bolts securing purchased parts to specified locations.
- After completing installation using provided instructions, go through all steps again to make sure nothing was missed, not tightened or improperly assembled.
- Some components may need to be purchased separately.
- Check turn signals, headlights, fog lights (if applicable), taillights, blinkers and windshield wipers.
- Adjust mirrors, speedometer and headlights if needed.
- Make sure all gauges are fully operational.
- Drive the vehicle slowly for a couple minutes, looking and listening for abnormal noises while driving. After modification of a vehicle there will be differences in driving experiences and capabilities, be mindful of that.
- Inspect and Retorque all Bolts after 500 miles of completed installation and regularly thereafter.
- Some modification may be required.

Recommended Torque:

Size	Grade 2		Grade 5		Grade 8		18-8 S/S	
	Coarse	Fine	Coarse	Fine	Coarse	Fine	Coarse	Fine
<b>#4*</b>	-	-	-	-	-	-	5.2	-
<b>#6*</b>	-	-	-	-	-	-	9.6	-
<b>#8*</b>	-	-	-	-	-	-	19.8	-
<b>#10*</b>	-	-	-	-	-	-	22.8	31.7
<b>1/4</b>	4	4.7	6.3	7.3	9	10	6.3	7.8
<b>5/16</b>	8	9	13	14	18	20	11	11.8
<b>3/8</b>	15	17	23	26	33	37	20	22
<b>7/16</b>	24	27	37	41	52	58	31	33
<b>1/2</b>	37	41	57	64	80	90	43	45
<b>9/16</b>	53	59	82	91	115	129	57	63
<b>5/8</b>	73	83	112	128	159	180	93	104
<b>3/4</b>	125	138	200	223	282	315	128	124
<b>7/8</b>	129	144	322	355	454	501	194	193
<b>1†</b>	188	210	483	541	682	764	287	289



EVO Manufacturing

Jeep Wrangler JL and JT Gladiator 2018+

JL/JT Axle End Forging C2 Gusset Kit

EVO-3050







Before starting installation procedure please read <http://evomfg.com>Returns-Warranties-Shipping>

**CAREFULLY READ AND FOLLOW ALL INSTRUCTIONS IN THIS MANUAL AND KEEP FOR FUTURE REFERENCE. IF YOU HAVE ANY QUESTIONS ABOUT THE PRODUCT CALL EVO MANUFACTURING. FAILURE TO FOLLOW GUIDELINES COULD RESULT IN MALFUNCTION OF PARTS OR INJURY. PLEASE HAVE A TRAINED PROFESSIONAL ASSIST WITH OR INSTALL ALL PRODUCTS. INSTALLING EVO MFG PRODUCTS OR KITS DEMANDS SPECIFIC KNOWLEDGE, TOOLS AND EXPERIENCE. GENERAL KNOWLEDGE OF HOW TO USE LATER SPECIFIED TOOLS AND/OR LIMITED EXPERIENCE WITH EVO MFG PRODUCTS MAY NOT BE ENOUGH TO PROPERLY COMPLETE THESE TASKS. SOME OF EVO MFG PRODUCTS MAY REQUIRE TWO OR MORE PEOPLE TO INSTALL SAFELY AND CORRECTLY. DO NOT ATTEMPT ALONE, ALWAYS ENLIST THE HELP OF TRAINED PROFESSIONAL WHEN NEEDED.**

**Notes: Set Up Before installation**

**Designed on Rubicon axles, Sport and Sahara mat need slight modification.**

**Recommended weld with axle suspended not under load of vehicle.**

**Some grinding may be required**

**Installer needs to do a full inspection for clearance on all surrounding components prior to welding**

**READ BEFORE INSTALL:**

**Gussets should be welded alternating sides from ends to middle.**

Make sure to clean axles as well as possible.

ALWAYS wear safety glasses and other approved safety gear when working on a vehicle.

Some grinding / sanding may be required to achieve your desired fitment.

It is recommended all installation be performed by a trained professional. Some modification may have to be done.

Recommended to remove tires and that ball joints are removed/ replaced (use Jeep ball joint puller)



Parts included: Table below shows Jeep JL/JT C2 Axle End Forging Gusset Set

Description	#	Part #	Quantity
C2 Axle End Forging Gusset Lower	1	EVO-12390	2
C2 Axle End Forging Gusset Upper Driver	2	EVO-12388	1
C2 Axle End Forging Gusset Upper Passenger	3	EVO-12389	1
Hex Head Drilling Screws	4	EVO-900438	2

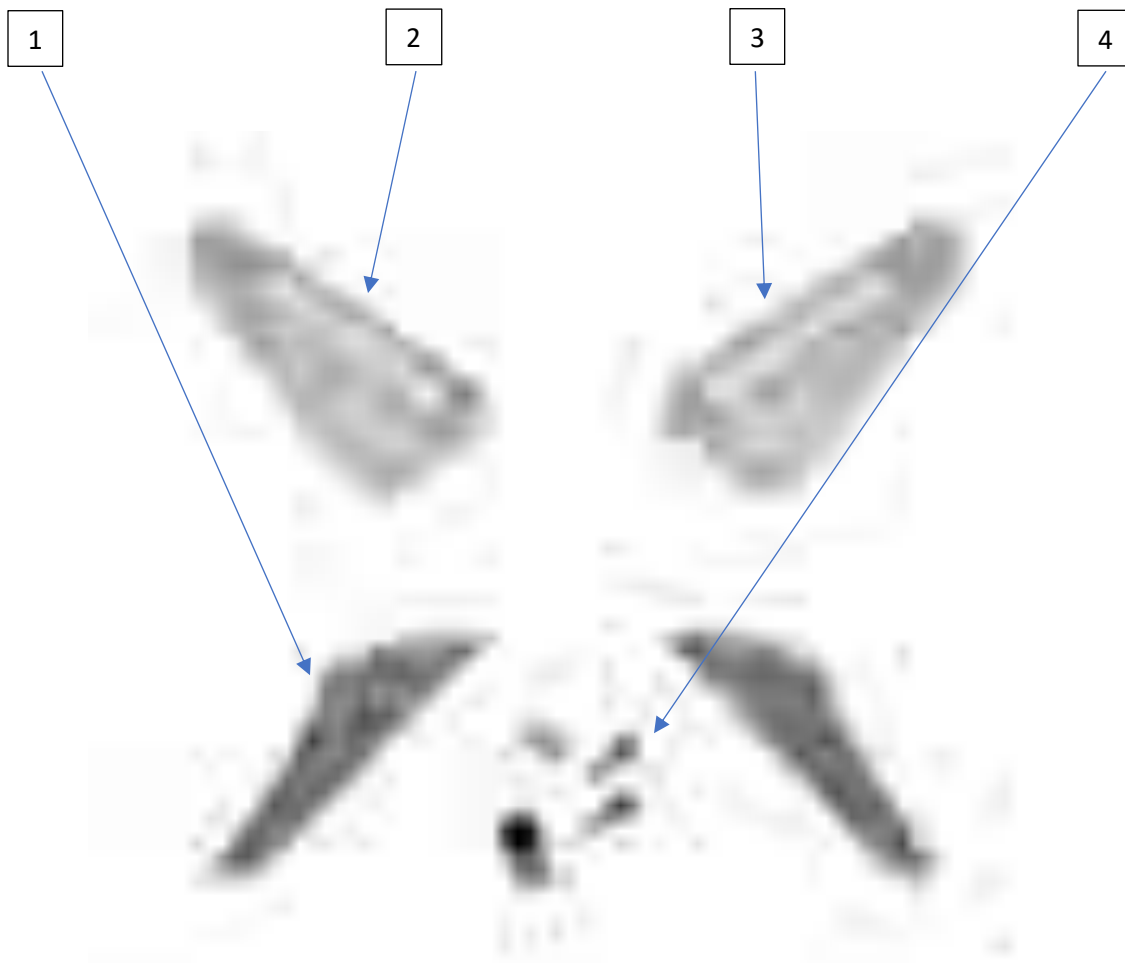



### Recommended Tools:

- Welder
- Welding Materials
- Welding Clamps
- Rubber Mallet
- Grinder
- Wrenches
- Welding helmet + safety equipment



### Safety Steps for installation

- For installing EVO MFG products always use wheel chokes to block rear tires from rolling.
- Always make sure you have everything necessary ready before install.
- If you have to, carefully lift front of vehicle by front frame rails extending suspension until tires leave the ground, place frame on approved jack stands for vehicle. Verify all lines/wires are not over extended.
- Remove tires if needed for easier install.
- Make sure to wear safety equipment (eye protection, hand protection, foot protection etc.) at all times during installation.
- Make sure all safety precautions have been taken.
- Always check and replace any part of vehicle that is worn or broken before starting install.
- Do not mix anything EVO with weaker alternatives.
- It is generally a good idea to apply liquid threadlock to all bolts.
- Tighten included hardware to torque specifications in bottom table unless it is otherwise specified, factory bolts should be torqued to factory Jeep specifications.
- Welding creates a very bright arc that should not be looked at without an approved protective shield/clothing. Welded surfaces and areas in their vicinity will be very hot for a long time. All welding should be performed by a professional. USE CAUTION





1. Using an impact or something similar, take the provided bolt and insert it into upper gusset, it is self tapping, make sure bolt is straight into hole and that it only inserted to seat flush with gusset bracket. **Do not strip hole/bolt by over tightening.**
- 



2. Using the picture as reference, use grinder with a cutting wheel to cut metal wire retainer for the brake line.
- 



3. Remove bolt holding metal brake line retaining wire and push out of the way.
- 





4. Prepare axles for welding by placing C2 Axle Gussets on top and bottom of driver side axle by hand. Mark axle with paint pen/marker where all surfaces are to be grinded/sanded to remove paint/surface contamination.

Grind/sand, repeat on other side.

**Do not grind deep into metal, just take off paint layer and any rust.**



5. Place Upper Gussets in place on both driver and passenger side. Make sure that C2's seat fully against spring perch. Tap with rubber mallet if required. Some grinding of bracket may be necessary to fit on axle.

Sahara and sport models will require grinding, start from coil side of bracket and remove material until preferred fitment. Make sure bracket does not contact coils.

Verify that all coating/paint is cleaned and acceptable fitment has been achieved from all areas to be welded. Tack in place in multiple areas top and bottom.





6. Place lower Axle C2's in place on driver side and verify all coating/paint is cleaned from all areas to be welded.  
Grind bracket to fit on axle if necessary.

Verify that all coating/paint is cleaned from all areas to be welded. Tack in place and repeat on other side.

---



7. Weld gussets in no more than 1 inch increments alternating from driver to passenger sides after every incremental weld. After welding one increment, let welded surface cool before alternating to the opposite side.

8. Insert brake line into retaining clip, put bolt through bolt holes in retaining clip and bolt into upper C2 bracket through hole.
- 



**Note:** Paint all exposed metal.



After Install:

- Tighten all bolts securing purchased parts to specified locations.
- After completing installation using provided instructions, go through all steps again to make sure nothing was missed, not tightened or improperly assembled.
- Some components may need to be purchased separately.
- Check turn signals, headlights, fog lights (if applicable), taillights, blinkers and windshield wipers.
- Adjust mirrors, speedometer and headlights if needed.
- Make sure all gauges are fully operational.
- Drive the vehicle slowly for a couple minutes, looking and listening for abnormal noises while driving. After modification of a vehicle there will be differences in driving experiences and capabilities, be mindful of that.
- Inspect and Retorque all Bolts after 500 miles of completed installation and regularly thereafter.
- Some modification may be required.

**Recommended Torque:**

Size	Grade 2		Grade 5		Grade 8		18-8 S/S	
	Coarse	Fine	Coarse	Fine	Coarse	Fine	Coarse	Fine
<b>#4*</b>	-	-	-	-	-	-	5.2	-
<b>#6*</b>	-	-	-	-	-	-	9.6	-
<b>#8*</b>	-	-	-	-	-	-	19.8	-
<b>#10*</b>	-	-	-	-	-	-	22.8	31.7
<b>1/4</b>	4	4.7	6.3	7.3	9	10	6.3	7.8
<b>5/16</b>	8	9	13	14	18	20	11	11.8
<b>3/8</b>	15	17	23	26	33	37	20	22
<b>7/16</b>	24	27	37	41	52	58	31	33
<b>1/2</b>	37	41	57	64	80	90	43	45
<b>9/16</b>	53	59	82	91	115	129	57	63
<b>5/8</b>	73	83	112	128	159	180	93	104
<b>3/4</b>	125	138	200	223	282	315	128	124
<b>7/8</b>	129	144	322	355	454	501	194	193
<b>1+</b>	188	210	483	541	682	764	287	289





EVO Manufacturing

Jeep Wrangler JL and JT Gladiator 2018+

JL/JT Axle Tube and Differential Truss Kit

EVO-3051





Before starting installation procedure please read <http://evomfg.com>Returns-Warranties-Shipping>

**CAREFULLY READ AND FOLLOW ALL INSTRUCTIONS IN THIS MANUAL AND KEEP FOR FUTURE REFERENCE. IF YOU HAVE ANY QUESTIONS ABOUT THE PRODUCT CALL EVO MANUFACTURING. FAILURE TO FOLLOW GUIDELINES COULD RESULT IN MALFUNCTION OF PARTS OR INJURY. PLEASE HAVE A TRAINED PROFESSIONAL ASSIST WITH OR INSTALL ALL PRODUCTS. INSTALLING EVO MFG PRODUCTS OR KITS DEMANDS SPECIFIC KNOWLEDGE, TOOLS AND EXPERIENCE. GENERAL KNOWLEDGE OF HOW TO USE LATER SPECIFIED TOOLS AND/OR LIMITED EXPERIENCE WITH EVO MFG PRODUCTS MAY NOT BE ENOUGH TO PROPERLY COMPLETE THESE TASKS. SOME OF EVO MFG PRODUCTS MAY REQUIRE TWO OR MORE PEOPLE TO INSTALL SAFELY AND CORRECTLY. DO NOT ATTEMPT ALONE, ALWAYS ENLIST THE HELP OF TRAINED PROFESSIONAL WHEN NEEDED.**

**Notes: Set Up Before installation**

**Recommended weld with axle suspended not under load of vehicle.**

**Only weld to cast if you are experienced in the process, welding to cast is not required.**

**Be sure that your axle is a JL Dana 44.**

**1-1/2 inch minimum bump stop extensions required for truss, 2" with bridge installation.**

**Installer do a full inspection for clearance on all surrounding components prior to welding.**

**READ BEFORE INSTALL:**

**Truss should be welded alternating sides from ends to middle. Not to be welded while under vehicle load and recommended to be welded while slightly preloaded/tensioned in opposite direction.**

Make sure to clean axles as well as possible.

ALWAYS wear safety glasses and other approved safety gear when working on a vehicle.

Some grinding / sanding may be required to achieve your desired fitment.

It is recommended all installation be performed by a trained professional. Some modification may have to be done.

Recommended to remove tires.



Parts included: Table below shows Jeep JL/JT D44 M210 Advantec Axle Truss Kit

Description	#	Part #	Quantity
Truss FAD Overlay Section	1	EVO-12385	1
Main Pass Truss Section	2	EVO-12384	1
Over Differential Truss	3	EVO-12387	1
Driver Truss Section	4	EVO-12386	1

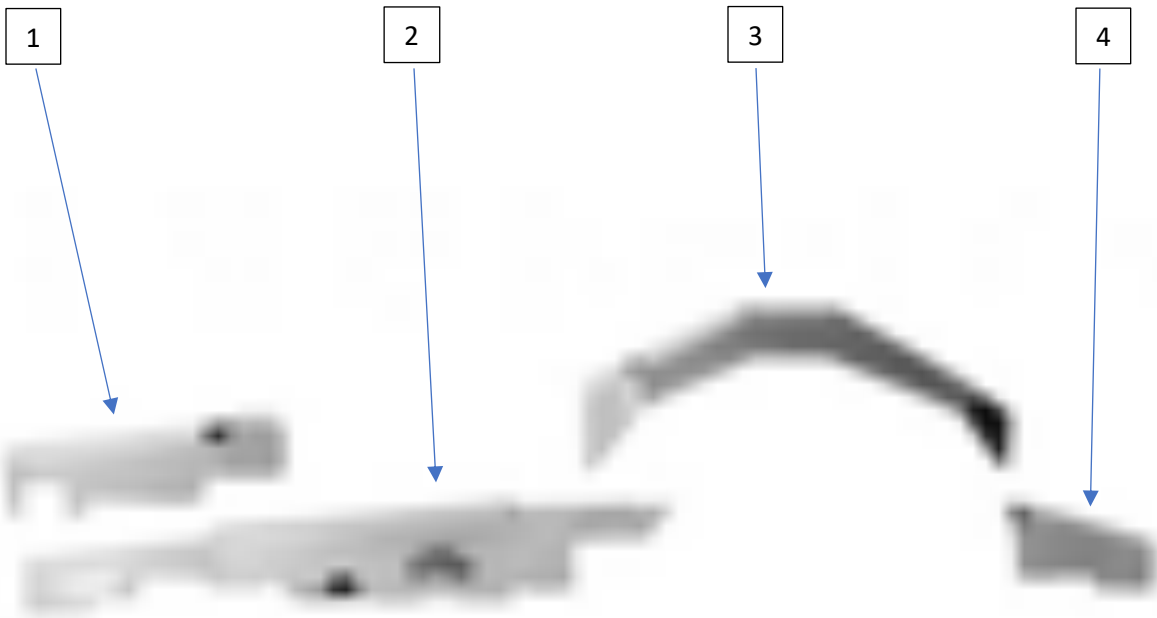



### Recommended Tools:

- Welder
  - Welding Materials
  - Welding Clamps
  - Rubber Mallet
  - Grinder
  - Standard Tool Set
- 



### Safety Steps for installation

- For installing EVO MFG products always use wheel chokes to block rear tires from rolling.
- Always make sure you have everything necessary ready before install.
- If you have to, carefully lift front of vehicle by front frame rails extending suspension until tires leave the ground, place frame on approved jack stands for vehicle. Verify all lines/wires are not over extended.
- Remove tires if needed for easier install.
- Make sure to wear safety equipment (eye protection, hand protection, foot protection etc.) at all times during installation.
- Make sure all safety precautions have been taken.
- Always check and replace any part of vehicle that is worn or broken before starting install.
- Do not mix anything EVO with weaker alternatives.
- It is generally a good idea to apply liquid threadlock to all bolts.
- Tighten included hardware to torque specifications in bottom table unless it is otherwise specified, factory bolts should be torqued to factory Jeep specifications.
- Welding creates a very bright arc that should not be looked at without an approved protective shield/clothing. Welded surfaces and areas in their vicinity will be very hot for a long time. All welding should be performed by a professional. USE CAUTION





## Install

1. Safely park vehicle on a flat surface, put in park and chalk tires.

Jack vehicle up using frame, take vehicle load off axle, use jack stands under axle for safety.

---





2. Prepare axles for welding by grinding or sanding on the upper half of the axle tubes and top of FAD (only grind the part that is cast into axle)
- 

**Do not grind deep into metal, just take off paint layer and any rust.**



3. Remove track bar from axle end of Jeep.





4. Place EVO Passenger side long and short truss sections on top of axle as shown in illustration. Ensure the trusses are seated to your axle. May have to grind truss edges to fit more precise.

**Wear proper safety equipment when grinding.**

---

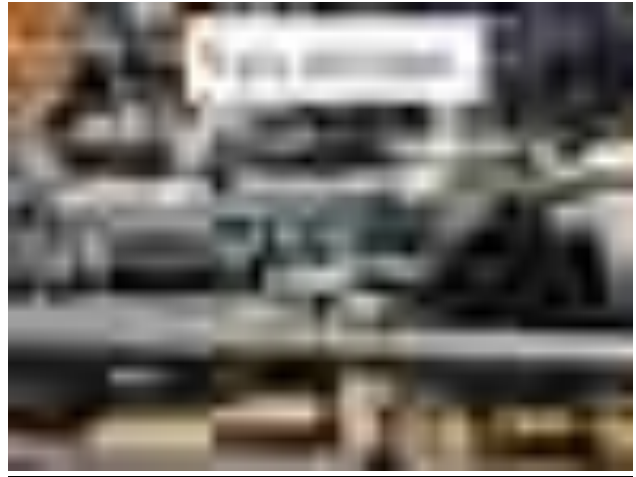

5. Ensure truss sections seat in place and adjust as needed. Some taps with a mallet may be necessary to align.
- 





6. Tack weld ends/corners to the axle in multiple locations at the ends of all brackets. Once you are satisfied with the fit, weld the EVO Short and Long passenger truss sections.

**Be sure to alternate weld segments from end to middle in 1-2 inch increments as picture specifies.**

**Note:** When welding, **do not** weld long sections in one weld. Alternate side to side, left to right, front to back, etc, until all weld sections are made.

---



7. Place EVO Bridge on axle as shown in illustration. Verify acceptable fitment and tack weld bridge to truss in multiple locations prior to fully welding.
8. Once tacked into place weld bridge to driver and passenger truss sections, then weld the upper pinch seams.

**Note:** When welding, **do not** weld long sections in one weld. Alternate side to side, left to right, front to back, etc, until all weld sections are made.

---







**Note:** Paint all exposed metal, reinstall trackbar and torque to factory specification

After Install:

- Tighten all bolts securing purchased parts to specified locations.
- After completing installation using provided instructions, go through all steps again to make sure nothing was missed, not tightened or improperly assembled.
- Some components may need to be purchased separately.
- Check turn signals, headlights, fog lights (if applicable), taillights, blinkers and windshield wipers.
- Adjust mirrors, speedometer and headlights if needed.
- Make sure all gauges are fully operational.
- Drive the vehicle slowly for a couple minutes, looking and listening for abnormal noises while driving. After modification of a vehicle there will be differences in driving experiences and capabilities, be mindful of that.
- Inspect and Retorque all Bolts after 500 miles of completed installation and regularly thereafter.
- Some modification may be required.

Recommended Torque:

Size	Grade 2		Grade 5		Grade 8		18-8 S/S	
	Coarse	Fine	Coarse	Fine	Coarse	Fine	Coarse	Fine
<b>#4*</b>	-	-	-	-	-	-	5.2	-
<b>#6*</b>	-	-	-	-	-	-	9.6	-
<b>#8*</b>	-	-	-	-	-	-	19.8	-
<b>#10*</b>	-	-	-	-	-	-	22.8	31.7
<b>1/4</b>	4	4.7	6.3	7.3	9	10	6.3	7.8
<b>5/16</b>	8	9	13	14	18	20	11	11.8
<b>3/8</b>	15	17	23	26	33	37	20	22
<b>7/16</b>	24	27	37	41	52	58	31	33
<b>1/2</b>	37	41	57	64	80	90	43	45
<b>9/16</b>	53	59	82	91	115	129	57	63
<b>5/8</b>	73	83	112	128	159	180	93	104
<b>3/4</b>	125	138	200	223	282	315	128	124
<b>7/8</b>	129	144	322	355	454	501	194	193
<b>1†</b>	188	210	483	541	682	764	287	289



EVO Manufacturing

Jeep Wrangler JK/JL and JT Gladiator

JK/JL/JT Quarter Pounder Front Bumper

EVO- 3057/B/AL



**Important:** Keep hardware pack containing jog plate and jog plate hardware.





Before starting installation procedure please read <http://evomfg.com>Returns-Warranties-Shipping>

**CAREFULLY READ AND FOLLOW ALL INSTRUCTIONS IN THIS MANUAL AND KEEP FOR FUTURE REFERENCE. IF YOU HAVE ANY QUESTIONS ABOUT THE PRODUCT CALL EVO MANUFACTURING. FAILURE TO FOLLOW GUIDELINES COULD RESULT IN MALFUNCTION OF PARTS OR INJURY. PLEASE HAVE A TRAINED PROFESSIONAL ASSIST WITH OR INSTALL ALL PRODUCTS. INSTALLING EVO MFG PRODUCTS OR KITS DEMANDS SPECIFIC KNOWLEDGE, TOOLS AND EXPERIENCE. GENERAL KNOWLEDGE OF HOW TO USE LATER SPECIFIED TOOLS AND/OR LIMITED EXPERIENCE WITH EVO MFG PRODUCTS MAY NOT BE ENOUGH TO PROPERLY COMPLETE THESE TASKS. SOME OF EVO MFG PRODUCTS MAY REQUIRE TWO OR MORE PEOPLE TO INSTALL SAFELY AND CORRECTLY. DO NOT ATTEMPT ALONE, ALWAYS ENLIST THE HELP OF TRAINED PROFESSIONAL WHEN NEEDED.**

**Notes: Set Up Before installation**

**Cutting and grinding will be necessary for this installation.**

**May need to use a second person to ease install.**

**Keep all mounting bolts loose (installed but not torqued) we will torque later at the end of complete installation**

**READ BEFORE INSTALL:**

It is generally a good idea to apply Loctite to all threaded bolts.

ALWAYS wear safety glasses and other approved safety gear when working on a vehicle.

All supplied bolts torqued according to chart at end of instruction.

It is recommended all installation be performed by a trained professional. Some modification may have to be done.

Paint all unfinished surfaces after install is complete.

On aluminum bumpers, heat should not be applied due to aluminum properties



Parts included: Table below shows EVO MFG Quarter Pounder Bumper.

Description	#	Part # B	Part # AL	Quantity
¼ Pounder Stubby Bumper	1	EVO-10038B	EVO-10038AL	1
Spacer Plate	2	EVO-10037B	EVO-10037AL	6
Hardware Pack	3	EVO-770014	EVO-770014	1
Jog Plate	4	EVO-12033B	EVO-10039AL	1
Jog Plate Hardware Pack	5	EVO-770045	EVO-770045	1

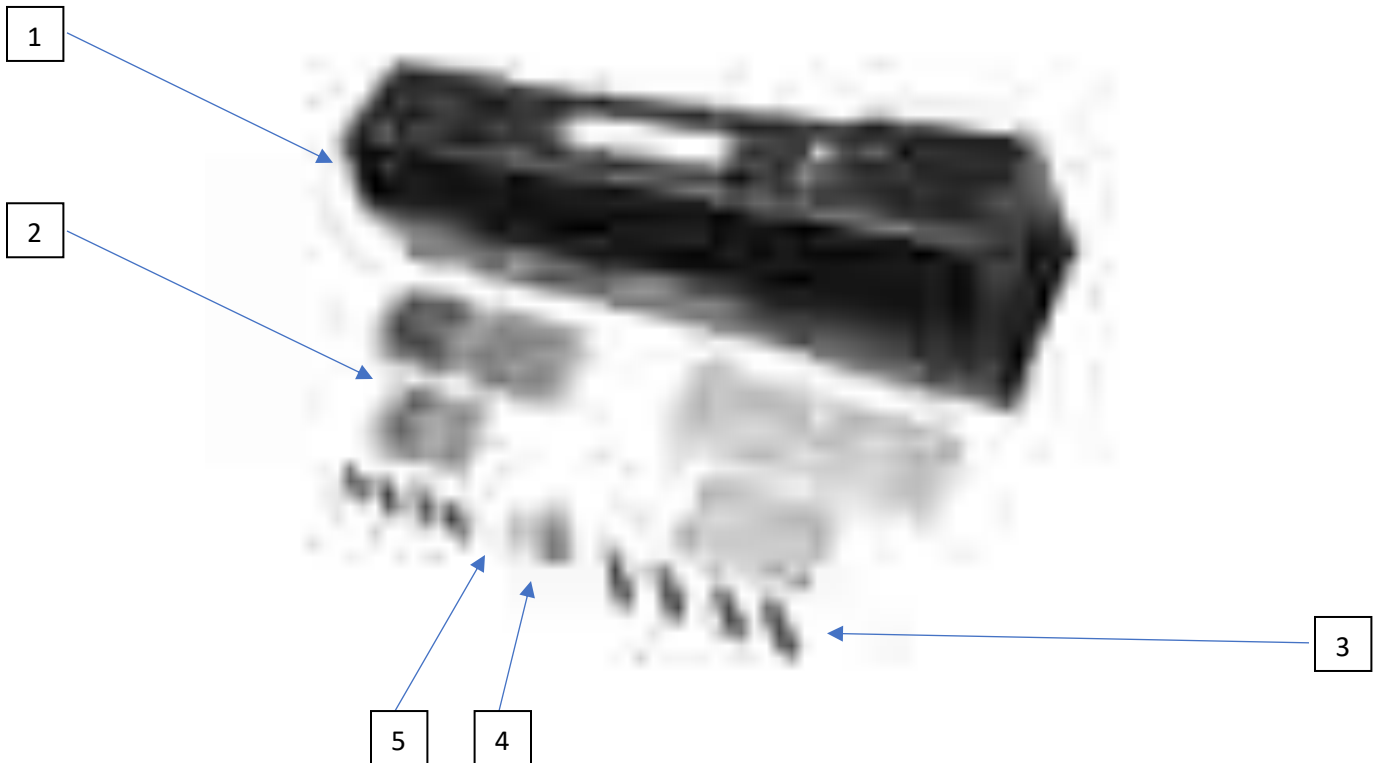

**Do not discard hardware pack containing jog plate and jog plate hardware. Critical for winch install.**



#### **Recommended Tools:**

- Allen set/ Driver Sockets
  - Impact with standard sockets
  - Sawzall/Cut off wheel or similar
  - Drill and ½" bit/ Step bit
- 



#### **Safety Steps for installation**

- For installing EVO MFG products always use wheel chokes to block rear tires from rolling.
  - Always make sure you have everything necessary ready before install.
  - If you have to, carefully lift front of vehicle by front frame rails extending suspension until tires leave the ground, place frame on approved jack stands for vehicle. Verify all lines/wires are not over extended.
  - Remove tires if needed for easier install.
  - Make sure to wear safety equipment (eye protection, hand protection, foot protection etc.) at all times during installation.
  - Make sure all safety precautions have been taken.
  - Always check and replace any part of vehicle that is worn or broken before starting install.
  - Do not mix anything EVO with weaker alternatives.
  - It is generally a good idea to apply liquid threadlock to all bolts.
  - Tighten included hardware to torque specifications in bottom table unless it is otherwise specified, factory bolts should be torqued to factory Jeep specifications.
- 





Various factory bumper options are available. Factory bumper removal steps therefore will vary. This is just a guide, follow factory manual if further instruction is required.

### **INSTALL:**

Safely park car on flat ground, put in park and chock wheels.

---

1. Remove factory front bumper by removing the 8 nuts on the inside of the bumper and remove the push clips on underside of bumper.
- 





2. Remove wires from fog lamps, remove bulbs (if applicable). Reference Jeep manual for removal of bulb, different year and models may vary.
- 



3. For JL and JTs remove the factory frame plates. This will not be reused.
- 



4. Remove upper factory plastic in front of grill. Start by removing plastic clips/screws then pull out plastic.
- 





5. Mark cut lines as shown. For the JK the cut line should be drawn right above crossmember on tabs that hold crossmember to frame bracket.
- 

JK cut line:



6. For the JL and JT the cut line should be drawn right above the bend in the frame bracket as shown.
- 

JL/JT cut line:







7. Using a Sawzall, cut off wheel or similar, remove/cut the lower front cross member using cut lines. Cut front and back of both sides on crossmember.

---

Use proper safety precautions and safety equipment. Make sure no wires are in the cutting path. Only cut specified area.

---



For installing winch:

If a winch is to be installed. Follow the directions that came with your winch and mount to the inner 4 bolt pattern on the inside of the ¼ Pounder. The EVO MFG Quarter Pounder bumper will accept center mount winches as well as offset winches.

---



For fairlead adjustment using the included EVO fairlead jog plate: Using jog plate hardware kit, mount jog plate to correct side of fairlead mount depending on type of winch. Put washer on bolt, then insert through bumper then jog plate, tighten nut onto backside of bolt.

Mount EVO Fairlead Jog Plate on passenger side for Offset Winch

---

Mount EVO Fairlead Jog Plate on driver side for Centered Winch

---





Verify that the supplied  $\frac{1}{2}$ " bolts will insert through all the 8 factory holes in your Jeeps frame. If not, drill the holes that do not fit with a  $\frac{1}{2}$ " drill.

8. Using the supplied hardware (2.0" without DRings, 2.5" with D-rings/Stinger all with washers) install through the upper right and left holes of both sides (4 Bolts total).

If you are using the EVO DRings/Stinger, these should be mounted at this time on the outer face of the bumper.

9. To space bumper forwards, on the inside face of the  $\frac{1}{4}$  Pounder, the Jeep JK will need two spacer plates per side on the inside mounting face of the bumper (in front of frame). For the Jeep JL and JT you will need three spacer plates.
10. Install  $\frac{1}{4}$  Pounder with spacer plates to factory frame.
11. Install supplied washers and nuts and 4 remaining lower bolts.
12. Torque all nuts to 80 lb/ft .





Optional Rubicon electronic sway bar mount relocation:

13. Remove bolt from the front mount of the swaybar motor. (long bolt that goes through the rubber isolator)

14. The motor will now freely rotate on the axis of the swaybar.

15. Rotate the swaybar motor rearward as much as possible.

---



16. With a 1/2" diameter drill mark off 1/2" from tip down on the drill with tape.

17. You may need to loosen the two bolts on the passenger side frame rail that holds the swaybar to the frame to get your drill to drill straight into the new mounting hole.

---



18. In the new mounting hole, drill from the passenger side toward the center of the vehicle 1/2" deep (up to tape mark) into new mounting hole. DO NOT DRILL MORE THAN 1/2".

19. Using the same bolt removed earlier install through the factory rubber isolator and into the newly drilled hole.

---





After Install:

- Tighten all bolts securing purchased parts to specified locations.
- After completing installation using provided instructions, go through all steps again to make sure nothing was missed, not tightened or improperly assembled.
- Some components may need to be purchased separately.
- Check turn signals, headlights, fog lights (if applicable), taillights, blinkers and windshield wipers.
- Adjust mirrors, speedometer and headlights if needed.
- Make sure all gauges are fully operational.
- Drive the vehicle slowly for a couple minutes, looking and listening for abnormal noises while driving. After modification of a vehicle there will be differences in driving experiences and capabilities, be mindful of that.
- Inspect and Retorque all Bolts after 500 miles of completed installation and regularly thereafter.
- Some modification may be required.

Recommended Torque:

Size	Grade 2		Grade 5		Grade 8		18-8 S/S	
	Coarse	Fine	Coarse	Fine	Coarse	Fine	Coarse	Fine
<b>#4*</b>	-	-	-	-	-	-	5.2	-
<b>#6*</b>	-	-	-	-	-	-	9.6	-
<b>#8*</b>	-	-	-	-	-	-	19.8	-
<b>#10*</b>	-	-	-	-	-	-	22.8	31.7
<b>1/4</b>	4	4.7	6.3	7.3	9	10	6.3	7.8
<b>5/16</b>	8	9	13	14	18	20	11	11.8
<b>3/8</b>	15	17	23	26	33	37	20	22
<b>7/16</b>	24	27	37	41	52	58	31	33
<b>1/2</b>	37	41	57	64	80	90	43	45
<b>9/16</b>	53	59	82	91	115	129	57	63
<b>5/8</b>	73	83	112	128	159	180	93	104
<b>3/4</b>	125	138	200	223	282	315	128	124
<b>7/8</b>	129	144	322	355	454	501	194	193
<b>1†</b>	188	210	483	541	682	764	287	289



EVO Manufacturing

Jeep Wrangler JK/JL and JT Gladiator

JK/JL/JT Quarter Pounder Aluminum Front Bumper

EVO- 3057AL





**Important:** Keep hardware pack containing jog plate and jog plate hardware.

Before starting installation procedure please read  
<http://evomfg.com>Returns-Warranties-Shipping>



**CAREFULLY READ AND FOLLOW ALL INSTRUCTIONS IN THIS MANUAL AND KEEP FOR FUTURE REFERENCE. IF YOU HAVE ANY QUESTIONS ABOUT THE PRODUCT CALL EVO MANUFACTURING. FAILURE TO FOLLOW GUIDELINES COULD RESULT IN MALFUNCTION OF PARTS OR INJURY. PLEASE HAVE A TRAINED PROFESSIONAL ASSIST WITH OR INSTALL ALL PRODUCTS. INSTALLING EVO MFG PRODUCTS OR KITS DEMANDS SPECIFIC KNOWLEDGE, TOOLS AND EXPERIENCE. GENERAL KNOWLEDGE OF HOW TO USE LATER SPECIFIED TOOLS AND/OR LIMITED EXPERIENCE WITH EVO MFG PRODUCTS MAY NOT BE ENOUGH TO PROPERLY COMPLETE THESE TASKS. SOME OF EVO MFG PRODUCTS MAY REQUIRE TWO OR MORE PEOPLE TO INSTALL SAFELY AND CORRECTLY. DO NOT ATTEMPT ALONE, ALWAYS ENLIST THE HELP OF TRAINED PROFESSIONAL WHEN NEEDED.**

**Notes: Set Up Before installation**

**Cutting and grinding will be necessary for this installation.**

**May need to use a second person to ease install.**

**Keep all mounting bolts loose (installed but not torqued) we will torque later at the end of complete installation**

**READ BEFORE INSTALL:**

It is generally a good idea to apply Loctite to all threaded bolts.

ALWAYS wear safety glasses and other approved safety gear when working on a vehicle.

All supplied bolts torqued according to chart at end of instruction.

It is recommended all installation be performed by a trained professional. Some modification may have to be done.

Paint all unfinished surfaces after install is complete.

On aluminum bumpers, heat should not be applied due to aluminum properties



Parts included: Table below shows EVO MFG Quarter Pounder Bumper.

Description	Part # AL	Quantity
¼ Pounder Stubby Bumper Alum	EVO-10038AL	1
Spacer Plate	EVO-10037AL	6
Hardware Pack	EVO-770014or15	1
Jog Plate	EVO-10039AL	1
Jog Plate Hardware Pack	EVO-770045	1
Winch Plate	EVO-12508	1
Winch Side Plate Right	EVO-12509	1
Winch Side Plate Left	EVO-12510	1
Winch Plate Tie In	EVO-12561	2
3/8" Hardware Pack		1
JK Winch Plate Nut Tabs	EVO-12075	2

Do not discard hardware pack containing jog plate and jog plate hardware. Critical for winch install.



#### **Recommended Tools:**

- Allen set/ Driver Sockets
  - Impact with standard sockets
  - Sawzall/Cut off wheel or similar
  - Drill and 9/16" bit/ Step bit
- 



#### **Safety Steps for installation**

- For installing EVO MFG products always use wheel chokes to block rear tires from rolling.
  - Always make sure you have everything necessary ready before install.
  - If you have to, carefully lift front of vehicle by front frame rails extending suspension until tires leave the ground, place frame on approved jack stands for vehicle. Verify all lines/wires are not over extended.
  - Remove tires if needed for easier install.
  - Make sure to wear safety equipment (eye protection, hand protection, foot protection etc.) at all times during installation.
  - Make sure all safety precautions have been taken.
  - Always check and replace any part of vehicle that is worn or broken before starting install.
  - Do not mix anything EVO with weaker alternatives.
  - It is generally a good idea to apply liquid threadlock to all bolts.
  - Tighten included hardware to torque specifications in bottom table unless it is otherwise specified, factory bolts should be torqued to factory Jeep specifications.
- 







Various factory bumper options are available. Factory bumper removal steps therefore will vary. This is just a guide, follow factory manual if further instruction is required.

### **INSTALL:**

Safely park car on flat ground, put in park and chock wheels.

---

1. Remove factory front bumper by removing the 8 nuts on the inside of the bumper and remove the push clips on underside of bumper.
- 





2. Remove wires from fog lamps, remove bulbs (if applicable). Reference Jeep manual for removal of bulb, different year and models may vary.
- 



3. For JL and JTs remove the factory frame plates. This will not be reused.
- 



4. Remove upper factory plastic in front of grill. Start by removing plastic clips/screws then pull out plastic.
- 





5. Mark cut lines as shown. For the JK the cut line should be drawn right above crossmember on tabs that hold crossmember to frame bracket.
- 

JK cut line:



6. For the JL and JT the cut line should be drawn right above the bend in the frame bracket as shown.
- 

JL/JT cut line:





7. Using a Sawzall, cut off wheel or similar, remove/cut the lower front cross member using cut lines. Cut front and back of both sides on crossmember.

---

Use proper safety precautions and safety equipment. Make sure no wires are in the cutting path. Only cut specified area.

---



For fairlead adjustment using the included EVO fairlead jog plate: Using jog plate hardware kit, mount jog plate to correct side of fairlead mount depending on type of winch. Put washer on bolt, then insert through bumper then jog plate, tighten nut onto backside of bolt.

Mount EVO Fairlead Jog Plate on passenger side for Offset Winch

---

Mount EVO Fairlead Jog Plate on driver side for Centered Winch

---





Loosely Install inner winch plate and left and right side plates.

JL/JT: Install winch side plates at this time with factory bolt into side of frame on each side and supplied 3/8" bolts in forward holes. Rear/grill side holes do not install at this time.

JK: Install side plates using supplied nut plates down inserted down into frame pocket and thread supplied bolts.





Using a drill and 9/16" of Step Drill Bit, Enlarge all 8 frame holes for ease of install.



8. Partially Pre-assemble bumper on table using 4 of the 1/2" socket head cap bolts (2 on each side). If installing Dring, Hoop or Stinger this should be staked aswell.

3 Spacer plates and outer winch spacer. Each side. As shown.





9. Lift Bumper assembly to vehicle and loosely install. This may require 2 or more people.

10. Install remaining ½" hardware.

Depending on winch choice/size, the inner ½" main bolts near winch may need to be shortend. Do so if needed.

11. On rear side from underneath. Install the winch plate to bumper tie in plates. These install under the winch plate and above the aluminum bumper. Connecting winch plate to bumper on the underside. Use the supplied 3/8" hardware. Upper bolts will install through winch side plates (rear hole), through winch plate and winch plate tie in. Lower bolt through bumper and winch tie in. Both sides.



---

**Torque all bolts per chart below.**

**Install Winch per winch instructions.**

The room allotted for winches by Jeep is limited. Some winches are therefore tight and are likely to contact the grill. This is normal.







After Install:

- Tighten all bolts securing purchased parts to specified locations.
- After completing installation using provided instructions, go through all steps again to make sure nothing was missed, not tightened or improperly assembled.
- Some components may need to be purchased separately.
- Check turn signals, headlights, fog lights (if applicable), taillights, blinkers and windshield wipers.
- Adjust mirrors, speedometer and headlights if needed.
- Make sure all gauges are fully operational.
- Drive the vehicle slowly for a couple minutes, looking and listening for abnormal noises while driving. After modification of a vehicle there will be differences in driving experiences and capabilities, be mindful of that.
- Inspect and Retorque all Bolts after 500 miles of completed installation and regularly thereafter.
- Some modification may be required.

Recommended Torque:

Size	Grade 2		Grade 5		Grade 8		18-8 S/S	
	Coarse	Fine	Coarse	Fine	Coarse	Fine	Coarse	Fine
<b>#4*</b>	-	-	-	-	-	-	5.2	-
<b>#6*</b>	-	-	-	-	-	-	9.6	-
<b>#8*</b>	-	-	-	-	-	-	19.8	-
<b>#10*</b>	-	-	-	-	-	-	22.8	31.7
<b>1/4</b>	4	4.7	6.3	7.3	9	10	6.3	7.8
<b>5/16</b>	8	9	13	14	18	20	11	11.8
<b>3/8</b>	15	17	23	26	33	37	20	22
<b>7/16</b>	24	27	37	41	52	58	31	33
<b>1/2</b>	37	41	57	64	80	90	43	45
<b>9/16</b>	53	59	82	91	115	129	57	63
<b>5/8</b>	73	83	112	128	159	180	93	104
<b>3/4</b>	125	138	200	223	282	315	128	124
<b>7/8</b>	129	144	322	355	454	501	194	193
<b>1+</b>	188	210	483	541	682	764	287	289



EVO Manufacturing

Jeep Wrangler JK/JL and JT Gladiator

JK/JL/JT Quarter Pounder Front Bumper

EVO- 3057/B/AL



**Important:** Keep hardware pack containing jog plate and jog plate hardware.





Before starting installation procedure please read <http://evomfg.com>Returns-Warranties-Shipping>

**CAREFULLY READ AND FOLLOW ALL INSTRUCTIONS IN THIS MANUAL AND KEEP FOR FUTURE REFERENCE. IF YOU HAVE ANY QUESTIONS ABOUT THE PRODUCT CALL EVO MANUFACTURING. FAILURE TO FOLLOW GUIDELINES COULD RESULT IN MALFUNCTION OF PARTS OR INJURY. PLEASE HAVE A TRAINED PROFESSIONAL ASSIST WITH OR INSTALL ALL PRODUCTS. INSTALLING EVO MFG PRODUCTS OR KITS DEMANDS SPECIFIC KNOWLEDGE, TOOLS AND EXPERIENCE. GENERAL KNOWLEDGE OF HOW TO USE LATER SPECIFIED TOOLS AND/OR LIMITED EXPERIENCE WITH EVO MFG PRODUCTS MAY NOT BE ENOUGH TO PROPERLY COMPLETE THESE TASKS. SOME OF EVO MFG PRODUCTS MAY REQUIRE TWO OR MORE PEOPLE TO INSTALL SAFELY AND CORRECTLY. DO NOT ATTEMPT ALONE, ALWAYS ENLIST THE HELP OF TRAINED PROFESSIONAL WHEN NEEDED.**

**Notes: Set Up Before installation**

**Cutting and grinding will be necessary for this installation.**

**May need to use a second person to ease install.**

**Keep all mounting bolts loose (installed but not torqued) we will torque later at the end of complete installation**

**READ BEFORE INSTALL:**

It is generally a good idea to apply Loctite to all threaded bolts.

ALWAYS wear safety glasses and other approved safety gear when working on a vehicle.

All supplied bolts torqued according to chart at end of instruction.

It is recommended all installation be performed by a trained professional. Some modification may have to be done.

Paint all unfinished surfaces after install is complete.

On aluminum bumpers, heat should not be applied due to aluminum properties



Parts included: Table below shows EVO MFG Quarter Pounder Bumper.

Description	#	Part # B	Part # AL	Quantity
¼ Pounder Stubby Bumper	1	EVO-10038B	EVO-10038AL	1
Spacer Plate	2	EVO-10037B	EVO-10037AL	6
Hardware Pack	3	EVO-770014	EVO-770014	1
Jog Plate	4	EVO-12033B	EVO-10039AL	1
Jog Plate Hardware Pack	5	EVO-770045	EVO-770045	1

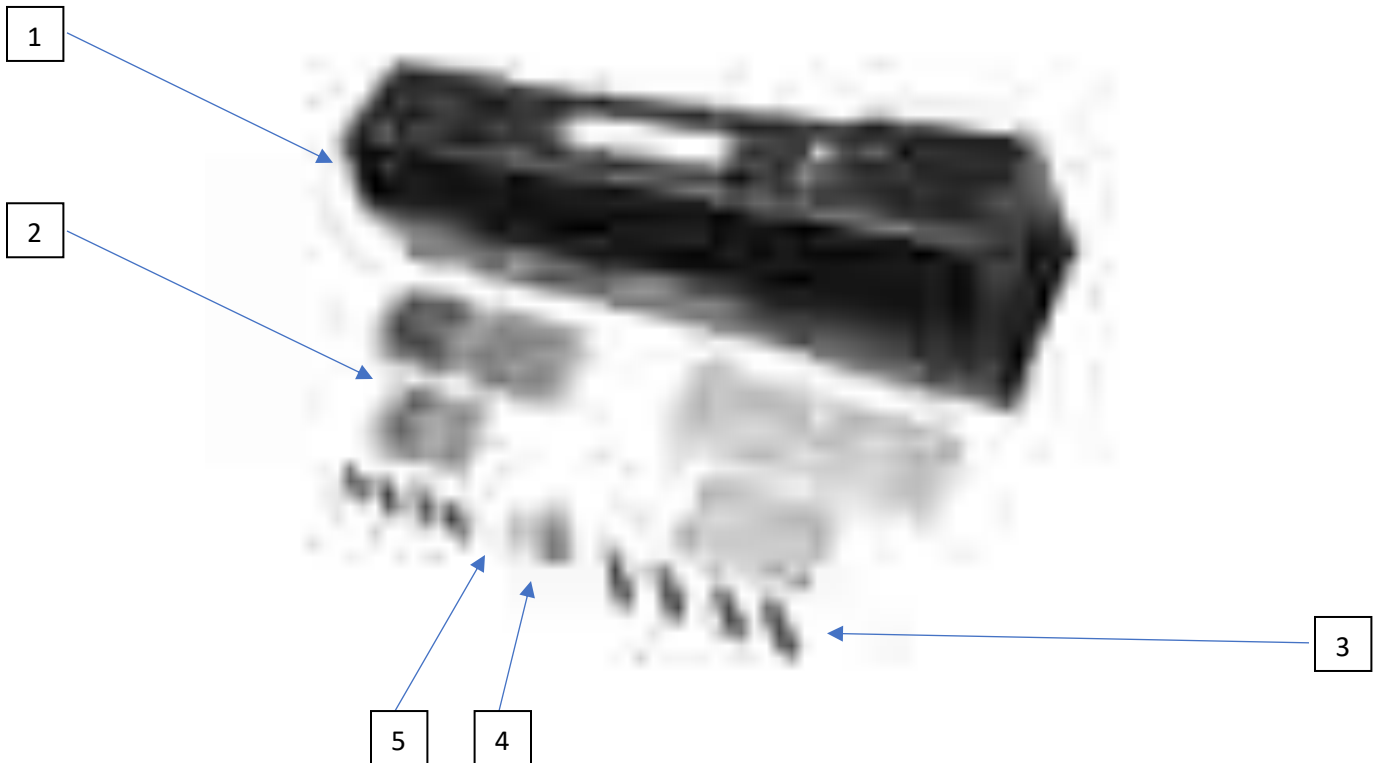

**Do not discard hardware pack containing jog plate and jog plate hardware. Critical for winch install.**



#### **Recommended Tools:**

- Allen set/ Driver Sockets
  - Impact with standard sockets
  - Sawzall/Cut off wheel or similar
  - Drill and ½" bit/ Step bit
- 



#### **Safety Steps for installation**

- For installing EVO MFG products always use wheel chokes to block rear tires from rolling.
  - Always make sure you have everything necessary ready before install.
  - If you have to, carefully lift front of vehicle by front frame rails extending suspension until tires leave the ground, place frame on approved jack stands for vehicle. Verify all lines/wires are not over extended.
  - Remove tires if needed for easier install.
  - Make sure to wear safety equipment (eye protection, hand protection, foot protection etc.) at all times during installation.
  - Make sure all safety precautions have been taken.
  - Always check and replace any part of vehicle that is worn or broken before starting install.
  - Do not mix anything EVO with weaker alternatives.
  - It is generally a good idea to apply liquid threadlock to all bolts.
  - Tighten included hardware to torque specifications in bottom table unless it is otherwise specified, factory bolts should be torqued to factory Jeep specifications.
- 





Various factory bumper options are available. Factory bumper removal steps therefore will vary. This is just a guide, follow factory manual if further instruction is required.

### **INSTALL:**

Safely park car on flat ground, put in park and chock wheels.

---

1. Remove factory front bumper by removing the 8 nuts on the inside of the bumper and remove the push clips on underside of bumper.
- 





2. Remove wires from fog lamps, remove bulbs (if applicable). Reference Jeep manual for removal of bulb, different year and models may vary.
- 



3. For JL and JTs remove the factory frame plates. This will not be reused.
- 



4. Remove upper factory plastic in front of grill. Start by removing plastic clips/screws then pull out plastic.
- 





5. Mark cut lines as shown. For the JK the cut line should be drawn right above crossmember on tabs that hold crossmember to frame bracket.
- 

JK cut line:



6. For the JL and JT the cut line should be drawn right above the bend in the frame bracket as shown.
- 

JL/JT cut line:







7. Using a Sawzall, cut off wheel or similar, remove/cut the lower front cross member using cut lines. Cut front and back of both sides on crossmember.

---

Use proper safety precautions and safety equipment. Make sure no wires are in the cutting path. Only cut specified area.

---



For installing winch:

If a winch is to be installed. Follow the directions that came with your winch and mount to the inner 4 bolt pattern on the inside of the ¼ Pounder. The EVO MFG Quarter Pounder bumper will accept center mount winches as well as offset winches.

---



For fairlead adjustment using the included EVO fairlead jog plate: Using jog plate hardware kit, mount jog plate to correct side of fairlead mount depending on type of winch. Put washer on bolt, then insert through bumper then jog plate, tighten nut onto backside of bolt.

Mount EVO Fairlead Jog Plate on passenger side for Offset Winch

---

Mount EVO Fairlead Jog Plate on driver side for Centered Winch

---





Verify that the supplied  $\frac{1}{2}$ " bolts will insert through all the 8 factory holes in your Jeeps frame. If not, drill the holes that do not fit with a  $\frac{1}{2}$ " drill.

8. Using the supplied hardware (2.0" without DRings, 2.5" with D-rings/Stinger all with washers) install through the upper right and left holes of both sides (4 Bolts total).

If you are using the EVO DRings/Stinger, these should be mounted at this time on the outer face of the bumper.

9. To space bumper forwards, on the inside face of the  $\frac{1}{4}$  Pounder, the Jeep JK will need two spacer plates per side on the inside mounting face of the bumper (in front of frame). For the Jeep JL and JT you will need three spacer plates.
10. Install  $\frac{1}{4}$  Pounder with spacer plates to factory frame.
11. Install supplied washers and nuts and 4 remaining lower bolts.
12. Torque all nuts to 80 lb/ft .





Optional Rubicon electronic sway bar mount relocation:

13. Remove bolt from the front mount of the swaybar motor. (long bolt that goes through the rubber isolator)

14. The motor will now freely rotate on the axis of the swaybar.

15. Rotate the swaybar motor rearward as much as possible.

---



16. With a 1/2" diameter drill mark off 1/2" from tip down on the drill with tape.

17. You may need to loosen the two bolts on the passenger side frame rail that holds the swaybar to the frame to get your drill to drill straight into the new mounting hole.

---



18. In the new mounting hole, drill from the passenger side toward the center of the vehicle 1/2" deep (up to tape mark) into new mounting hole. DO NOT DRILL MORE THAN 1/2".

19. Using the same bolt removed earlier install through the factory rubber isolator and into the newly drilled hole.

---





After Install:

- Tighten all bolts securing purchased parts to specified locations.
- After completing installation using provided instructions, go through all steps again to make sure nothing was missed, not tightened or improperly assembled.
- Some components may need to be purchased separately.
- Check turn signals, headlights, fog lights (if applicable), taillights, blinkers and windshield wipers.
- Adjust mirrors, speedometer and headlights if needed.
- Make sure all gauges are fully operational.
- Drive the vehicle slowly for a couple minutes, looking and listening for abnormal noises while driving. After modification of a vehicle there will be differences in driving experiences and capabilities, be mindful of that.
- Inspect and Retorque all Bolts after 500 miles of completed installation and regularly thereafter.
- Some modification may be required.

Recommended Torque:

Size	Grade 2		Grade 5		Grade 8		18-8 S/S	
	Coarse	Fine	Coarse	Fine	Coarse	Fine	Coarse	Fine
<b>#4*</b>	-	-	-	-	-	-	5.2	-
<b>#6*</b>	-	-	-	-	-	-	9.6	-
<b>#8*</b>	-	-	-	-	-	-	19.8	-
<b>#10*</b>	-	-	-	-	-	-	22.8	31.7
<b>1/4</b>	4	4.7	6.3	7.3	9	10	6.3	7.8
<b>5/16</b>	8	9	13	14	18	20	11	11.8
<b>3/8</b>	15	17	23	26	33	37	20	22
<b>7/16</b>	24	27	37	41	52	58	31	33
<b>1/2</b>	37	41	57	64	80	90	43	45
<b>9/16</b>	53	59	82	91	115	129	57	63
<b>5/8</b>	73	83	112	128	159	180	93	104
<b>3/4</b>	125	138	200	223	282	315	128	124
<b>7/8</b>	129	144	322	355	454	501	194	193
<b>1†</b>	188	210	483	541	682	764	287	289



EVO Manufacturing

2.5"/4.5"/6.5" Jeep Wrangler JT Gladiator 2018+

Enforcer Kit Instruction Manual

For all: EVO-3060, EVO-3061, EVO-3062, EVO-3063, EVO-3064, EVO-3065 Kits

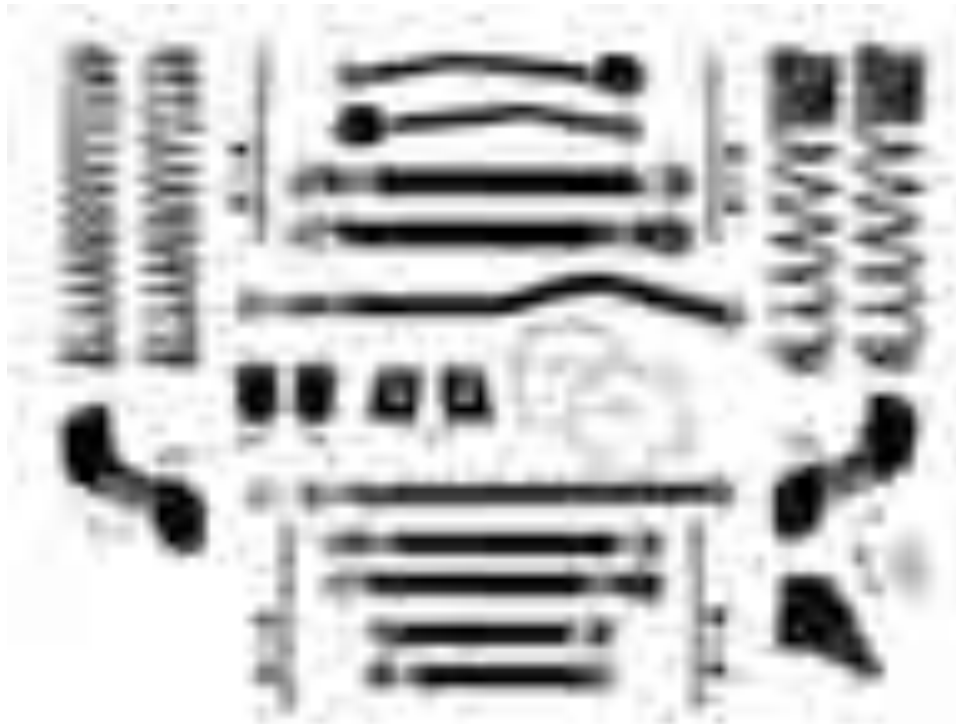



Before starting installation procedure please read <http://evomfg.com>Returns-Warranties-Shipping>

---

**CAREFULLY READ AND FOLLOW ALL INSTRUCTIONS IN THIS MANUAL AND KEEP FOR FUTURE REFERENCE. IF YOU HAVE ANY QUESTIONS ABOUT THE PRODUCT CALL EVO MANUFACTURING. FAILURE TO FOLLOW GUIDELINES COULD RESULT IN MALFUNCTION OF PARTS OR INJURY. PLEASE HAVE A TRAINED PROFESSIONAL ASSIST WITH OR INSTALL ALL PRODUCTS. INSTALLING EVO MFG PRODUCTS OR KITS DEMANDS SPECIFIC KNOWLEDGE, TOOLS AND EXPERIENCE. GENERAL KNOWLEDGE OF HOW TO USE LATER SPECIFIED TOOLS AND/OR LIMITED EXPERIENCE WITH EVO MFG PRODUCTS MAY NOT BE ENOUGH TO PROPERLY COMPLETE THESE TASKS. SOME OF EVO MFG PRODUCTS MAY REQUIRE TWO OR MORE PEOPLE TO INSTALL SAFELY AND CORRECTLY. DO NOT ATTEMPT ALONE, ALWAYS ENLIST THE HELP OF TRAINED PROFESSIONAL WHEN NEEDED.**

**READ BEFORE INSTALL:**

**After alignment is complete and no additional adjusts are to be made to control arms. Torque all 1" Jam Nuts to 250 ft/lbs and all 1-1/4" Jam Nuts torque to 300 ft/lbs. Regularly check all jam nuts and punch bolts on all Enforcer control arms for proper torque/tightness. Failure to do so may cause premature wear of threads on arms.**

- For Overland Kits ONLY, Minor grinding/clearance of oe frame upper link bracket may be needed.
- 2.5" JT Enforcer/Enforcer Overland kits with either EVO shock extension kit or shocks 28 7/8" extended or less do not require driveshafts.
- All models will require wheels spacers or aftermarket wheels with 5" or smaller number backspacing.
- All factory bolts should be tightened to factory specifications.
- All supplied bolts torqued according to chart at end of instruction.
- It is recommended all installation be performed by a trained professional.
- Some modification may have to be done in order to fit preferred tire or tire brand/size.
- For the JT Gladiator you will have to remove break lines and install supplied stainless braided lines.
- Loosely install all bracket hardware, do not tighten until all hardware is installed.
- Minor grinding/clearance of oe frame upper link bracket may be needed.
- Loosely install. Only tighten/torque trackbar bolts after vehicle is at ride height under it's own weight. Never tighten when suspension is extended.



**Notes: Set Up Before installation**

4.5"/6.5" Gladiator Lifts: Front Lower and Rear Upper Adjustable Control Arms and Front & Rear Adjustable Trackbars are required for proper alignment/install. These are included with Stage 3 and Stage 4 "PLUS" Kits

**FRONT LOWER JT ENFORCER ARM STARTING LEGNTH CENTER TO CENTER**

For 2.5" lift set control arm length to 24 1/8"

For 4.5" lift set control arm length to 24 1/2"

For 6.5" lift set control arm length to 24 3/4"

**FRONT UPPER JT ENFORCER ARM STARTING LEGNTH CENTER TO CENTER 20 1/4"**

**REAR LOWER JT ENFORCER ARM STARTING LEGNTH CENTER TO CENTER 23 3/4"**

**REAR UPPER JT ENFORCER ARM STARTING LEGNTH CENTER TO CENTER**

For 2.5" lift, set upper control arm length to 16 1/2"

For 4.5" lift, set upper control arm length to 16 5/8"

For 6.5" lift, set upper control arm length to 17"

**DO NOT exceed 17 1/4"**

**STARTING LENGTH FOR FRONT TRACK BAR CENTER TO CENTER**

For 2.5" lift set track bar to 34 1/4"

For 4.5" lift set track bar to 34 9/16"

For 6.5" lift set track bar to 34 3/4"

**Do NOT exceed 35"**

**STARTING LENGTH FOR REAR TRACKBAR CENTER TO CENTER**

For 2.5" lift set track bar to 33 9/16"

For 4.5" lift set track bar to 33 9/16"

For 6.5" lift set track bar to 33 5/8"

**Do NOT exceed 35"**

ALL measurements stated above are starting points only, every vehicle is different. Professional alignment is recommended.

For all Stage 4 lifts add 3/8" to all control arm measurements stated above. The measurements are starting measurements and not exact measurements for every vehicle, A professional alignment is recommended.

Keep all control arm mounting bolts loose (installed but not torqued) we will torque later at the end of installation

6.5" Gladiator kits may require EVO-3027B Front Shock Relocation kit or similar. It is recommended and not included.

Align to factory specifications. Recommended caster 5 Degrees +/- .5



Parts included: Table below shows Stage 4 Overland PLUS kit, other Stages might not include same components.

Description	#	Part # 2.5" lift	Part # 4.5" lift	Part # 6.5" Lift	Qty
Front Left Coil (Standard/DIESEL-HD)	1	600160 600197	600164 600195	600150 600199	1
Front Right Coil (Standard/DIESEL-HD)	2	600161 600197	600165 600195	600151 600199	1
Rear Left Coil (Standard/DIESEL-HD)	3	600162 600163	600166 600167	600152 600153	1
Rear Right Coil (Standard/DIESEL-HD)	4	600163 600163	600167 600167	600153 600153	1
Front Upper Control Arms D,P	5	EVO-3007B	EVO-3007B	EVO-3007B	1
Front Lower Control Arms D,P	6	EVO-3006B	EVO-3006B	EVO-3006B	1
Rear Lower Control Arms	7	EVO-3082	EVO-3082	EVO-3082	1
Rear Upper Control Arms D,P	8	EVO-3081	EVO-3081	EVO-3081	1
Sway Bar Link fr,rr	9	12029B,12329B	12029B,12329B	12027B,12027RB	2
Front Bump Stop Spacer	10	20039	20005	20005	2
Rear Bump Stop Bracket	11	12418B	12419B	12420B	2
Front/rear Brake Line	12	600132,600170	600132,600170	600132,600170	2
EVO Enforcer Hardware Kit	13	770077	770077	770077	1
Sway Bar Bushings	14	600077	600077	600077	8
Sway Bar Sleeve	15	20032	20032	20032	8
Rear Track Bar Bracket	16	EVO-12423B	EVO-12423B	EVO-12423B	1
Front Trackbar	17	EVO-3047B	EVO-3047B	EVO-3047B	1
Rear Trackbar	18	EVO-3049B	EVO-3049B	EVO-3049B	1
Overland Brackets	19	EVO-3003B	EVO-3003B	EVO-3003B	2



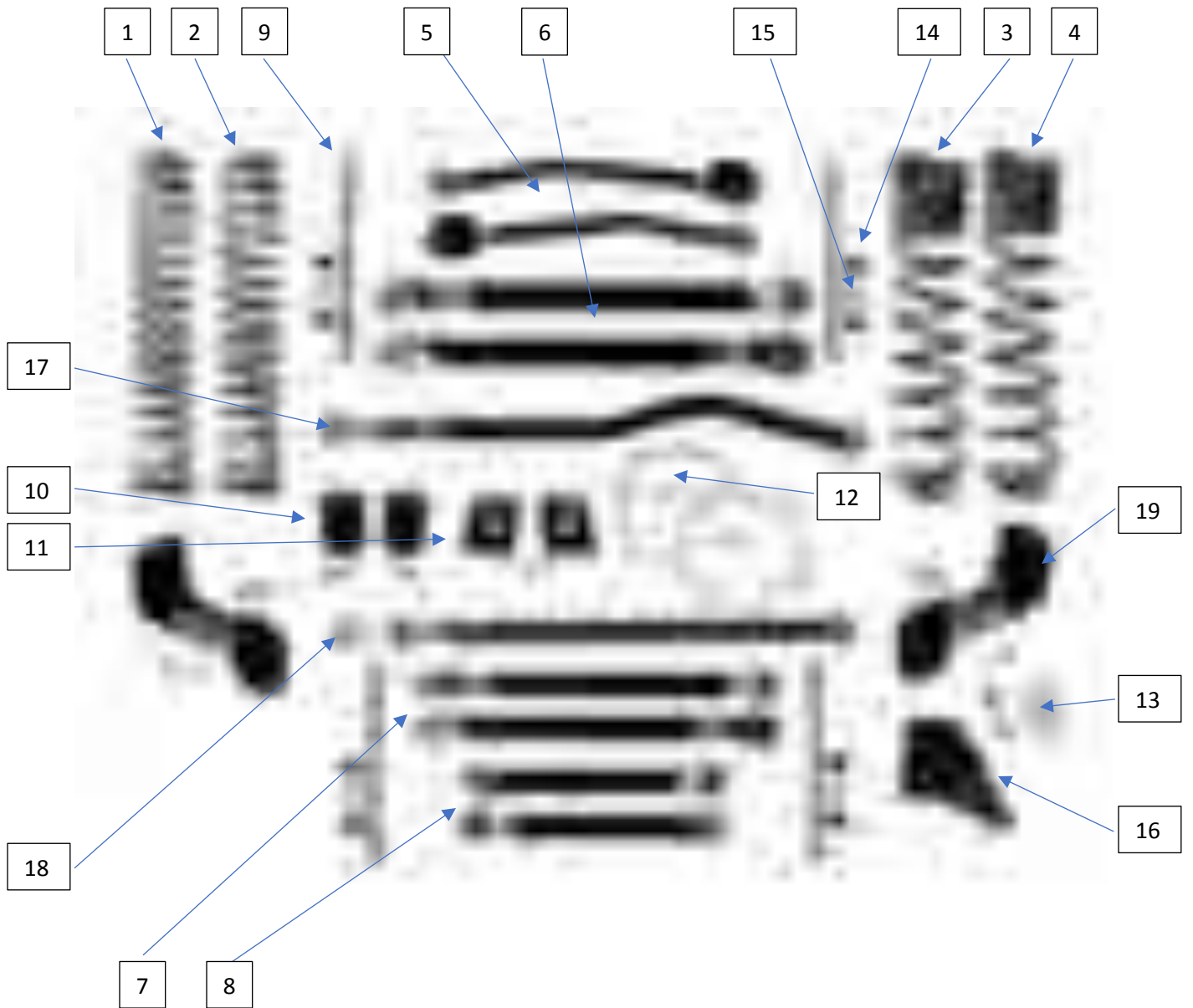

**Note:** If installing EVO MFG Enforcer Control Arms: All Vehicles that spend time on salted roads. It is recommended that removal of control arm joint (threaded one) on all EVO control arms before installation of vehicle. Apply a small amount of Anti Seize on threads and reassemble.



#### **Recommended Tools:**

- Impact with socket set
- Wrenches (English/metric)
- Screwdriver
- Vehicle jack
- Jack stand
- Drill and ½" bit
- WD40
- Rubber Mallet/Vice
- Dremel/knife/shears
- Thread lock
- Vice grips
- Grinder
- Vehicle approved brake fluid



---

#### Safety Steps for installation

- For installing EVO MFG products always use wheel chokes to block rear tires from rolling.
- Always make sure you have everything necessary ready before install.
- If you have to, carefully lift front of vehicle by front frame rails extending suspension until tires leave the ground, place frame on approved jack stands for vehicle. Verify all lines/wires are not over extended.
- Remove tires if needed for easier install.
- Make sure to wear safety equipment (eye protection, hand protection, foot protection etc.) at all times during installation.
- Make sure all safety precautions have been taken.
- Always check and replace any part of vehicle that is worn or broken before starting install.
- Do not mix anything EVO with weaker alternatives.
- It is generally a good idea to apply liquid threadlock to all bolts.
- Tighten included hardware to torque specifications in bottom table unless it is otherwise specified, factory bolts should be torqued to factory Jeep specifications.





## Front Install

1. Remove bolt from driver and passenger side brake line bracket at frame just behind front coils.
2. Remove both driver and passenger side swaybar links bolts at axle and swaybar removing swaybar links and rotate sway up and out of the way. Factory front links will not be reused.

---

**There is a 6mm allen key inside both driver and passenger side upper sway bar studs. Use allen head to allow nut to unscrew.**

---





1. Disconnect push-in clip from front upper control arm mounts at axle holding wire. Un clip all other wires/hoses that are connected to axle.

**Vehicle wiring and hoses vary, make sure all wires, hoses, lines etc. from frame to axle are freed up giving ample length to move axle downward as needed before proceeding, verify wiring/hoses etc. do not get stretched while lowering axle in next steps.**



---

#### **Support driver side axle with jack stand**

2. **IF** you are **replacing shocks** and not using shock extensions remove upper bolt. Otherwise leave shock mounted at upper.
3. Lightly jack the front driver side axle tube slightly. With axle slightly supported remove front lower shock bolt from axle.
4. Repeat on passenger side.

**Varying axle jack tension to the right amount will alleviate load on the bolt and allow it to freely slide out.**

---





5. Remove trackbar bolt at axle.

**This will allow the axle to move side to side so be cautious about this from here on.**

6. Lower jack under axle giving room and remove front spring.



7. After removing all parts specified in the above steps, the lower control arms might bind when lowering the axle. If you remove the axle side control arm bolts, do so **one side at a time**.

Use extreme caution, only remove one lower control arm bolt, replace the spring and then reinstall control arm bolt before doing so on the other side.





8. Insert supplied 3/8 x 2" bolt into front bumpstop extension. Place bumpstop with bolt inside (bore side up) EVO MFG Front Coil spring. Install coil spring with rubber isolator on top of coil into its original location on both the frame and axle.

**Axle may need to be lowered to install. Verify correct part number spring in correct location per table on page 3.**

9. With spring in place and bumpstop extension sitting on axle pad and bolt inserted into bumpstop extension. Install supplied 3/8" nut from under spring pad to bolt inserted inside bump stop extension and tighten



Note: Make sure factory coil seats stay in the factory locations, Left coil seat on the left and right on the right, etc. Also make sure that the rubber pins insert into holes on coil brackets.

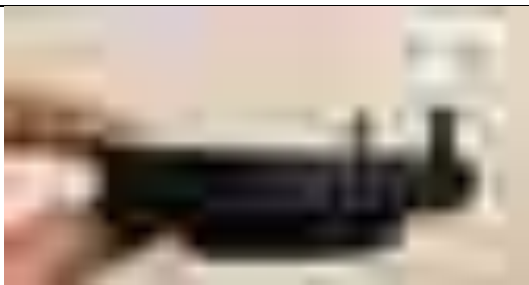



**If you are installing Overland kit with Front Control Arm Relocation brackets. Follow the below bullet points: If not installing OVERLAND Kit continue to next numbered step.**

- With axle and frame/vehicle safely supported. Loosen but do not remove bolt or nut on both upper and lower control arm bolts at their axle connections.
- Remove heat shield from upper control arm at frame and unbolt driver side upper control arm from frame.
- Unbolt lower control arm at frame

**Being very cautious and careful as the axle will no longer be connected to vehicle on the driver side at this time.**

- Rotate control arms out of the way and insert driver side control arm relocation brackets into frame pockets where control arms were once mounted. Factory frame upper link bracket may need to be slightly ground to line upper bolt hole.
- In both upper and lower arm location where bracket connects with frame insert supplied crush tube into gaps (shorter sleeve for upper mount and longer tube for lower mount). Use factory bolts to frame locations through EVO brackets and crush sleeves.
- Torque all frame bolts at EVO control arm brackets to factory specifications.
- Rotate control arms back into their new location on the EVO Control arm relocation brackets. Use Supplied M12 bolt, washers and nut for upper control arm





mount and 5/8 bolt, washers, nut  
for lower control arm mount.

---

10. Using a 15mm socket remove the banjo bolt from caliper, Remove the banjo bolt from the brake hose, remove the copper washers.
  11. Remove bolt and bracket holding the brake line on the axle tube using a 10mm wrench, located under spring bracket.
  12. Moving swiftly/carefully separate the hard line from the bracket/hose on frame by holding hardline with a 12mm wrench and unscrewing the rubber hose with a 16mm wrench.
- 



13. Install new copper crush washers on to the factory banjo bolt, Insert the factory banjo bolt with copper crush washer on through the banjo of the new stainless steel brake line, then slip another copper crush washer on.
- 







14. Using a 15mm socket, secure your new stainless steel break line to the break caliper using factory hardware, tighten the banjo bolt to 276 in. lbs. of torque **(at caliper hard line elbow extends towards front of vehicle and angled up as much as possible.)**
- 



15. The mid line retaining bracket on new steel braided brake line needs to be installed using factory 10mm bolt at previous axle mounting location.
- 



16. Use a 12mm wrench to hold hardline and a 19mm wrench to secure your new stainless steel brake line to mounting bracket on the frame.
  17. Repeat previous brake line procedures on opposite front brake line.
  18. Check the fluid level in your master cylinder. Bleed front brakes following factory procedures.
- 

**Note:** Carefully move line. Do not crimp/pinch line. Always check for leaking fluids and that brakes work correctly. Bleeding brakes is extremely important to be done properly. Follow factory specifications in doing so. Consultation/should be performed by a trained professional mechanic.



19. Assemble supplied front swaybar links. Using light oil such as WD 40, lubricate inner surface of link loops. Tap or vice in supplied rubber bushings. Lubricate inner surface of rubber bushings. Tap or vice in supplied swaybar tube sleeves. Use longer sway bar link pair in rear, shorter pair in front.

---



20. If you are installing shock extensions. Do so at this time. Follow instructions for that kit. If you are installing new shocks, follow shock manufacturers specifications and install shocks at both upper and lower mounting locations.

---





21. Reinstall wheels and torque to factory specifications. Carefully lift vehicle by frame, remove jack stands and lower to ground. **When lowering be mindful of the front trackbar at axle this is not bolted in.** It will need to be guided into the bracket at the axle while lowering the vehicle.
- 



If installing new EVO MFG front trackbar, do so at this time using factory hardware. To align/install trackbar correctly make sure the bend in the trackbar is facing upwards, forward and above the pumpkin/diff.

22. When on the ground carefully turn steering with engine running. Vehicle in park and with parking brake on and wheels chalked. This will slowly move vehicle left and right to align trackbar bolt. Once trackbar lines up with hole in trackbar bracket, insert factory bolt and loosely tighten bolt.



**While on ground under Jeeps own weight at ride height, torque all control arm bolts, uppers, lowers at frame and axle. Torque all shock bolts at frame and axle. Torque front trackbar bolt. Check and torque all other bolts. Use chart below for supplied hardware. Use factory specifications for factory hardware.**



## Rear Install

23. While safely parked on ground. Loosen all rear control arm and trackbar bolts at both axle and frame. DO NOT REMOVE. Just loosen a few turns to remove bolt compression on control arm bushings.

---



If installing EVO MFG Enforcer arms. Do so at this time. Remove and replace one arm at a time. Keep bolts loose (installed but un-torqued) as described above. We will torque later in the installation process.

Make sure zerker fittings are facing up and adjustable end at axle.

---



24. Carefully lift rear of vehicle by frame rails/crossmember extending suspension until the tires leave the ground.

25. Securely place weight approved jack stands for vehicle under frame

**With vehicle rear tires now suspended and frame securely supported on stands, remove rear tires from vehicle.**

---





26. While vehicle is on jacks, remove the carrier bearing bolts and retain them for a 2.5" lifts. The 4.5" and 6.5" lifts supply longer bolts. Add the supplied carrier bearing spacers in between carrier bearing bracket and mounting holes on crossmember.

For 2.5" lift install two 12440 carrier bearing spacers reusing two factory bolts

For 4.5" lift install three 12440 spacers with the two supplied 900443 bolts.

For 6.5" lift install four 12440 spacers with the two supplied 900443 bolts.

**Apply Loctite to all bolts**



27. Remove both driver and passenger side swaybar links bolts at axle and swaybar removing swaybar links and rotate sway down and out of the way.

**There is a 6mm allen key inside both driver and passenger side rear upper sway bar bolts. Tighten the allen head to allow nut to unscrew.**





**Vehicle wiring and hoses vary, make sure all wires, hoses, lines etc from chassis to axle are freed up giving ample length to move axle downward as needed before proceeding, verify wiring/hoses etc do not get stretched while lowering axle in next steps.**

28. Lightly jack front driver side axle tube slightly. Support driver side axle with jack stand
29. With axle slightly supported remove lower shock bolt from axle.
30. Repeat this step on passenger side.

**Varying axle jack tension to the right amount will alleviate load on the bolt and allow it to freely slide out.**

**If you are replacing shocks and not using shock extensions remove upper bolt and remove shock. Otherwise leave shock mounted at upper.**

Repeat on passenger side

---



31. Remove the two bolts holding caliper to axle, then remove the smaller speed sensor bolt and pull the sensor out of brake assembly.

32. Pull off calipers and sensor and support caliper assembly by frame. **Do not hang calipers by brake line.**

**Do not remove brake line at this time.**





33. Lower jack under axle giving room and remove rear springs.
34. Install rear bump stop extensions to axle pads on both passenger and driver side axle pads using supplied 5/16" x .75 bolts, washers and nuts.
35. Install EVO Rear Coil spring and with factory rubber isolator on top of coil into the factory coil springs locations. Axle may need to be lowered to install. Verify correct part number spring in correct location per table page 2.

Repeat on passenger side

---



36. Reinstall the caliper and speed sensor on both sides of axle. Tighten bolts to Jeep specifications.

**Note:** Carefully move brake line. Do not crimp/pinch line. Always check for leaking fluids and that brakes work correctly.

---





37. Assemble supplied rear swaybar links. Using light oil such as WD 40, lubricate inner surface of link loops. Tap or vice in supplied rubber bushings. Lubricate inner surface of rubber bushings. Tap or vice in supplied swaybar tube sleeves. Use longer sway bar link pair in rear, shorter pair in front.
38. With rear spring installed. Jack axle up until shock bolts line up with axle mounting holes. **Be very aware that vehicle does not lift off chassis/frame jack stands while jacking.** If you are installing new shocks or shock extensions, do so at this time. Follow factory torque specs for shock bolts.
- 







39. Using a 15mm socket remove the banjo bolt from caliper, Remove the banjo bolt from the brake hose, remove the copper washers.

40. Remove bolt and bracket holding the brake line on the axle tube using a 10mm wrench, located under spring bracket.

41. Moving swiftly/carefully separate the hard line from the bracket/hose on frame by holding hardline with a 12mm wrench and unscrewing the rubber hose with a 16mm wrench.

---



42. Install new copper crush washers on to the factory banjo bolt, Insert the factory banjo bolt with copper crush washer on through the banjo of the new stainless steel brake line, then slip another copper crush washer on.

---





43. Using a 15mm socket, secure your new stainless steel break line to the break caliper using factory hardware, tighten the banjo bolt to 276 in. lbs. of torque **(at caliper hard line elbow extends towards front of vehicle and angled up as much as possible.)**
- 



44. The mid line retaining bracket on new steel braided brake line needs to be installed using factory 10mm bolt at previous axle mounting location.
- 



45. Use a 12mm wrench to hold hardline and a 19mm wrench to secure your new stainless steel brake line to mounting bracket on the frame.
46. Repeat previous brake line procedures on opposite front brake line.
47. Check the fluid level in your master cylinder. Bleed front brakes following factory procedures.

**Note:** Carefully move line. Do not crimp/pinch line. Always check for leaking fluids and that brakes work correctly. Bleeding brakes is extremely important to be done properly. Follow factory specifications in doing so. Consultation/should be performed by a trained professional mechanic.



**FOR ENFORCER/ENFORCER OVERLAND  
4.5"/6.5" KIT ONLY.**

- Remove rear trackbar bolt at axle. Move trackbar down under/out of factory bracket. Swing trackbar above axle bracket.
- Take EVO bracket with U bolt side on the right, place it on the axle tube, slide the EVO bracket onto factory bracket from right to left. **EVO bracket slides into factory trackbar bracket not over the top.**
- At lower original bolt mounting location, insert supplied crush sleeve into bracket and loosely install supplied bolt at this location. Loosely install supplied U Bolt at axle tube.
- On driver side of bracket with bracket loosely installed, drill 3/8" hole through factory bracket. Install supplied hardware.
- Torque all bracket bolts.
- Insert trackbar into new higher trackbar location from the top down. Loosely install factory trackbar bolt. Do not torque trackbar bolt at this time. This should be done on the ground at ride height later in this installation.

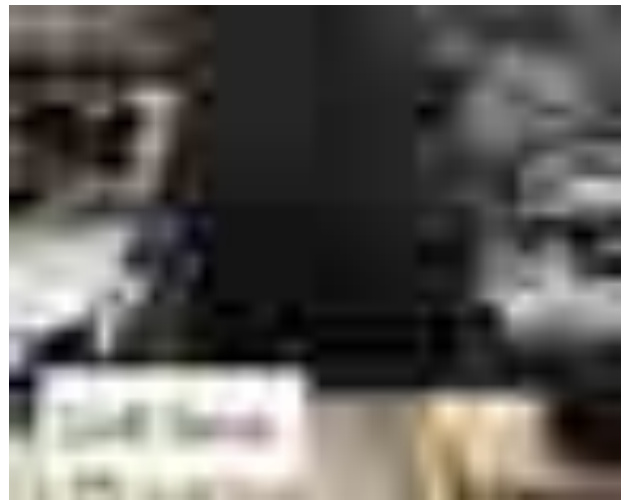

---

48. Using zip tie loosely secure rubber gromet on abs line to new brake line once installed.

Do NOT tighten more than a few clicks after being loosely secured.

---





49. Once vehicle is on the ground, if you have the EVO MFG upper control arms then adjust them out until pinion is facing the transfer case. The angle of your driveshaft and angle of your pinion should have zero degrees difference between the two. **The driveshaft face and pinion face should be parallel with each other.**
- 



#### **Finishing up:**

- Reconnect all disconnected hoses, wires etc.
- Align to factory specifications. Recommended caster 5 Degrees +/- .5
- Depending on shock length the parking brake cables may need to be unhooked from the hook on the sub frame above driveshaft.
- Reinstall (all) rear wheels
- Carefully jack vehicle by frame and remove jack stands.
- Lower vehicle to ground.
- **With vehicle parked securely on level ground at ride height with parking brake engaged and wheels chalked. Torque all control arm bolts, uppers, lowers front and rear at frame and axle. Torque all shock bolts at frame and axle. Torque front and rear trackbar bolts. Torque wheels. Check and torque all other bolts. Use chart below for supplied hardware. Use factory specifications for factory hardware. Double check everything is tight at this time.**

RECENTER STEERING WHEEL by Adjusting Turn buckle on Draglink. Make sure to turn the correct way to center (do not do a full rotation of steering wheel, closest direction to straight, watch wheel while turning) and pinch nuts once straight. You may need to do this more than once after a drive to get it straight to your liking. Test brakes and verify no leakage in lines before driving. Recheck often. Removal or trimming of factory plastic inner fender liner may be required to clear combinations of larger tire sizes and wheel back spacings. Check for acceptable clearance. Retorque all bolts after 500 miles. **After alignment is complete and no additional adjusts are to be made to control arms. Torque all 1" Jam Nuts to 250 ft/lbs and all 1-1/4" Jam Nuts torque to 300 ft/lbs. Regularly check all jam nuts and punch bolts on all Enforcer control arms for proper torque/tightness. Failure to do so may cause premature wear of threads on arms.**



#### After Install:

- Double check all brake lines for leaks and or loose bolts. Make sure brakes are bled and bled properly. It is recommended to take to a professional to bleed brakes properly.
- Tighten all bolts securing urethane or rubber bushings once vehicle is under its own weight and at ride height. Track bars, control arms, etc.
- After completing installation using provided instructions, go through all steps again to make sure nothing was missed, not tightened or improperly assembled.
- Some components may need to be purchased separately.
- Check turn signals, headlights, fog lights (if applicable), taillights, blinkers and windshield wipers.
- Adjust mirrors, speedometer and headlights if needed.
- Make sure all gauges are fully operational.
- Drive the vehicle slowly for a couple minutes, looking and listening for abnormal noises while driving. After modification of a vehicle there will be differences in driving experiences and capabilities, be mindful of that.
- Inspect and Retorque all Bolts after 500 miles of completed installation and regularly thereafter.
- For 4.5" or taller you will need a front track bar (included in plus "P" kit) or order EVO-3047B separately.
- Some modification may be required to fit preferred size/brand tire.
- Loosely install. Only tighten/torque trackbar bolts after vehicle is at ride height under it's own weight. Never tighten when suspension is extended.
- **Regularly check all jam nuts and punch bolts on all Enforcer control arms for proper torque/tightness. Failure to do so may cause premature wear of threads on arms.**



**Recommended Torque:**

Size	Grade 2		Grade 5		Grade 8		18-8 S/S	
	Coarse	Fine	Coarse	Fine	Coarse	Fine	Coarse	Fine
<b>#4*</b>	-	-	-	-	-	-	5.2	-
<b>#6*</b>	-	-	-	-	-	-	9.6	-
<b>#8*</b>	-	-	-	-	-	-	19.8	-
<b>#10*</b>	-	-	-	-	-	-	22.8	31.7
<b>1/4</b>	4	4.7	6.3	7.3	9	10	6.3	7.8
<b>5/16</b>	8	9	13	14	18	20	11	11.8
<b>3/8</b>	15	17	23	26	33	37	20	22
<b>7/16</b>	24	27	37	41	52	58	31	33
<b>1/2</b>	37	41	57	64	80	90	43	45
<b>9/16</b>	53	59	82	91	115	129	57	63
<b>5/8</b>	73	83	112	128	159	180	93	104
<b>3/4</b>	125	138	200	223	282	315	128	124
<b>7/8</b>	129	144	322	355	454	501	194	193
<b>1†</b>	188	210	483	541	682	764	287	289



EVO Manufacturing  
Jeep Wrangler JT Gladiator  
JT Bomber Rockers  
EVO- 3070





Before starting installation procedure please read <http://evomfg.com>Returns-Warranties-Shipping>

**CAREFULLY READ AND FOLLOW ALL INSTRUCTIONS IN THIS MANUAL AND KEEP FOR FUTURE REFERENCE. IF YOU HAVE ANY QUESTIONS ABOUT THE PRODUCT CALL EVO MANUFACTURING. FAILURE TO FOLLOW GUIDELINES COULD RESULT IN MALFUNCTION OF PARTS OR INJURY. PLEASE HAVE A TRAINED PROFESSIONAL ASSIST WITH OR INSTALL ALL PRODUCTS. INSTALLING EVO MFG PRODUCTS OR KITS DEMANDS SPECIFIC KNOWLEDGE, TOOLS AND EXPERIENCE. GENERAL KNOWLEDGE OF HOW TO USE LATER SPECIFIED TOOLS AND/OR LIMITED EXPERIENCE WITH EVO MFG PRODUCTS MAY NOT BE ENOUGH TO PROPERLY COMPLETE THESE TASKS. SOME OF EVO MFG PRODUCTS MAY REQUIRE TWO OR MORE PEOPLE TO INSTALL SAFELY AND CORRECTLY. DO NOT ATTEMPT ALONE, ALWAYS ENLIST THE HELP OF TRAINED PROFESSIONAL WHEN NEEDED.**

**Notes: Set Up Before installation**

**This product requires permanent drilling of holes into the body of the Jeep and installing threaded inserts. Once process has started there is no going back.**

**Rivnuts/Nutserts are used in this installation. Installation tool for this is required and not included. Thread Size ¼-20**

**Always wear approved safety equipment while performing the installation.**

**It is recommended that EVO MFG Bombers/Skins are installed uncoated/painted first, then coat/paint and perform final assembly.**

**Keep all mounting bolts loose (installed but not torqued) we will torque later at the end of complete installation**

**READ BEFORE INSTALL:**

It is generally a good idea to apply Loctite to all threaded bolts.

ALWAYS wear safety glasses and other approved safety gear when working on a vehicle.

All supplied bolts torqued according to chart at end of instruction.

It is recommended all installation be performed by a trained professional. Some modification may have to be done.





Parts included: Table below shows Jeep Gladiator Bomber Rockers.

Description	#	Part #	Quantity
Bomber Rockers Driver	1	EVO-12400	1
Bomber Rockers Passenger	2	EVO-12401	1
Front/Mid Pinch Seam Mount	3	EVO-12353	4
Mid/Rear Pinch Seam Mount	4	EVO-12354	4
Rocker Step Hardware	5	EVO-770083	1
Rear Body Mount Plate Driver	6	EVO-12421	1
Rear Body Mount Plate Passenger	7	EVO12422	1
Forward Bodymount Crush Tube	8	EVO-12355	2

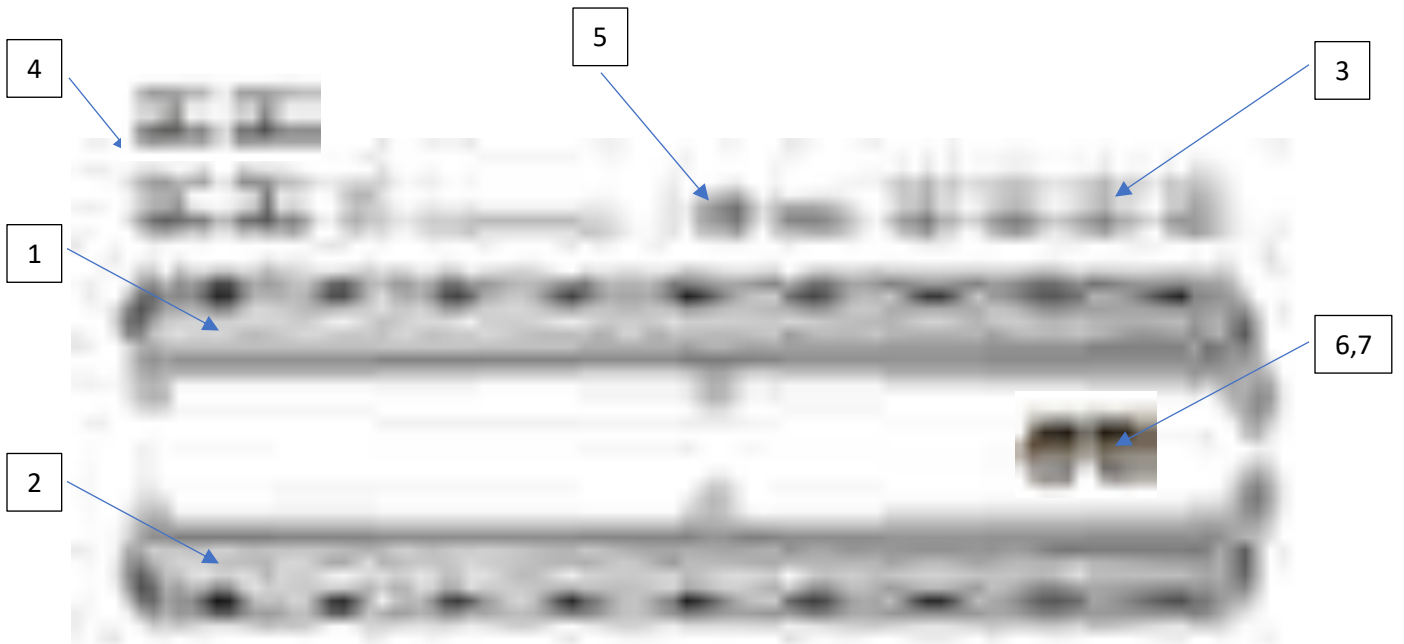



#### **Recommended Tools:**

- Allen set
  - Impact with standard sockets
  - Nutsert install tool
  - Drill and bit
- 



#### **Safety Steps for installation**

- For installing EVO MFG products always use wheel chokes to block rear tires from rolling.
  - Always make sure you have everything necessary ready before install.
  - If you have to, carefully lift front of vehicle by front frame rails extending suspension until tires leave the ground, place frame on approved jack stands for vehicle. Verify all lines/wires are not over extended.
  - Remove tires if needed for easier install.
  - Make sure to wear safety equipment (eye protection, hand protection, foot protection etc.) at all times during installation.
  - Make sure all safety precautions have been taken.
  - Always check and replace any part of vehicle that is worn or broken before starting install.
  - Do not mix anything EVO with weaker alternatives.
  - It is generally a good idea to apply liquid threadlock to all bolts.
  - Tighten included hardware to torque specifications in bottom table unless it is otherwise specified, factory bolts should be torqued to factory Jeep specifications.
- 





Park vehicle on flat ground, parking brake engaged and chalk wheels.

1. Uninstall front body mount bolt. Loosen (do not remove) middle and rearward body mount bolts.
- 





2. Loosely preassemble inner seam mounts to main bomber rails. The inner seam mounts with the 4-center hole pattern will be used at both front and front/middle locations. The inner seam mount with the 2-center hole pattern will be used at the rear and rear/middle locations.
- 



3. Using the supplied 3/8" hardware, loosely install all 8 bolts from bottom up at all 4 inner seam mount locations (2 each mount). It is best to tighten these to the point just before getting tight (loose but almost tight). This will save time later during final install while tightening all bolts on the vehicle.

On top side of bomber, install all 4 seam mount button head bolts completely.

---





4. Install rear body mount plate to bomber using 3/8" hardware.

Mount the plate with slotted end facing upwards. Attach the plate on the top side of rear mounting holes of bomber. Use 2 of the supplied 3/8" bolt and nut.

---



5. Install all button head bolts into bomber bolt hole locations (see picture for reference).
- 





6. With the help of 2 people, lift Bomber into location and insert front and rear bolts into existing pinch seam holes at body. Loosely install washer and nut. This will loosely hold part in place.
  7. Insert spacer tube in gap between Bomber and front body mount. Loosely (just before tightening) install the supplied M12 bolt with washer at this front body mount location.
  8. Reinstall the middle and rear body mount bolts, just before tight.
- 



9. Using the factory holes in body pinch seam install supplied 5/16" bolts and washers through body and into inner seam mounts.
- 

On 5/16" bolts, install bolts with washer on head side only. The inside nut is a flange nut, no washers are used on flange nut.





When all bolts in parts are installed, apply an inward pressure on bomber, tighten body mount bolts.

---



Then tighten all pinch seam bolts.

---

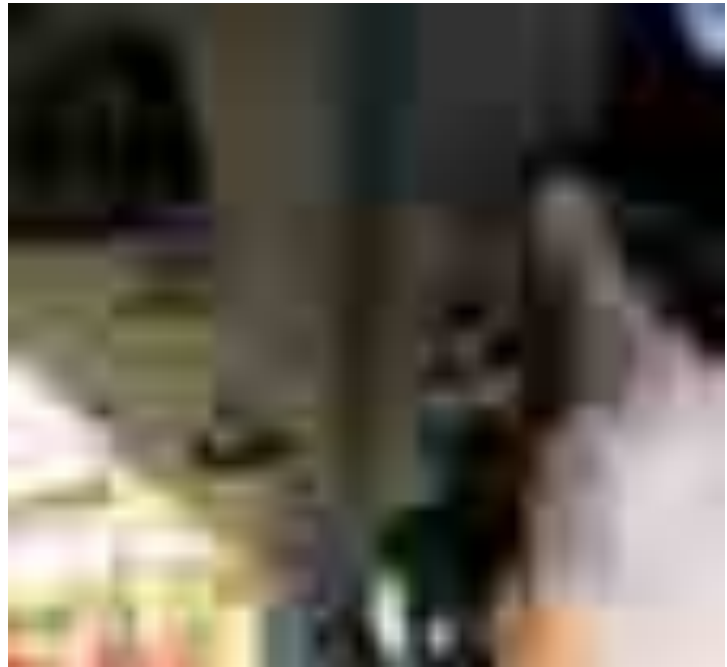



After Install:

- Tighten all bolts securing purchased parts to specified locations.
- After completing installation using provided instructions, go through all steps again to make sure nothing was missed, not tightened or improperly assembled.
- Some components may need to be purchased separately.
- Check turn signals, headlights, fog lights (if applicable), taillights, blinkers and windshield wipers.
- Adjust mirrors, speedometer and headlights if needed.
- Make sure all gauges are fully operational.
- Drive the vehicle slowly for a couple minutes, looking and listening for abnormal noises while driving. After modification of a vehicle there will be differences in driving experiences and capabilities, be mindful of that.
- Inspect and Retorque all Bolts after 500 miles of completed installation and regularly thereafter.
- Some modification may be required.

Recommended Torque:

Size	Grade 2		Grade 5		Grade 8		18-8 S/S	
	Coarse	Fine	Coarse	Fine	Coarse	Fine	Coarse	Fine
<b>#4*</b>	-	-	-	-	-	-	5.2	-
<b>#6*</b>	-	-	-	-	-	-	9.6	-
<b>#8*</b>	-	-	-	-	-	-	19.8	-
<b>#10*</b>	-	-	-	-	-	-	22.8	31.7
<b>1/4</b>	4	4.7	6.3	7.3	9	10	6.3	7.8
<b>5/16</b>	8	9	13	14	18	20	11	11.8
<b>3/8</b>	15	17	23	26	33	37	20	22
<b>7/16</b>	24	27	37	41	52	58	31	33
<b>1/2</b>	37	41	57	64	80	90	43	45
<b>9/16</b>	53	59	82	91	115	129	57	63
<b>5/8</b>	73	83	112	128	159	180	93	104
<b>3/4</b>	125	138	200	223	282	315	128	124
<b>7/8</b>	129	144	322	355	454	501	194	193
<b>1†</b>	188	210	483	541	682	764	287	289





EVO Manufacturing

Jeep Wrangler JT Gladiator

JT Bomber Rockers with Rock Skin

EVO- 3071





Before starting installation procedure please read <http://evomfg.com>Returns-Warranties-Shipping>

**CAREFULLY READ AND FOLLOW ALL INSTRUCTIONS IN THIS MANUAL AND KEEP FOR FUTURE REFERENCE. IF YOU HAVE ANY QUESTIONS ABOUT THE PRODUCT CALL EVO MANUFACTURING. FAILURE TO FOLLOW GUIDELINES COULD RESULT IN MALFUNCTION OF PARTS OR INJURY. PLEASE HAVE A TRAINED PROFESSIONAL ASSIST WITH OR INSTALL ALL PRODUCTS. INSTALLING EVO MFG PRODUCTS OR KITS DEMANDS SPECIFIC KNOWLEDGE, TOOLS AND EXPERIENCE. GENERAL KNOWLEDGE OF HOW TO USE LATER SPECIFIED TOOLS AND/OR LIMITED EXPERIENCE WITH EVO MFG PRODUCTS MAY NOT BE ENOUGH TO PROPERLY COMPLETE THESE TASKS. SOME OF EVO MFG PRODUCTS MAY REQUIRE TWO OR MORE PEOPLE TO INSTALL SAFELY AND CORRECTLY. DO NOT ATTEMPT ALONE, ALWAYS ENLIST THE HELP OF TRAINED PROFESSIONAL WHEN NEEDED.**

**Notes: Set Up Before installation**

**This product requires permanent drilling of holes into the body of the Jeep and installing threaded inserts. Once process has started there is no going back.**

**Rivnuts/Nutserts are used in this installation. Installation tool for this is required and not included. Thread size 1/4 -20**

**Always wear approved safety equipment while performing the installation.**

**It is recommended that EVO MFG Bombers/Skins are installed uncoated/painted first, then coat/paint and perform final assembly.**

**Keep all mounting bolts loose (installed but not torqued) we will torque later at the end of complete installation**

**READ BEFORE INSTALL:**

It is generally a good idea to apply Loctite to all threaded bolts.

ALWAYS wear safety glasses and other approved safety gear when working on a vehicle.

All supplied bolts torqued according to chart at end of instruction.

It is recommended all installation be performed by a trained professional. Some modification may have to be done.



Parts included: Table below shows Jeep Gladiator Bomber Rockers with Rock Skins.

Description	#	Part #	Quantity
Bomber Rockers Driver	1	EVO-12400	1
Bomber Rockers Passenger	2	EVO-12401	1
Front/Mid Pinch Seam Mount	3	EVO-12353	4
Mid/Rear Pinch Seam Mount	4	EVO-12354	4
Rocker Step Hardware	5	EVO-770083	1
Rock Skin Driver	6	EVO-12402	1
Rock Skin Passenger	7	EVO-12403	1
Rear Body Mount Plate Driver	8	EVO-12421	1
Rear Body Mount Plate Passenger	9	EVO-12422	1
Forward Bodymount Crush Tube	10	EVO-12355	2
Hardware	11	EVO-770084	1





#### **Recommended Tools:**

- Allen set
  - Impact with standard sockets
  - Nutsert install tool
  - Drill and bit
- 



#### **Safety Steps for installation**

- For installing EVO MFG products always use wheel chokes to block rear tires from rolling.
  - Always make sure you have everything necessary ready before install.
  - If you have to, carefully lift front of vehicle by front frame rails extending suspension until tires leave the ground, place frame on approved jack stands for vehicle. Verify all lines/wires are not over extended.
  - Remove tires if needed for easier install.
  - Make sure to wear safety equipment (eye protection, hand protection, foot protection etc.) at all times during installation.
  - Make sure all safety precautions have been taken.
  - Always check and replace any part of vehicle that is worn or broken before starting install.
  - Do not mix anything EVO with weaker alternatives.
  - It is generally a good idea to apply liquid threadlock to all bolts.
  - Tighten included hardware to torque specifications in bottom table unless it is otherwise specified, factory bolts should be torqued to factory Jeep specifications.
- 





Park vehicle on flat ground,  
parking brake engaged and  
chalk wheels.

1. Clean both sets of EVO  
MFG Rock Skins.
- 





2. Hold EVO MFG Rock Skin to vehicle and align Rock Skin using body lines/door openings. Once you find a fit that works for you, mark the 4 centermost holes between the doors.

**Before drilling it is the installers responsibility to verify fitment is acceptable. There is no turning back from here.**

3. Once the skins are in your acceptable position, using the 4 marked holes in the Rock Skin drill through the outer sheet metal of body only using a 25/64" drill bit.



Step Drill recommended

4. Follow manufacturers tool procedure and install nutserts into 4 drilled holes.





5. Replace EVO MFG Rock Skin on the side of the vehicle and bolt to body (snug) in the 4 locations with installed nutserts. DO NOT overtighten bolts.
  6. Once Skin is bolted to body, press Skin flush to body, mark all other holes for drilling. Forward and rearward of center.
  7. Remove Skin from body. Follow tool procedure to drill holes and insert remaining nutserts.
- 



8. Loosely install Rock Skin at all bolt locations and repeat previous steps on alternate side.
- 





9. Uninstall front body mount bolt. Loosen (do not remove) middle and rearward body mount bolts.
- 



10. Loosely preassemble inner seam mounts to main bomber rails. The inner seam mounts with the 4-center hole pattern will be used at both front and front/middle locations. The inner seam mount with the 2-center hole pattern will be used at the rear and rear/middle locations.
- 







11. Using the supplied 3/8" hardware, loosely install all 8 bolts from bottom up at all 4 inner seam mount locations (2 each mount). It is best to tighten these to the point just before getting tight (loose but almost tight). This will save time later during final install while tightening all bolts on the vehicle.

On top side of bomber, install all 4 seam mount button head bolts completely.

---



12. Install rear body mount plate to bomber using 3/8" hardware.

Mount the plate with slotted end facing upwards. Attach the plate on the top side of rear mounting holes of bomber. Use 2 of the supplied 3/8" bolt and nut.

---





13. With the help of two people, lift Bomber into location setting bomber onto Rock Skin tabs while inserting rear and middle body mount tabs into loosened body mount bolts.

14. Once bomber is placed on Rock Skins, loosely install all button head bolts in remaining Rock Skin to Bomber bolt locations.

---



15. Insert spacer tube in gap between Bomber and front body mount.

16. Loosely (just before tightening) install the supplied M12 bolt with washer at this front body mount location.

17. Reinstall the middle body mount bolt, just before tight.

---





18. Using the factory holes in body pinch seam install supplied 5/16" bolts and washers through body and into inner seam mounts.

---

On 5/16" bolts, install bolts with washer on head side only. The inside nut is a flange nut, no washers are used on flange nut.



When all bolts in parts are installed, apply an inward pressure on bomber, tighten body mount bolts.

---





Then tighten all pinch  
seam bolts.

---



Lastly tighten down Rock  
Skin bolts.

---





After Install:

- Tighten all bolts securing purchased parts to specified locations.
- After completing installation using provided instructions, go through all steps again to make sure nothing was missed, not tightened or improperly assembled.
- Some components may need to be purchased separately.
- Check turn signals, headlights, fog lights (if applicable), taillights, blinkers and windshield wipers.
- Adjust mirrors, speedometer and headlights if needed.
- Make sure all gauges are fully operational.
- Drive the vehicle slowly for a couple minutes, looking and listening for abnormal noises while driving. After modification of a vehicle there will be differences in driving experiences and capabilities, be mindful of that.
- Inspect and Retorque all Bolts after 500 miles of completed installation and regularly thereafter.
- Some modification may be required.

Recommended Torque:

Size	Grade 2		Grade 5		Grade 8		18-8 S/S	
	Coarse	Fine	Coarse	Fine	Coarse	Fine	Coarse	Fine
<b>#4*</b>	-	-	-	-	-	-	5.2	-
<b>#6*</b>	-	-	-	-	-	-	9.6	-
<b>#8*</b>	-	-	-	-	-	-	19.8	-
<b>#10*</b>	-	-	-	-	-	-	22.8	31.7
<b>1/4</b>	4	4.7	6.3	7.3	9	10	6.3	7.8
<b>5/16</b>	8	9	13	14	18	20	11	11.8
<b>3/8</b>	15	17	23	26	33	37	20	22
<b>7/16</b>	24	27	37	41	52	58	31	33
<b>1/2</b>	37	41	57	64	80	90	43	45
<b>9/16</b>	53	59	82	91	115	129	57	63
<b>5/8</b>	73	83	112	128	159	180	93	104
<b>3/4</b>	125	138	200	223	282	315	128	124
<b>7/8</b>	129	144	322	355	454	501	194	193
<b>1†</b>	188	210	483	541	682	764	287	289



EVO Manufacturing  
Jeep Wrangler JT Gladiator 2019+  
Gladiator Bed Rack Instruction Manual  
EVO- 3073/B, EVO- 3074/B





Before starting installation procedure please read <http://evomfg.com>Returns-Warranties-Shipping>

---

**CAREFULLY READ AND FOLLOW ALL INSTRUCTIONS IN THIS MANUAL AND KEEP FOR FUTURE REFERENCE. IF YOU HAVE ANY QUESTIONS ABOUT THE PRODUCT CALL EVO MANUFACTURING. FAILURE TO FOLLOW GUIDELINES COULD RESULT IN MALFUNCTION OF PARTS OR INJURY. PLEASE HAVE A TRAINED PROFESSIONAL ASSIST WITH OR INSTALL ALL PRODUCTS. INSTALLING EVO MFG PRODUCTS OR KITS DEMANDS SPECIFIC KNOWLEDGE, TOOLS AND EXPERIENCE. GENERAL KNOWLEDGE OF HOW TO USE LATER SPECIFIED TOOLS AND/OR LIMITED EXPERIENCE WITH EVO MFG PRODUCTS MAY NOT BE ENOUGH TO PROPERLY COMPLETE THESE TASKS. SOME OF EVO MFG PRODUCTS MAY REQUIRE TWO OR MORE PEOPLE TO INSTALL SAFELY AND CORRECTLY. DO NOT ATTEMPT ALONE, ALWAYS ENLIST THE HELP OF TRAINED PROFESSIONAL WHEN NEEDED.**

**Notes: Set Up Before installation**

**Make sure to clean top of bed sides and below bed lip.**

**May require 2 persons to ease install.**

**Keep all mounting bolts loose (installed but not torqued) we will torque later at the end of complete installation, after all bolts are loosely installed.**

**READ BEFORE INSTALL:**

It is generally a good idea to apply Loctite to all threaded bolts.

ALWAYS wear safety glasses and other approved safety gear when working on a vehicle.

All supplied bolts torqued according to chart at end of instruction.

It is recommended all installation be performed by a trained professional. Some modification may have to be done.

It is advised to not carry items at high speeds that can create lift (upward force to due to wind)



Parts included: Table below shows black (painted) Gladiator Bed Rack.

Description	#	Part #	Quantity
Driver Side Upright	1	EVO-12411	1
Crossmembers	2	EVO-12413	1
Hardware	3	EVO-770087	1
Passenger Side Upright	4	EVO-12415	1

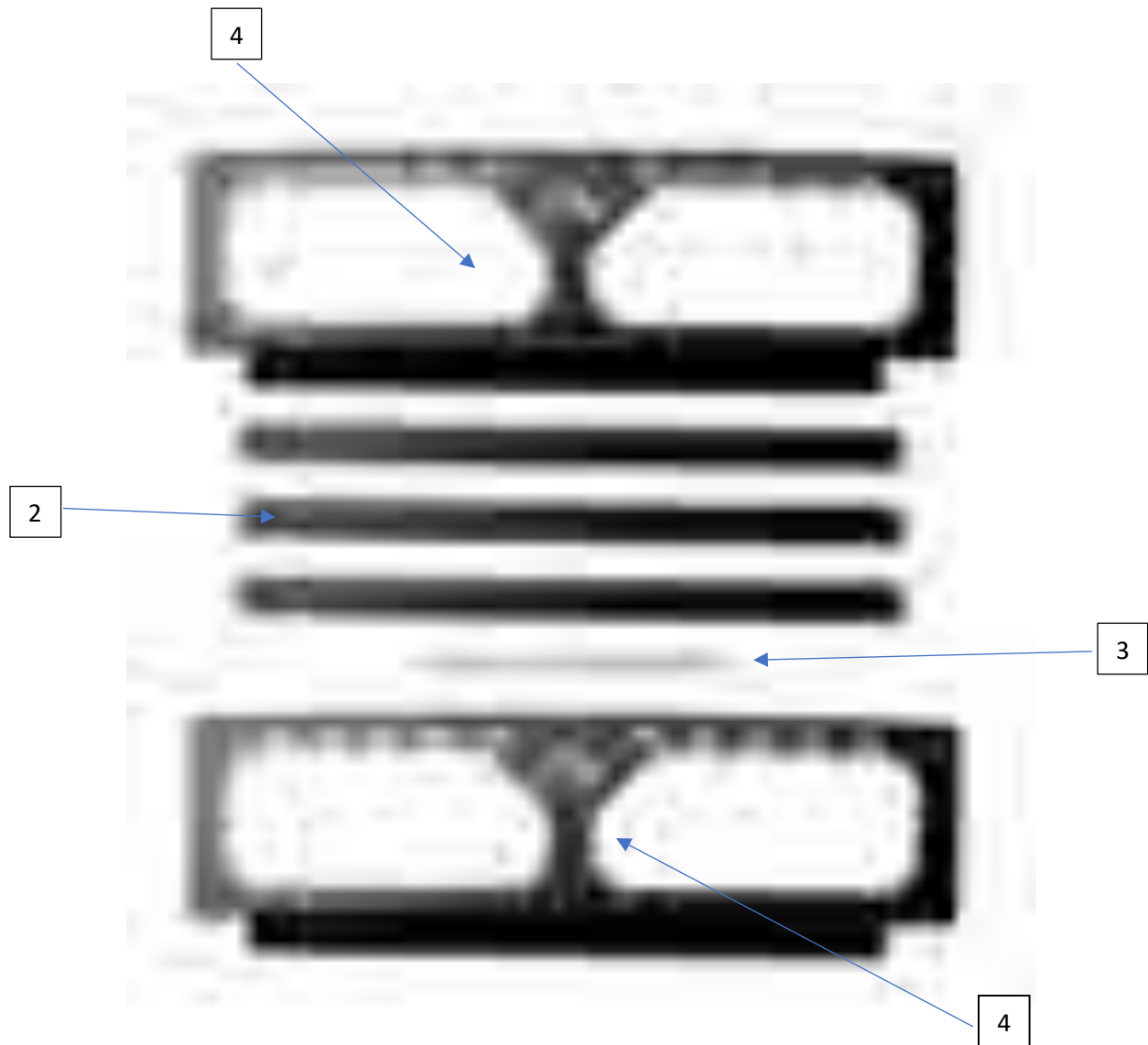

**Note:** Leave all hardware installed loosely until end of installation.





#### **Recommended Tools:**

- Loctite
- Standard Wrench Set



#### Safety Steps for installation

- For installing EVO MFG products always use wheel chokes to block rear tires from rolling.
- Always make sure you have everything necessary ready before install.
- If you have to, carefully lift front of vehicle by front frame rails extending suspension until tires leave the ground, place frame on approved jack stands for vehicle. Verify all lines/wires are not over extended.
- Remove tires if needed for easier install.
- Make sure to wear safety equipment (eye protection, hand protection, foot protection etc.) at all times during installation.
- Make sure all safety precautions have been taken.
- Always check and replace any part of vehicle that is worn or broken before starting install.
- Do not mix anything EVO with weaker alternatives.
- It is generally a good idea to apply liquid threadlock to all bolts.
- Tighten included hardware to torque specifications in bottom table unless it is otherwise specified, factory bolts should be torqued to factory Jeep specifications.





1. Place one side of EVO MFG side upright flush onto top of truck bedside, make sure the EVO cutout side of the upright is on top and facing out.



2. Maneuver lower bracketry of upright where horizontal bend is flush on top of bedside and vertical bend is flush with inside of bedside.
- 



3. Insert M8 washer onto all M8 bolts. With washer on bolt, bolt bed rack upright onto the side of truck bed in the 4 holes located below the top lip of the bed (as pictured) Tighten but do not torque.



Only install one side at this time.

---



4. Assemble all cross members onto the installed upright.
5. Use the supplied hardware to loosely secure each crossmember to the upright at the three hole locations (pictured).

Make sure cross members are installed underneath top bend of upright. (Use picture for reference)

---



6. Insert the opposite upright where the horizontal bend at the bottom of upright sits on top of bedside and lower vertical bend is flush with inside of bedside. (pictured)
  7. Attach top side of upright into crossmembers (crossmembers seated below top bend of upright) Use picture for reference.
- 



8. Insert M8 bolts and install into the 4 bolt holes below top lip of bedside.
  9. Install hardware into the three holes in each crossmember to marry the crossmembers to the upright.
- 





10. With all bolts loosely installed, manipulate the rack until best fit is obtained.
11. Torque all hardware using specified table on last page. M8 bolts torqued to 18 ft/lbs



After Install:

- Tighten all bolts securing purchased parts to specified locations.
- After completing installation using provided instructions, go through all steps again to make sure nothing was missed, not tightened or improperly assembled.
- Some components may need to be purchased separately.
- Check turn signals, headlights, fog lights (if applicable), taillights, blinkers and windshield wipers.
- Adjust mirrors, speedometer and headlights if needed.
- Make sure all gauges are fully operational.
- Drive the vehicle slowly for a couple minutes, looking and listening for abnormal noises while driving. After modification of a vehicle there will be differences in driving experiences and capabilities, be mindful of that.
- Inspect and Retorque all Bolts after 500 miles of completed installation and regularly thereafter.
- Some modification may be required.



Recommended Torque:

Size	Grade 2		Grade 5		Grade 8		18-8 S/S	
	Coarse	Fine	Coarse	Fine	Coarse	Fine	Coarse	Fine
<b>#4*</b>	-	-	-	-	-	-	5.2	-
<b>#6*</b>	-	-	-	-	-	-	9.6	-
<b>#8*</b>	-	-	-	-	-	-	19.8	-
<b>#10*</b>	-	-	-	-	-	-	22.8	31.7
<b>1/4</b>	4	4.7	6.3	7.3	9	10	6.3	7.8
<b>5/16</b>	8	9	13	14	18	20	11	11.8
<b>3/8</b>	15	17	23	26	33	37	20	22
<b>7/16</b>	24	27	37	41	52	58	31	33
<b>1/2</b>	37	41	57	64	80	90	43	45
<b>9/16</b>	53	59	82	91	115	129	57	63
<b>5/8</b>	73	83	112	128	159	180	93	104
<b>3/4</b>	125	138	200	223	282	315	128	124
<b>7/8</b>	129	144	322	355	454	501	194	193
<b>1+</b>	188	210	483	541	682	764	287	289



EVO Manufacturing  
Jeep Wrangler JT Gladiator 2019+  
Gladiator Bed Rack Instruction Manual  
EVO- 3073/B, EVO- 3074/B





Before starting installation procedure please read <http://evomfg.com>Returns-Warranties-Shipping>

---

**CAREFULLY READ AND FOLLOW ALL INSTRUCTIONS IN THIS MANUAL AND KEEP FOR FUTURE REFERENCE. IF YOU HAVE ANY QUESTIONS ABOUT THE PRODUCT CALL EVO MANUFACTURING. FAILURE TO FOLLOW GUIDELINES COULD RESULT IN MALFUNCTION OF PARTS OR INJURY. PLEASE HAVE A TRAINED PROFESSIONAL ASSIST WITH OR INSTALL ALL PRODUCTS. INSTALLING EVO MFG PRODUCTS OR KITS DEMANDS SPECIFIC KNOWLEDGE, TOOLS AND EXPERIENCE. GENERAL KNOWLEDGE OF HOW TO USE LATER SPECIFIED TOOLS AND/OR LIMITED EXPERIENCE WITH EVO MFG PRODUCTS MAY NOT BE ENOUGH TO PROPERLY COMPLETE THESE TASKS. SOME OF EVO MFG PRODUCTS MAY REQUIRE TWO OR MORE PEOPLE TO INSTALL SAFELY AND CORRECTLY. DO NOT ATTEMPT ALONE, ALWAYS ENLIST THE HELP OF TRAINED PROFESSIONAL WHEN NEEDED.**

**Notes: Set Up Before installation**

**Make sure to clean top of bed sides and below bed lip.**

**May require 2 persons to ease install.**

**Keep all mounting bolts loose (installed but not torqued) we will torque later at the end of complete installation, after all bolts are loosely installed.**

**READ BEFORE INSTALL:**

It is generally a good idea to apply Loctite to all threaded bolts.

ALWAYS wear safety glasses and other approved safety gear when working on a vehicle.

All supplied bolts torqued according to chart at end of instruction.

It is recommended all installation be performed by a trained professional. Some modification may have to be done.

It is advised to not carry items at high speeds that can create lift (upward force to due to wind)



Parts included: Table below shows black (painted) Gladiator Bed Rack.

Description	#	Part #	Quantity
Driver Side Upright	1	EVO-12411	1
Crossmembers	2	EVO-12413	1
Hardware	3	EVO-770087	1
Passenger Side Upright	4	EVO-12415	1

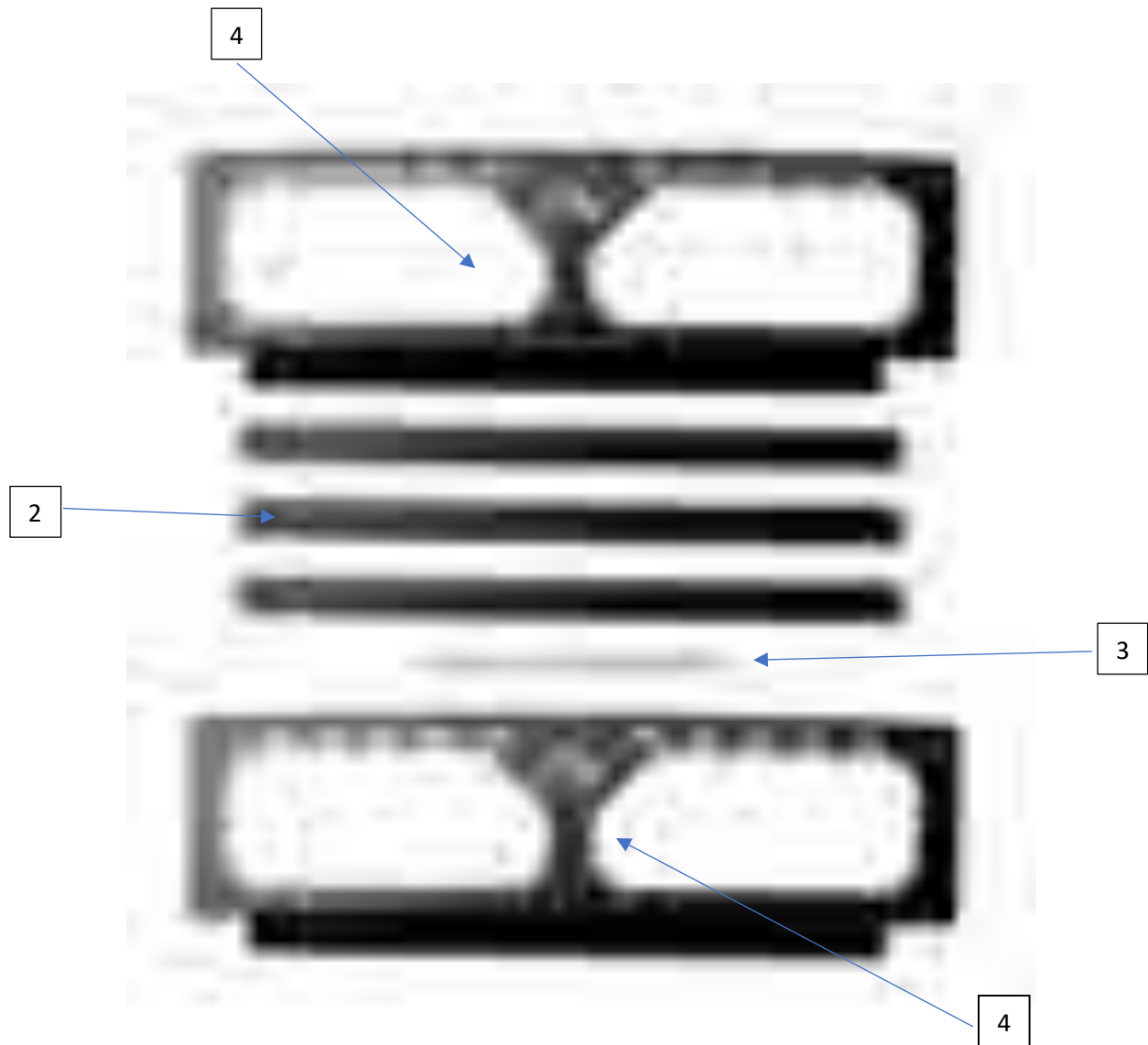

**Note:** Leave all hardware installed loosely until end of installation.





#### **Recommended Tools:**

- Loctite
  - Standard Wrench Set
- 



#### **Safety Steps for installation**

- For installing EVO MFG products always use wheel chokes to block rear tires from rolling.
  - Always make sure you have everything necessary ready before install.
  - If you have to, carefully lift front of vehicle by front frame rails extending suspension until tires leave the ground, place frame on approved jack stands for vehicle. Verify all lines/wires are not over extended.
  - Remove tires if needed for easier install.
  - Make sure to wear safety equipment (eye protection, hand protection, foot protection etc.) at all times during installation.
  - Make sure all safety precautions have been taken.
  - Always check and replace any part of vehicle that is worn or broken before starting install.
  - Do not mix anything EVO with weaker alternatives.
  - It is generally a good idea to apply liquid threadlock to all bolts.
  - Tighten included hardware to torque specifications in bottom table unless it is otherwise specified, factory bolts should be torqued to factory Jeep specifications.
- 





1. Place one side of EVO MFG side upright flush onto top of truck bedside, make sure the EVO cutout side of the upright is on top and facing out.



2. Maneuver lower bracketry of upright where horizontal bend is flush on top of bedside and vertical bend is flush with inside of bedside.
- 



3. Insert M8 washer onto all M8 bolts. With washer on bolt, bolt bed rack upright onto the side of truck bed in the 4 holes located below the top lip of the bed (as pictured) Tighten but do not torque.



Only install one side at this time.

---



4. Assemble all cross members onto the installed upright.
5. Use the supplied hardware to loosely secure each crossmember to the upright at the three hole locations (pictured).

Make sure cross members are installed underneath top bend of upright. (Use picture for reference)

---



6. Insert the opposite upright where the horizontal bend at the bottom of upright sits on top of bedside and lower vertical bend is flush with inside of bedside. (pictured)
  7. Attach top side of upright into crossmembers (crossmembers seated below top bend of upright) Use picture for reference.
- 



8. Insert M8 bolts and install into the 4 bolt holes below top lip of bedside.
  9. Install hardware into the three holes in each crossmember to marry the crossmembers to the upright.
- 





10. With all bolts loosely installed, manipulate the rack until best fit is obtained.
11. Torque all hardware using specified table on last page. M8 bolts torqued to 18 ft/lbs



After Install:

- Tighten all bolts securing purchased parts to specified locations.
- After completing installation using provided instructions, go through all steps again to make sure nothing was missed, not tightened or improperly assembled.
- Some components may need to be purchased separately.
- Check turn signals, headlights, fog lights (if applicable), taillights, blinkers and windshield wipers.
- Adjust mirrors, speedometer and headlights if needed.
- Make sure all gauges are fully operational.
- Drive the vehicle slowly for a couple minutes, looking and listening for abnormal noises while driving. After modification of a vehicle there will be differences in driving experiences and capabilities, be mindful of that.
- Inspect and Retorque all Bolts after 500 miles of completed installation and regularly thereafter.
- Some modification may be required.



Recommended Torque:

Size	Grade 2		Grade 5		Grade 8		18-8 S/S	
	Coarse	Fine	Coarse	Fine	Coarse	Fine	Coarse	Fine
<b>#4*</b>	-	-	-	-	-	-	5.2	-
<b>#6*</b>	-	-	-	-	-	-	9.6	-
<b>#8*</b>	-	-	-	-	-	-	19.8	-
<b>#10*</b>	-	-	-	-	-	-	22.8	31.7
<b>1/4</b>	4	4.7	6.3	7.3	9	10	6.3	7.8
<b>5/16</b>	8	9	13	14	18	20	11	11.8
<b>3/8</b>	15	17	23	26	33	37	20	22
<b>7/16</b>	24	27	37	41	52	58	31	33
<b>1/2</b>	37	41	57	64	80	90	43	45
<b>9/16</b>	53	59	82	91	115	129	57	63
<b>5/8</b>	73	83	112	128	159	180	93	104
<b>3/4</b>	125	138	200	223	282	315	128	124
<b>7/8</b>	129	144	322	355	454	501	194	193
<b>1+</b>	188	210	483	541	682	764	287	289



EVO Manufacturing  
Jeep Wrangler JT Gladiator 2019+  
Gladiator Bed Rack Instruction Manual  
EVO- 3073/B, EVO- 3074/B





Before starting installation procedure please read <http://evomfg.com>Returns-Warranties-Shipping>

---

**CAREFULLY READ AND FOLLOW ALL INSTRUCTIONS IN THIS MANUAL AND KEEP FOR FUTURE REFERENCE. IF YOU HAVE ANY QUESTIONS ABOUT THE PRODUCT CALL EVO MANUFACTURING. FAILURE TO FOLLOW GUIDELINES COULD RESULT IN MALFUNCTION OF PARTS OR INJURY. PLEASE HAVE A TRAINED PROFESSIONAL ASSIST WITH OR INSTALL ALL PRODUCTS. INSTALLING EVO MFG PRODUCTS OR KITS DEMANDS SPECIFIC KNOWLEDGE, TOOLS AND EXPERIENCE. GENERAL KNOWLEDGE OF HOW TO USE LATER SPECIFIED TOOLS AND/OR LIMITED EXPERIENCE WITH EVO MFG PRODUCTS MAY NOT BE ENOUGH TO PROPERLY COMPLETE THESE TASKS. SOME OF EVO MFG PRODUCTS MAY REQUIRE TWO OR MORE PEOPLE TO INSTALL SAFELY AND CORRECTLY. DO NOT ATTEMPT ALONE, ALWAYS ENLIST THE HELP OF TRAINED PROFESSIONAL WHEN NEEDED.**

**Notes: Set Up Before installation**

**Make sure to clean top of bed sides and below bed lip.**

**May require 2 persons to ease install.**

**Keep all mounting bolts loose (installed but not torqued) we will torque later at the end of complete installation, after all bolts are loosely installed.**

**READ BEFORE INSTALL:**

It is generally a good idea to apply Loctite to all threaded bolts.

ALWAYS wear safety glasses and other approved safety gear when working on a vehicle.

All supplied bolts torqued according to chart at end of instruction.

It is recommended all installation be performed by a trained professional. Some modification may have to be done.

It is advised to not carry items at high speeds that can create lift (upward force to due to wind)



Parts included: Table below shows black (painted) Gladiator Bed Rack.

Description	#	Part #	Quantity
Driver Side Upright	1	EVO-12411	1
Crossmembers	2	EVO-12413	1
Hardware	3	EVO-770087	1
Passenger Side Upright	4	EVO-12415	1

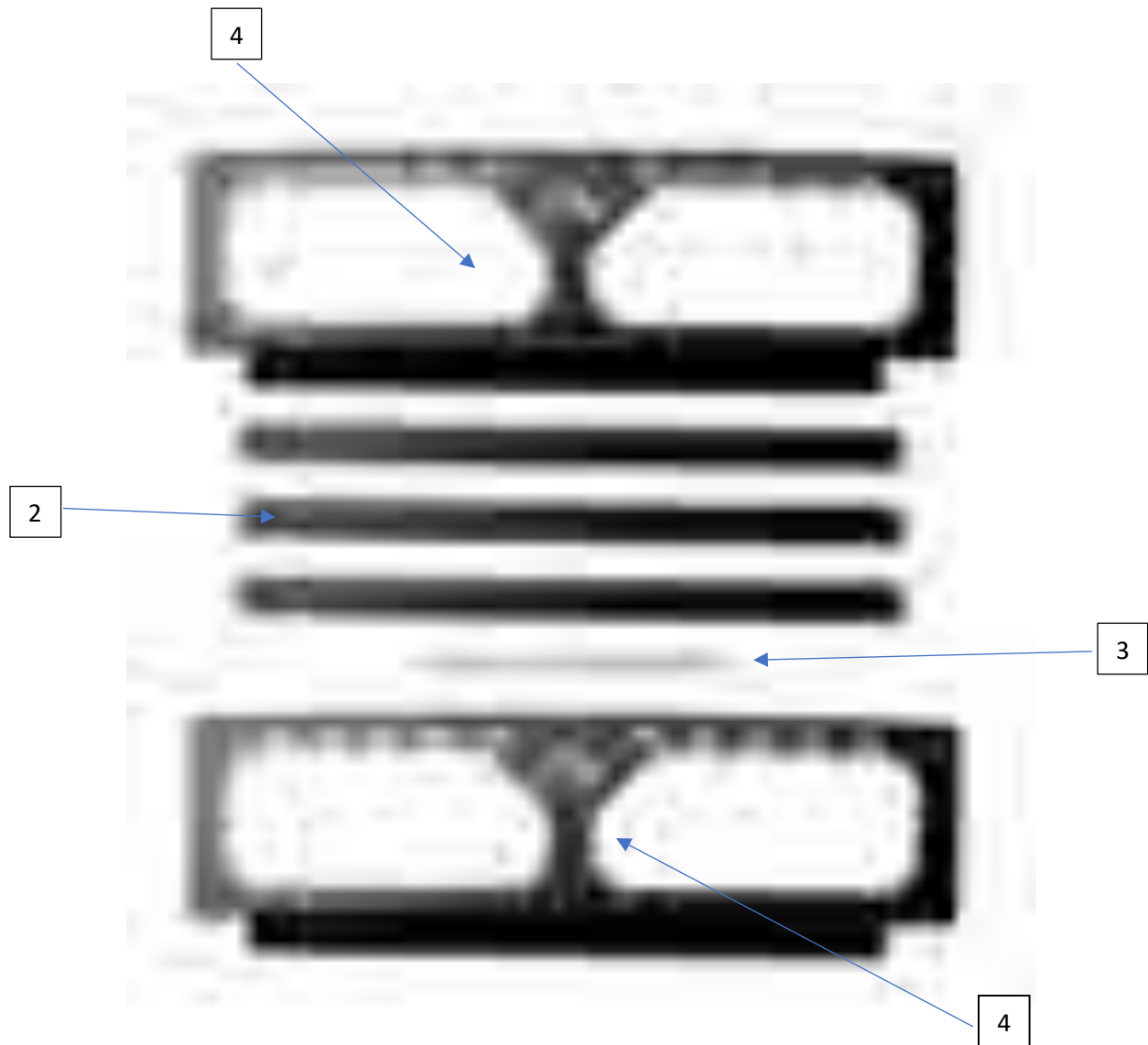

**Note:** Leave all hardware installed loosely until end of installation.





#### **Recommended Tools:**

- Loctite
  - Standard Wrench Set
- 



#### **Safety Steps for installation**

- For installing EVO MFG products always use wheel chokes to block rear tires from rolling.
  - Always make sure you have everything necessary ready before install.
  - If you have to, carefully lift front of vehicle by front frame rails extending suspension until tires leave the ground, place frame on approved jack stands for vehicle. Verify all lines/wires are not over extended.
  - Remove tires if needed for easier install.
  - Make sure to wear safety equipment (eye protection, hand protection, foot protection etc.) at all times during installation.
  - Make sure all safety precautions have been taken.
  - Always check and replace any part of vehicle that is worn or broken before starting install.
  - Do not mix anything EVO with weaker alternatives.
  - It is generally a good idea to apply liquid threadlock to all bolts.
  - Tighten included hardware to torque specifications in bottom table unless it is otherwise specified, factory bolts should be torqued to factory Jeep specifications.
- 





1. Place one side of EVO MFG side upright flush onto top of truck bedside, make sure the EVO cutout side of the upright is on top and facing out.



2. Maneuver lower bracketry of upright where horizontal bend is flush on top of bedside and vertical bend is flush with inside of bedside.
- 



3. Insert M8 washer onto all M8 bolts. With washer on bolt, bolt bed rack upright onto the side of truck bed in the 4 holes located below the top lip of the bed (as pictured) Tighten but do not torque.



Only install one side at this time.

---



4. Assemble all cross members onto the installed upright.
5. Use the supplied hardware to loosely secure each crossmember to the upright at the three hole locations (pictured).

Make sure cross members are installed underneath top bend of upright. (Use picture for reference)

---



6. Insert the opposite upright where the horizontal bend at the bottom of upright sits on top of bedside and lower vertical bend is flush with inside of bedside. (pictured)
  7. Attach top side of upright into crossmembers (crossmembers seated below top bend of upright) Use picture for reference.
- 



8. Insert M8 bolts and install into the 4 bolt holes below top lip of bedside.
  9. Install hardware into the three holes in each crossmember to marry the crossmembers to the upright.
- 





10. With all bolts loosely installed, manipulate the rack until best fit is obtained.
11. Torque all hardware using specified table on last page. M8 bolts torqued to 18 ft/lbs



After Install:

- Tighten all bolts securing purchased parts to specified locations.
- After completing installation using provided instructions, go through all steps again to make sure nothing was missed, not tightened or improperly assembled.
- Some components may need to be purchased separately.
- Check turn signals, headlights, fog lights (if applicable), taillights, blinkers and windshield wipers.
- Adjust mirrors, speedometer and headlights if needed.
- Make sure all gauges are fully operational.
- Drive the vehicle slowly for a couple minutes, looking and listening for abnormal noises while driving. After modification of a vehicle there will be differences in driving experiences and capabilities, be mindful of that.
- Inspect and Retorque all Bolts after 500 miles of completed installation and regularly thereafter.
- Some modification may be required.



Recommended Torque:

Size	Grade 2		Grade 5		Grade 8		18-8 S/S	
	Coarse	Fine	Coarse	Fine	Coarse	Fine	Coarse	Fine
#4*	-	-	-	-	-	-	5.2	-
#6*	-	-	-	-	-	-	9.6	-
#8*	-	-	-	-	-	-	19.8	-
#10*	-	-	-	-	-	-	22.8	31.7
1/4	4	4.7	6.3	7.3	9	10	6.3	7.8
5/16	8	9	13	14	18	20	11	11.8
3/8	15	17	23	26	33	37	20	22
7/16	24	27	37	41	52	58	31	33
1/2	37	41	57	64	80	90	43	45
9/16	53	59	82	91	115	129	57	63
5/8	73	83	112	128	159	180	93	104
3/4	125	138	200	223	282	315	128	124
7/8	129	144	322	355	454	501	194	193
1+	188	210	483	541	682	764	287	289



EVO Manufacturing  
Jeep Wrangler JT Gladiator 2019+  
Gladiator Bed Rack Instruction Manual  
EVO- 3073/B, EVO- 3074/B





Before starting installation procedure please read <http://evomfg.com>Returns-Warranties-Shipping>

---

**CAREFULLY READ AND FOLLOW ALL INSTRUCTIONS IN THIS MANUAL AND KEEP FOR FUTURE REFERENCE. IF YOU HAVE ANY QUESTIONS ABOUT THE PRODUCT CALL EVO MANUFACTURING. FAILURE TO FOLLOW GUIDELINES COULD RESULT IN MALFUNCTION OF PARTS OR INJURY. PLEASE HAVE A TRAINED PROFESSIONAL ASSIST WITH OR INSTALL ALL PRODUCTS. INSTALLING EVO MFG PRODUCTS OR KITS DEMANDS SPECIFIC KNOWLEDGE, TOOLS AND EXPERIENCE. GENERAL KNOWLEDGE OF HOW TO USE LATER SPECIFIED TOOLS AND/OR LIMITED EXPERIENCE WITH EVO MFG PRODUCTS MAY NOT BE ENOUGH TO PROPERLY COMPLETE THESE TASKS. SOME OF EVO MFG PRODUCTS MAY REQUIRE TWO OR MORE PEOPLE TO INSTALL SAFELY AND CORRECTLY. DO NOT ATTEMPT ALONE, ALWAYS ENLIST THE HELP OF TRAINED PROFESSIONAL WHEN NEEDED.**

**Notes: Set Up Before installation**

**Make sure to clean top of bed sides and below bed lip.**

**May require 2 persons to ease install.**

**Keep all mounting bolts loose (installed but not torqued) we will torque later at the end of complete installation, after all bolts are loosely installed.**

**READ BEFORE INSTALL:**

It is generally a good idea to apply Loctite to all threaded bolts.

ALWAYS wear safety glasses and other approved safety gear when working on a vehicle.

All supplied bolts torqued according to chart at end of instruction.

It is recommended all installation be performed by a trained professional. Some modification may have to be done.

It is advised to not carry items at high speeds that can create lift (upward force to due to wind)



Parts included: Table below shows black (painted) Gladiator Bed Rack.

Description	#	Part #	Quantity
Driver Side Upright	1	EVO-12411	1
Crossmembers	2	EVO-12413	1
Hardware	3	EVO-770087	1
Passenger Side Upright	4	EVO-12415	1

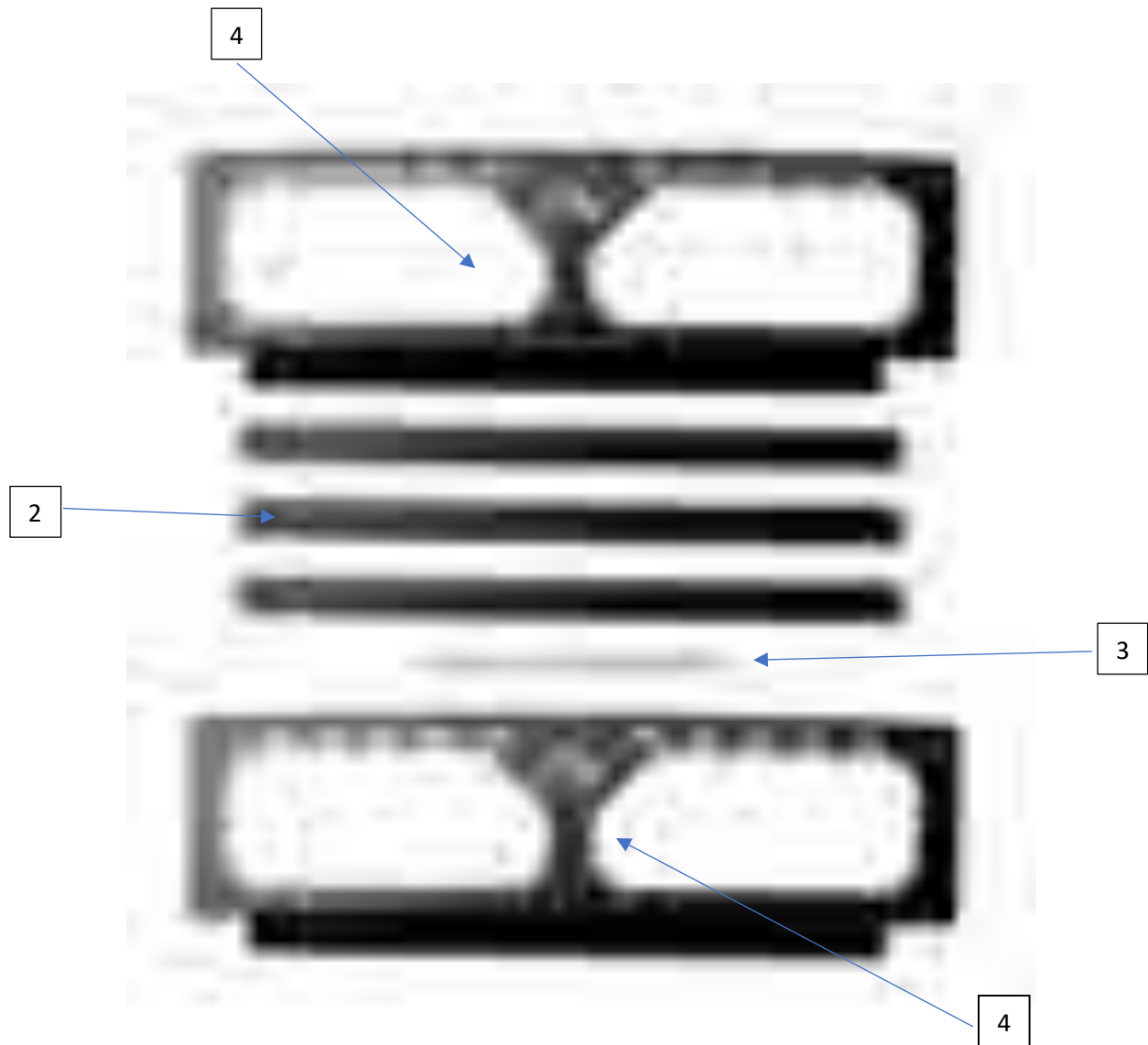

**Note:** Leave all hardware installed loosely until end of installation.





#### **Recommended Tools:**

- Loctite
  - Standard Wrench Set
- 



#### **Safety Steps for installation**

- For installing EVO MFG products always use wheel chokes to block rear tires from rolling.
  - Always make sure you have everything necessary ready before install.
  - If you have to, carefully lift front of vehicle by front frame rails extending suspension until tires leave the ground, place frame on approved jack stands for vehicle. Verify all lines/wires are not over extended.
  - Remove tires if needed for easier install.
  - Make sure to wear safety equipment (eye protection, hand protection, foot protection etc.) at all times during installation.
  - Make sure all safety precautions have been taken.
  - Always check and replace any part of vehicle that is worn or broken before starting install.
  - Do not mix anything EVO with weaker alternatives.
  - It is generally a good idea to apply liquid threadlock to all bolts.
  - Tighten included hardware to torque specifications in bottom table unless it is otherwise specified, factory bolts should be torqued to factory Jeep specifications.
- 





1. Place one side of EVO MFG side upright flush onto top of truck bedside, make sure the EVO cutout side of the upright is on top and facing out.



2. Maneuver lower bracketry of upright where horizontal bend is flush on top of bedside and vertical bend is flush with inside of bedside.
- 



3. Insert M8 washer onto all M8 bolts. With washer on bolt, bolt bed rack upright onto the side of truck bed in the 4 holes located below the top lip of the bed (as pictured) Tighten but do not torque.



Only install one side at this time.

---



4. Assemble all cross members onto the installed upright.
5. Use the supplied hardware to loosely secure each crossmember to the upright at the three hole locations (pictured).

Make sure cross members are installed underneath top bend of upright. (Use picture for reference)

---



6. Insert the opposite upright where the horizontal bend at the bottom of upright sits on top of bedside and lower vertical bend is flush with inside of bedside. (pictured)
  7. Attach top side of upright into crossmembers (crossmembers seated below top bend of upright) Use picture for reference.
- 



8. Insert M8 bolts and install into the 4 bolt holes below top lip of bedside.
  9. Install hardware into the three holes in each crossmember to marry the crossmembers to the upright.
- 





10. With all bolts loosely installed, manipulate the rack until best fit is obtained.
11. Torque all hardware using specified table on last page. M8 bolts torqued to 18 ft/lbs



After Install:

- Tighten all bolts securing purchased parts to specified locations.
- After completing installation using provided instructions, go through all steps again to make sure nothing was missed, not tightened or improperly assembled.
- Some components may need to be purchased separately.
- Check turn signals, headlights, fog lights (if applicable), taillights, blinkers and windshield wipers.
- Adjust mirrors, speedometer and headlights if needed.
- Make sure all gauges are fully operational.
- Drive the vehicle slowly for a couple minutes, looking and listening for abnormal noises while driving. After modification of a vehicle there will be differences in driving experiences and capabilities, be mindful of that.
- Inspect and Retorque all Bolts after 500 miles of completed installation and regularly thereafter.
- Some modification may be required.



Recommended Torque:

Size	Grade 2		Grade 5		Grade 8		18-8 S/S	
	Coarse	Fine	Coarse	Fine	Coarse	Fine	Coarse	Fine
<b>#4*</b>	-	-	-	-	-	-	5.2	-
<b>#6*</b>	-	-	-	-	-	-	9.6	-
<b>#8*</b>	-	-	-	-	-	-	19.8	-
<b>#10*</b>	-	-	-	-	-	-	22.8	31.7
<b>1/4</b>	4	4.7	6.3	7.3	9	10	6.3	7.8
<b>5/16</b>	8	9	13	14	18	20	11	11.8
<b>3/8</b>	15	17	23	26	33	37	20	22
<b>7/16</b>	24	27	37	41	52	58	31	33
<b>1/2</b>	37	41	57	64	80	90	43	45
<b>9/16</b>	53	59	82	91	115	129	57	63
<b>5/8</b>	73	83	112	128	159	180	93	104
<b>3/4</b>	125	138	200	223	282	315	128	124
<b>7/8</b>	129	144	322	355	454	501	194	193
<b>1+</b>	188	210	483	541	682	764	287	289



EVO Manufacturing  
Jeep Wrangler JT Gladiator 2019+  
Gladiator Bed Rack Instruction Manual  
EVO- 3073/B, EVO- 3074/B





Before starting installation procedure please read <http://evomfg.com>Returns-Warranties-Shipping>

---

**CAREFULLY READ AND FOLLOW ALL INSTRUCTIONS IN THIS MANUAL AND KEEP FOR FUTURE REFERENCE. IF YOU HAVE ANY QUESTIONS ABOUT THE PRODUCT CALL EVO MANUFACTURING. FAILURE TO FOLLOW GUIDELINES COULD RESULT IN MALFUNCTION OF PARTS OR INJURY. PLEASE HAVE A TRAINED PROFESSIONAL ASSIST WITH OR INSTALL ALL PRODUCTS. INSTALLING EVO MFG PRODUCTS OR KITS DEMANDS SPECIFIC KNOWLEDGE, TOOLS AND EXPERIENCE. GENERAL KNOWLEDGE OF HOW TO USE LATER SPECIFIED TOOLS AND/OR LIMITED EXPERIENCE WITH EVO MFG PRODUCTS MAY NOT BE ENOUGH TO PROPERLY COMPLETE THESE TASKS. SOME OF EVO MFG PRODUCTS MAY REQUIRE TWO OR MORE PEOPLE TO INSTALL SAFELY AND CORRECTLY. DO NOT ATTEMPT ALONE, ALWAYS ENLIST THE HELP OF TRAINED PROFESSIONAL WHEN NEEDED.**

**Notes: Set Up Before installation**

**Make sure to clean top of bed sides and below bed lip.**

**May require 2 persons to ease install.**

**Keep all mounting bolts loose (installed but not torqued) we will torque later at the end of complete installation, after all bolts are loosely installed.**

**READ BEFORE INSTALL:**

It is generally a good idea to apply Loctite to all threaded bolts.

ALWAYS wear safety glasses and other approved safety gear when working on a vehicle.

All supplied bolts torqued according to chart at end of instruction.

It is recommended all installation be performed by a trained professional. Some modification may have to be done.

It is advised to not carry items at high speeds that can create lift (upward force to due to wind)



Parts included: Table below shows black (painted) Gladiator Bed Rack.

Description	#	Part #	Quantity
Driver Side Upright	1	EVO-12411	1
Crossmembers	2	EVO-12413	1
Hardware	3	EVO-770087	1
Passenger Side Upright	4	EVO-12415	1

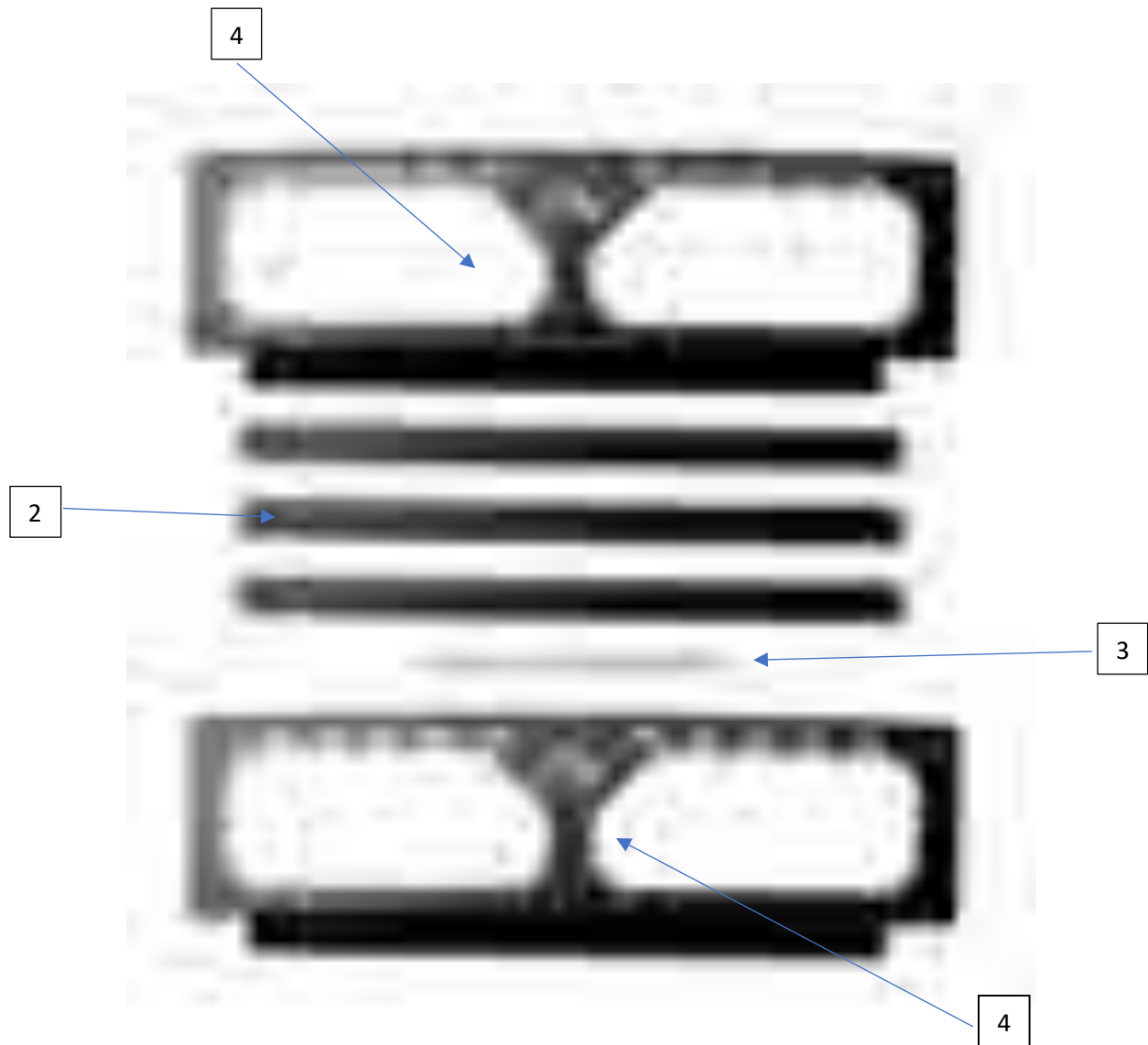

**Note:** Leave all hardware installed loosely until end of installation.





#### **Recommended Tools:**

- Loctite
  - Standard Wrench Set
- 



#### **Safety Steps for installation**

- For installing EVO MFG products always use wheel chokes to block rear tires from rolling.
  - Always make sure you have everything necessary ready before install.
  - If you have to, carefully lift front of vehicle by front frame rails extending suspension until tires leave the ground, place frame on approved jack stands for vehicle. Verify all lines/wires are not over extended.
  - Remove tires if needed for easier install.
  - Make sure to wear safety equipment (eye protection, hand protection, foot protection etc.) at all times during installation.
  - Make sure all safety precautions have been taken.
  - Always check and replace any part of vehicle that is worn or broken before starting install.
  - Do not mix anything EVO with weaker alternatives.
  - It is generally a good idea to apply liquid threadlock to all bolts.
  - Tighten included hardware to torque specifications in bottom table unless it is otherwise specified, factory bolts should be torqued to factory Jeep specifications.
- 





1. Place one side of EVO MFG side upright flush onto top of truck bedside, make sure the EVO cutout side of the upright is on top and facing out.



2. Maneuver lower bracketry of upright where horizontal bend is flush on top of bedside and vertical bend is flush with inside of bedside.
- 



3. Insert M8 washer onto all M8 bolts. With washer on bolt, bolt bed rack upright onto the side of truck bed in the 4 holes located below the top lip of the bed (as pictured) Tighten but do not torque.



Only install one side at this time.

---



4. Assemble all cross members onto the installed upright.
5. Use the supplied hardware to loosely secure each crossmember to the upright at the three hole locations (pictured).

Make sure cross members are installed underneath top bend of upright. (Use picture for reference)

---



6. Insert the opposite upright where the horizontal bend at the bottom of upright sits on top of bedside and lower vertical bend is flush with inside of bedside. (pictured)
  7. Attach top side of upright into crossmembers (crossmembers seated below top bend of upright) Use picture for reference.
- 



8. Insert M8 bolts and install into the 4 bolt holes below top lip of bedside.
  9. Install hardware into the three holes in each crossmember to marry the crossmembers to the upright.
- 





10. With all bolts loosely installed, manipulate the rack until best fit is obtained.
11. Torque all hardware using specified table on last page. M8 bolts torqued to 18 ft/lbs



After Install:

- Tighten all bolts securing purchased parts to specified locations.
- After completing installation using provided instructions, go through all steps again to make sure nothing was missed, not tightened or improperly assembled.
- Some components may need to be purchased separately.
- Check turn signals, headlights, fog lights (if applicable), taillights, blinkers and windshield wipers.
- Adjust mirrors, speedometer and headlights if needed.
- Make sure all gauges are fully operational.
- Drive the vehicle slowly for a couple minutes, looking and listening for abnormal noises while driving. After modification of a vehicle there will be differences in driving experiences and capabilities, be mindful of that.
- Inspect and Retorque all Bolts after 500 miles of completed installation and regularly thereafter.
- Some modification may be required.



Recommended Torque:

Size	Grade 2		Grade 5		Grade 8		18-8 S/S	
	Coarse	Fine	Coarse	Fine	Coarse	Fine	Coarse	Fine
#4*	-	-	-	-	-	-	5.2	-
#6*	-	-	-	-	-	-	9.6	-
#8*	-	-	-	-	-	-	19.8	-
#10*	-	-	-	-	-	-	22.8	31.7
1/4	4	4.7	6.3	7.3	9	10	6.3	7.8
5/16	8	9	13	14	18	20	11	11.8
3/8	15	17	23	26	33	37	20	22
7/16	24	27	37	41	52	58	31	33
1/2	37	41	57	64	80	90	43	45
9/16	53	59	82	91	115	129	57	63
5/8	73	83	112	128	159	180	93	104
3/4	125	138	200	223	282	315	128	124
7/8	129	144	322	355	454	501	194	193
1+	188	210	483	541	682	764	287	289



EVO Manufacturing  
Jeep Wrangler JT Gladiator  
JT Roof Rack  
EVO- 3075AL





Before starting installation procedure please read <http://evomfg.com>Returns-Warranties-Shipping>

---

**CAREFULLY READ AND FOLLOW ALL INSTRUCTIONS IN THIS MANUAL AND KEEP FOR FUTURE REFERENCE. IF YOU HAVE ANY QUESTIONS ABOUT THE PRODUCT CALL EVO MANUFACTURING. FAILURE TO FOLLOW GUIDELINES COULD RESULT IN MALFUNCTION OF PARTS OR INJURY. PLEASE HAVE A TRAINED PROFESSIONAL ASSIST WITH OR INSTALL ALL PRODUCTS. INSTALLING EVO MFG PRODUCTS OR KITS DEMANDS SPECIFIC KNOWLEDGE, TOOLS AND EXPERIENCE. GENERAL KNOWLEDGE OF HOW TO USE LATER SPECIFIED TOOLS AND/OR LIMITED EXPERIENCE WITH EVO MFG PRODUCTS MAY NOT BE ENOUGH TO PROPERLY COMPLETE THESE TASKS. SOME OF EVO MFG PRODUCTS MAY REQUIRE TWO OR MORE PEOPLE TO INSTALL SAFELY AND CORRECTLY. DO NOT ATTEMPT ALONE, ALWAYS ENLIST THE HELP OF TRAINED PROFESSIONAL WHEN NEEDED.**

**Notes: Set Up Before installation**

**Clean hard top and make sure water gutter is clean and clear of any debris.**

**Make sure to start with the standard unmodified hard top.**

**Knowledge of installing nutserts and install tool will be needed.**

**Keep all mounting bolts loose (installed but not torqued) we will torque later at the end of complete installation.**

**READ BEFORE INSTALL:**

It is generally a good idea to apply Loctite to all threaded bolts.

ALWAYS wear safety glasses and other approved safety gear when working on a vehicle.

All supplied bolts torqued according to chart at end of instruction.

It is recommended all installation be performed by a trained professional. Some modification may have to be done.

This rack has a distributed dynamic load rating of 100lbs/45kg. Applying a bead of RTV Silicone in drip rail before inserting rack rails is advised for higher loads/speeds. It is advised to not carry items at high speeds that can create lift (upward force to due to wind) such as but not limited to kayaks and surfboards etc.



Parts included: Table below shows JT Bare Aluminum Roof Rack.

Description	#	Part #	Quantity
Roof Rack Front Plate	1	EVO-12365AL	1
Driver Side Plate	2	EVO-12406AL	1
Passenger Side Plate	3	EVO-12407AL	1
Rear Plate	4	EVO-12408AL	1
Lower T Slats	5	EVO-12366AL	3
Upper L Slats	6	EVO-12367AL	4
Outer Mount Bracket Assemble	7	EVO-12368AL	4
Inner/Upper Main Mount	8	EVO-12369AL	4
Inner Bolt Tab	9	EVO-12370AL	4
Roof Rack Hardware	10	EVO-770085	1
HD Rubber Trim	11	EVO-900432	6
Under Lip Trim	12	EVO-900433	2
Zinc-Plated Rivet Nut	13	EVO-900415	4
HHCS 5/16-18 x 2.50 Gr8 Zinc	14	EVO-900166	4
SAE Washer 5/16 Zinc	15	EVO-900213	4







**Recommended Tools:**

- Allen set
  - Nutsert tool
  - Rubber Mallet
- 



Safety Steps for installation

- For installing EVO MFG products always use wheel chokes to block rear tires from rolling.
  - Always make sure you have everything necessary ready before install.
  - If you have to, carefully lift front of vehicle by front frame rails extending suspension until tires leave the ground, place frame on approved jack stands for vehicle. Verify all lines/wires are not over extended.
  - Remove tires if needed for easier install.
  - Make sure to wear safety equipment (eye protection, hand protection, foot protection etc.) at all times during installation.
  - Make sure all safety precautions have been taken.
  - Always check and replace any part of vehicle that is worn or broken before starting install.
  - Do not mix anything EVO with weaker alternatives.
  - It is generally a good idea to apply liquid threadlock to all bolts.
  - Tighten included hardware to torque specifications in bottom table unless it is otherwise specified, factory bolts should be torqued to factory Jeep specifications.
- 





## **INSTALL**

Begin by assembling the inner slat assembly. Each will consist of 2 "L" Slat pieces and 1 "T" slat pieces.

1. Using supplied  $\frac{1}{4}$ " bolt, washer and flange nuts, assemble the inner slat assembly by installing 2 bolts on the 2 inner holes of each. The end 2 holes on each end of each slat assembly should remain without bolts at this time.

**Tighten bolts of assembly.**





Assemble the front and rear slat assemblies next. These will consist of 1 "L" Slat piece and 1 "T" flat piece.

2. Using supplied  $\frac{1}{4}$ " bolt, washer and flange nuts, assemble 2 sets of end (front and rear) slat assemblies by installing bolts on the 3 inner holes only. The end 2 holes and other middle 3 holes should remain without bolts at this time.
3. Tighten 3 bolts on both front and rear assemblies. Front and rear assemblies are duplicates of each other.



**On a flat surface**

Loosely assemble the perimeter sections of the rack. This consists of the Driver side plate, Passenger side plate, Front plate and Rear plate.

4. Using the supplied  $\frac{1}{4}$ " bolts, washer and flange nut loosely install 2 sets at each corner.





5. Using supplied  $\frac{1}{4}$ " bolt, washer and flange nuts, loosely install the pre-assembled middle cross bar slat, front and rear cross bar slat.

All cross bar assemblies should be installed on the underside of the perimeter parts.

---



6. Using supplied  $\frac{5}{16}$ " bolt, washer, flange nut. Install upper bolt plate and lower bolt plate as shown. Install upper bolt plate from inside of main plate through slot toward the outside. Tighten bolts. Do this at all 4 ends.
- 



7. Using your nutsert installation tool and tool specific installation guide, install nutserts onto the outer rail mounting plate. Use picture as reference.
- 





8. Install edge trimming on the edge of the 4 outer rail mounting plate lips.



**Upper bolt plate should be installed to the inside of main side plate and pass through large slot. See picture to the right**





**This may require 2 or more people.**

9. With rack loosely assembled and upside down. Flip over if needed. Install/press on edge trim on driver side plate edge end to end. Trim and use remainder to repeat on passenger side plate.

10. Flip rack with top up. Lift over jeep hard top and set into place on into the drip rail. Rack should be placed where the rear edge of the side plates line up with the rear of the drip rail. Use line on picture as reference.



**The rack may require a slight push to fully seat into drip rail.**

---

11. Insert bolt and washer from top down of upper mounting plate and thread into outer rail mount. Lower edge with trim should be grabbing underside of hardtop drip rail.

**Note:** Do not over tighten this bolt. Snug to 15 lb/ft. Repeat on all 4 mounting ends.

---



**Tighten all bolts.**



After Install:

- Tighten all bolts securing purchased parts to specified locations.
- After completing installation using provided instructions, go through all steps again to make sure nothing was missed, not tightened or improperly assembled.
- Some components may need to be purchased separately.
- Check turn signals, headlights, fog lights (if applicable), taillights, blinkers and windshield wipers.
- Adjust mirrors, speedometer and headlights if needed.
- Make sure all gauges are fully operational.
- Drive the vehicle slowly for a couple minutes, looking and listening for abnormal noises while driving. After modification of a vehicle there will be differences in driving experiences and capabilities, be mindful of that.
- Inspect and Retorque all Bolts after 500 miles of completed installation and regularly thereafter.
- Some modification may be required.

Recommended Torque:

Size	Grade 2		Grade 5		Grade 8		18-8 S/S	
	Coarse	Fine	Coarse	Fine	Coarse	Fine	Coarse	Fine
<b>#4*</b>	-	-	-	-	-	-	5.2	-
<b>#6*</b>	-	-	-	-	-	-	9.6	-
<b>#8*</b>	-	-	-	-	-	-	19.8	-
<b>#10*</b>	-	-	-	-	-	-	22.8	31.7
<b>1/4</b>	4	4.7	6.3	7.3	9	10	6.3	7.8
<b>5/16</b>	8	9	13	14	18	20	11	11.8
<b>3/8</b>	15	17	23	26	33	37	20	22
<b>7/16</b>	24	27	37	41	52	58	31	33
<b>1/2</b>	37	41	57	64	80	90	43	45
<b>9/16</b>	53	59	82	91	115	129	57	63
<b>5/8</b>	73	83	112	128	159	180	93	104
<b>3/4</b>	125	138	200	223	282	315	128	124
<b>7/8</b>	129	144	322	355	454	501	194	193
<b>1†</b>	188	210	483	541	682	764	287	289



EVO Manufacturing

Jeep Wrangler JL/JT Gladiator

JL/JT Control Arms

EVO- 3082B, 3081B, 3007B, 3006B, 1175B, 1174B







Before starting installation procedure please read <http://evomfg.com>Returns-Warranties-Shipping>

**CAREFULLY READ AND FOLLOW ALL INSTRUCTIONS IN THIS MANUAL AND KEEP FOR FUTURE REFERENCE. IF YOU HAVE ANY QUESTIONS ABOUT THE PRODUCT CALL EVO MANUFACTURING. FAILURE TO FOLLOW GUIDELINES COULD RESULT IN MALFUNCTION OF PARTS OR INJURY. PLEASE HAVE A TRAINED PROFESSIONAL ASSIST WITH OR INSTALL ALL PRODUCTS. INSTALLING EVO MFG PRODUCTS OR KITS DEMANDS SPECIFIC KNOWLEDGE, TOOLS AND EXPERIENCE. GENERAL KNOWLEDGE OF HOW TO USE LATER SPECIFIED TOOLS AND/OR LIMITED EXPERIENCE WITH EVO MFG PRODUCTS MAY NOT BE ENOUGH TO PROPERLY COMPLETE THESE TASKS. SOME OF EVO MFG PRODUCTS MAY REQUIRE TWO OR MORE PEOPLE TO INSTALL SAFELY AND CORRECTLY. DO NOT ATTEMPT ALONE, ALWAYS ENLIST THE HELP OF TRAINED PROFESSIONAL WHEN NEEDED.**

**Notes: Set Up Before installation**

**This is a general instruction for this component kit.**

**Directions/pictures may vary for each specific install, use for reference only.**

**Keep all mounting bolts loose (installed but not torqued) we will torque later at the end of complete installation**

**Do not remove more than two control arms at a time**

**FRONT LOWER JL ENFORCER ARM STARTING LEGNTH CENTER TO CENTER, 24 1/8"**

**FRONT UPPER JL ENFORCER ARM STARTING LEGNTH CENTER TO CENTER, 20 1/4"**

**REAR LOWER JL ENFORCER ARM STARTING LEGNTH CENTER TO CENTER, 19 3/4"**

**REAR UPPER JL ENFORCER ARM STARTING LEGNTH CENTER TO CENTER, 17 1/2"**

**READ BEFORE INSTALL:**

ALL measurements stated above are starting points only, every vehicle is different. Professional alignment is recommended.

It is generally a good idea to apply Loctite to all threaded bolts.

ALWAYS wear safety glasses and other approved safety gear when working on a vehicle.

All supplied bolts torqued according to chart at end of instruction.

It is recommended all installation be performed by a trained professional. Some modification may have to be done.

Paint all unfinished surfaces after install is complete.



Parts included: Table below shows JL/JT Control Arms.

Description	#	Part #	Quantity
Jl Rear Lower Adj Control Arms	1	1174B	2
JL Rear Upper Adj Control Arms	2	1175B	2
JL/JT Front Lower Control Arms	3	3006B	2
JL/JT Front Upper Control Arms	4	3007B	2
JT Rear Adj Upper Control Arms	5	3081B	2
JT Rear Adj Lower Control Arms	6	3082B	2

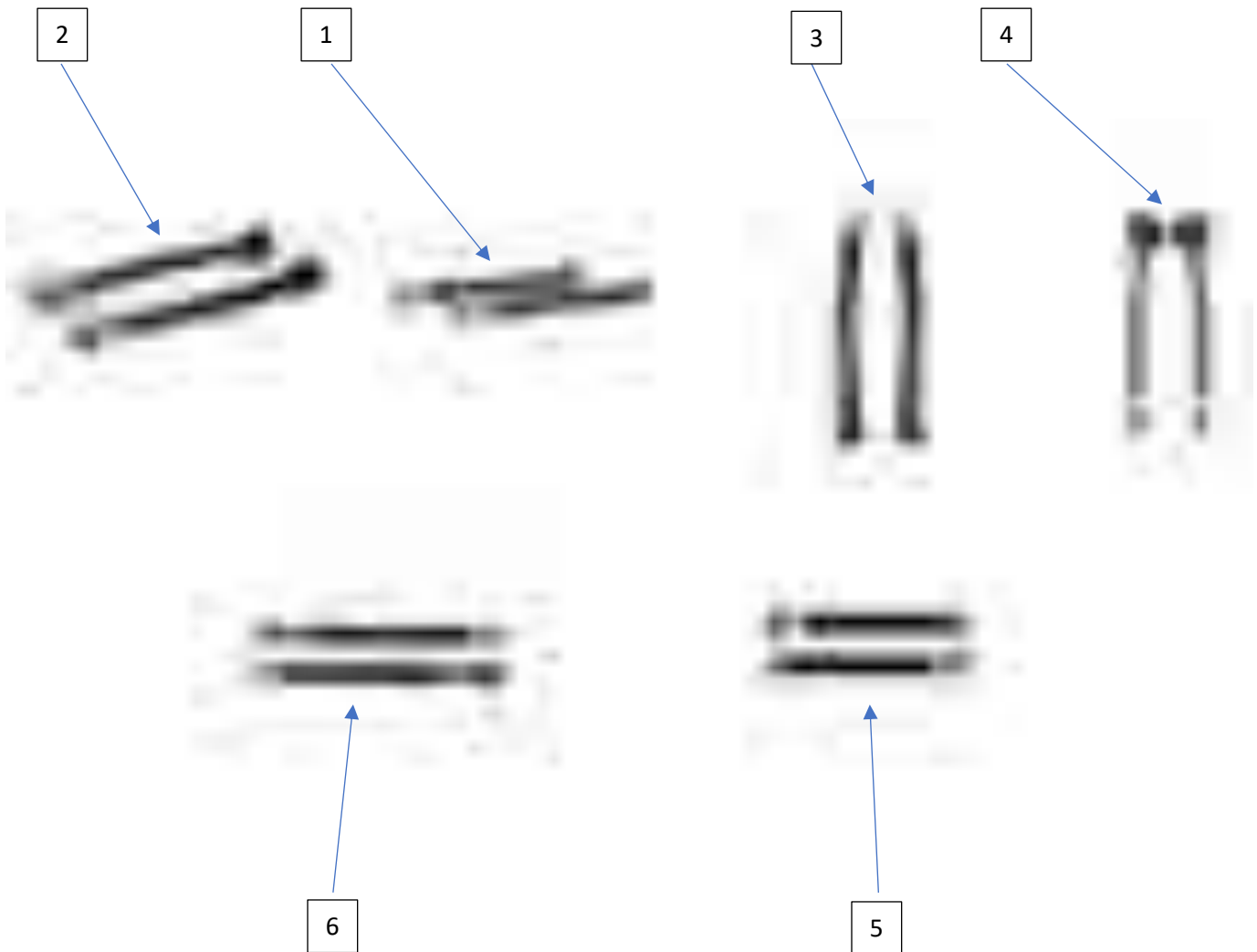



#### **Recommended Tools:**

- Standard socket set w/ wrench
  - OR Standard wrench set
- 



#### **Safety Steps for installation**

- For installing EVO MFG products always use wheel chokes to block rear tires from rolling.
  - Always make sure you have everything necessary ready before install.
  - If you have to, carefully lift front of vehicle by front frame rails extending suspension until tires leave the ground, place frame on approved jack stands for vehicle. Verify all lines/wires are not over extended.
  - Remove tires if needed for easier install.
  - Make sure to wear safety equipment (eye protection, hand protection, foot protection etc.) at all times during installation.
  - Make sure all safety precautions have been taken.
  - Always check and replace any part of vehicle that is worn or broken before starting install.
  - Do not mix anything EVO with weaker alternatives.
  - It is generally a good idea to apply liquid threadlock to all bolts.
  - Tighten included hardware to torque specifications in bottom table unless it is otherwise specified, factory bolts should be torqued to factory Jeep specifications.
- 





**After alignment is complete and no additional adjustments are to be made to control arms. Torque all 1" Jam Nuts to 250 ft/lbs and all 1-1/4" Jam Nuts torque to 300 ft/lbs. Regularly check all jam nuts and punch bolts on all control arms for proper torque/tightness. Failure to do so may cause premature wear of threads on arms.**

For front upper control arms:

1. Disconnect push-in clip from front upper control arm mounts at axle holding wire.

For all other arms:

2. Remove and replace one arm at a time. Keep bolts loose (installed but un-torqued) as described above. We will torque later in the installation process.

Use pictures as reference.



3. Make sure zerk fittings are facing up and at adjustable end at axle.
4. Adjustable end of control arms should be on the axle side.
5. Reuse factory hardware to mount EVO MFG control arms.

Note: For front upper control arms, bend in arm should face down.

Use pictures as reference.





Set pinion angle on vehicle so that the driveshaft and the pinion are inline with the axle at an approximate right height and centered to vehicle.

---



---

#### After Install:

- Tighten all bolts securing purchased parts to specified locations.
- After completing installation using provided instructions, go through all steps again to make sure nothing was missed, not tightened or improperly assembled.
- Some components may need to be purchased separately.
- Check turn signals, headlights, fog lights (if applicable), taillights, blinkers and windshield wipers.
- Adjust mirrors, speedometer and headlights if needed.
- Make sure all gauges are fully operational.
- Drive the vehicle slowly for a couple minutes, looking and listening for abnormal noises while driving. After modification of a vehicle there will be differences in driving experiences and capabilities, be mindful of that.
- Inspect and Retorque all Bolts after 500 miles of completed installation and regularly thereafter.
- Some modification may be required.



Recommended Torque:

Size	Grade 2		Grade 5		Grade 8		18-8 S/S	
	Coarse	Fine	Coarse	Fine	Coarse	Fine	Coarse	Fine
<b>#4*</b>	-	-	-	-	-	-	5.2	-
<b>#6*</b>	-	-	-	-	-	-	9.6	-
<b>#8*</b>	-	-	-	-	-	-	19.8	-
<b>#10*</b>	-	-	-	-	-	-	22.8	31.7
<b>1/4</b>	4	4.7	6.3	7.3	9	10	6.3	7.8
<b>5/16</b>	8	9	13	14	18	20	11	11.8
<b>3/8</b>	15	17	23	26	33	37	20	22
<b>7/16</b>	24	27	37	41	52	58	31	33
<b>1/2</b>	37	41	57	64	80	90	43	45
<b>9/16</b>	53	59	82	91	115	129	57	63
<b>5/8</b>	73	83	112	128	159	180	93	104
<b>3/4</b>	125	138	200	223	282	315	128	124
<b>7/8</b>	129	144	322	355	454	501	194	193
<b>1†</b>	188	210	483	541	682	764	287	289



EVO Manufacturing

Jeep Wrangler JL/JT Gladiator

JL/JT Control Arms

EVO- 3082B, 3081B, 3007B, 3006B, 1175B, 1174B





Before starting installation procedure please read <http://evomfg.com>Returns-Warranties-Shipping>

**CAREFULLY READ AND FOLLOW ALL INSTRUCTIONS IN THIS MANUAL AND KEEP FOR FUTURE REFERENCE. IF YOU HAVE ANY QUESTIONS ABOUT THE PRODUCT CALL EVO MANUFACTURING. FAILURE TO FOLLOW GUIDELINES COULD RESULT IN MALFUNCTION OF PARTS OR INJURY. PLEASE HAVE A TRAINED PROFESSIONAL ASSIST WITH OR INSTALL ALL PRODUCTS. INSTALLING EVO MFG PRODUCTS OR KITS DEMANDS SPECIFIC KNOWLEDGE, TOOLS AND EXPERIENCE. GENERAL KNOWLEDGE OF HOW TO USE LATER SPECIFIED TOOLS AND/OR LIMITED EXPERIENCE WITH EVO MFG PRODUCTS MAY NOT BE ENOUGH TO PROPERLY COMPLETE THESE TASKS. SOME OF EVO MFG PRODUCTS MAY REQUIRE TWO OR MORE PEOPLE TO INSTALL SAFELY AND CORRECTLY. DO NOT ATTEMPT ALONE, ALWAYS ENLIST THE HELP OF TRAINED PROFESSIONAL WHEN NEEDED.**

**Notes: Set Up Before installation**

**This is a general instruction for this component kit.**

**Directions/pictures may vary for each specific install, use for reference only.**

**Keep all mounting bolts loose (installed but not torqued) we will torque later at the end of complete installation**

**Do not remove more than two control arms at a time**

**FRONT LOWER JL ENFORCER ARM STARTING LEGNTH CENTER TO CENTER, 24 1/8"**

**FRONT UPPER JL ENFORCER ARM STARTING LEGNTH CENTER TO CENTER, 20 1/4"**

**REAR LOWER JL ENFORCER ARM STARTING LEGNTH CENTER TO CENTER, 19 3/4"**

**REAR UPPER JL ENFORCER ARM STARTING LEGNTH CENTER TO CENTER, 17 1/2"**

**READ BEFORE INSTALL:**

ALL measurements stated above are starting points only, every vehicle is different. Professional alignment is recommended.

It is generally a good idea to apply Loctite to all threaded bolts.

ALWAYS wear safety glasses and other approved safety gear when working on a vehicle.

All supplied bolts torqued according to chart at end of instruction.

It is recommended all installation be performed by a trained professional. Some modification may have to be done.

Paint all unfinished surfaces after install is complete.





Parts included: Table below shows JL/JT Control Arms.

Description	#	Part #	Quantity
Jl Rear Lower Adj Control Arms	1	1174B	2
JL Rear Upper Adj Control Arms	2	1175B	2
JL/JT Front Lower Control Arms	3	3006B	2
JL/JT Front Upper Control Arms	4	3007B	2
JT Rear Adj Upper Control Arms	5	3081B	2
JT Rear Adj Lower Control Arms	6	3082B	2

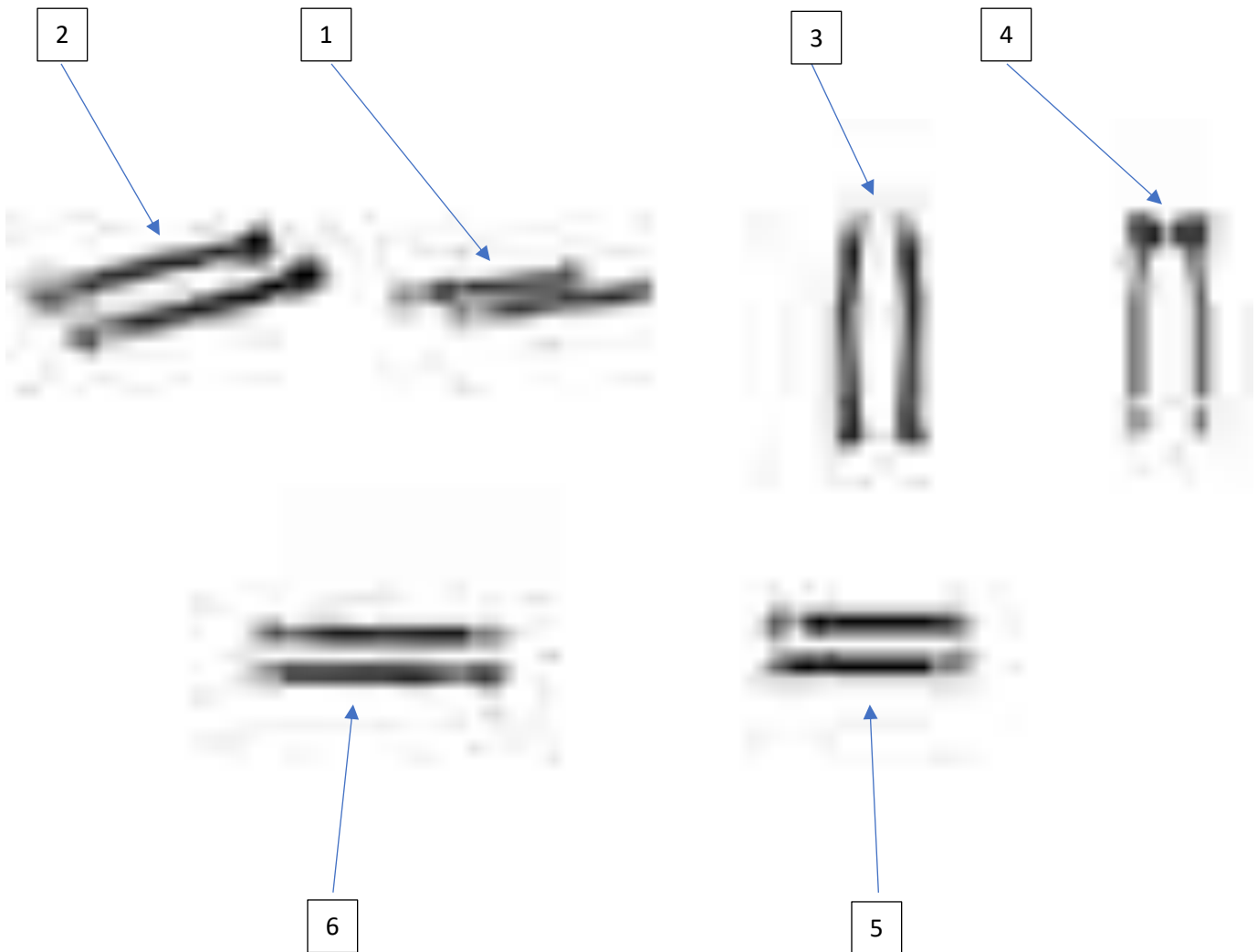



#### **Recommended Tools:**

- Standard socket set w/ wrench
  - OR Standard wrench set
- 



#### Safety Steps for installation

- For installing EVO MFG products always use wheel chokes to block rear tires from rolling.
  - Always make sure you have everything necessary ready before install.
  - If you have to, carefully lift front of vehicle by front frame rails extending suspension until tires leave the ground, place frame on approved jack stands for vehicle. Verify all lines/wires are not over extended.
  - Remove tires if needed for easier install.
  - Make sure to wear safety equipment (eye protection, hand protection, foot protection etc.) at all times during installation.
  - Make sure all safety precautions have been taken.
  - Always check and replace any part of vehicle that is worn or broken before starting install.
  - Do not mix anything EVO with weaker alternatives.
  - It is generally a good idea to apply liquid threadlock to all bolts.
  - Tighten included hardware to torque specifications in bottom table unless it is otherwise specified, factory bolts should be torqued to factory Jeep specifications.
- 





**After alignment is complete and no additional adjustments are to be made to control arms. Torque all 1" Jam Nuts to 250 ft/lbs and all 1-1/4" Jam Nuts torque to 300 ft/lbs. Regularly check all jam nuts and punch bolts on all control arms for proper torque/tightness. Failure to do so may cause premature wear of threads on arms.**

For front upper control arms:

1. Disconnect push-in clip from front upper control arm mounts at axle holding wire.

For all other arms:

2. Remove and replace one arm at a time. Keep bolts loose (installed but un-torqued) as described above. We will torque later in the installation process.

Use pictures as reference.



3. Make sure zerk fittings are facing up and at adjustable end at axle.
4. Adjustable end of control arms should be on the axle side.
5. Reuse factory hardware to mount EVO MFG control arms.

Note: For front upper control arms, bend in arm should face down.

Use pictures as reference.





Set pinion angle on vehicle so that the driveshaft and the pinion are inline with the axle at an approximate right height and centered to vehicle.

---



---

After Install:

- Tighten all bolts securing purchased parts to specified locations.
- After completing installation using provided instructions, go through all steps again to make sure nothing was missed, not tightened or improperly assembled.
- Some components may need to be purchased separately.
- Check turn signals, headlights, fog lights (if applicable), taillights, blinkers and windshield wipers.
- Adjust mirrors, speedometer and headlights if needed.
- Make sure all gauges are fully operational.
- Drive the vehicle slowly for a couple minutes, looking and listening for abnormal noises while driving. After modification of a vehicle there will be differences in driving experiences and capabilities, be mindful of that.
- Inspect and Retorque all Bolts after 500 miles of completed installation and regularly thereafter.
- Some modification may be required.



Recommended Torque:

Size	Grade 2		Grade 5		Grade 8		18-8 S/S	
	Coarse	Fine	Coarse	Fine	Coarse	Fine	Coarse	Fine
<b>#4*</b>	-	-	-	-	-	-	5.2	-
<b>#6*</b>	-	-	-	-	-	-	9.6	-
<b>#8*</b>	-	-	-	-	-	-	19.8	-
<b>#10*</b>	-	-	-	-	-	-	22.8	31.7
<b>1/4</b>	4	4.7	6.3	7.3	9	10	6.3	7.8
<b>5/16</b>	8	9	13	14	18	20	11	11.8
<b>3/8</b>	15	17	23	26	33	37	20	22
<b>7/16</b>	24	27	37	41	52	58	31	33
<b>1/2</b>	37	41	57	64	80	90	43	45
<b>9/16</b>	53	59	82	91	115	129	57	63
<b>5/8</b>	73	83	112	128	159	180	93	104
<b>3/4</b>	125	138	200	223	282	315	128	124
<b>7/8</b>	129	144	322	355	454	501	194	193
<b>1†</b>	188	210	483	541	682	764	287	289



EVO Manufacturing

Jeep Wrangler JL/JT Gladiator

JL/JT Control Arms

EVO- 3082B, 3081B, 3007B, 3006B, 1175B, 1174B





Before starting installation procedure please read <http://evomfg.com>Returns-Warranties-Shipping>

**CAREFULLY READ AND FOLLOW ALL INSTRUCTIONS IN THIS MANUAL AND KEEP FOR FUTURE REFERENCE. IF YOU HAVE ANY QUESTIONS ABOUT THE PRODUCT CALL EVO MANUFACTURING. FAILURE TO FOLLOW GUIDELINES COULD RESULT IN MALFUNCTION OF PARTS OR INJURY. PLEASE HAVE A TRAINED PROFESSIONAL ASSIST WITH OR INSTALL ALL PRODUCTS. INSTALLING EVO MFG PRODUCTS OR KITS DEMANDS SPECIFIC KNOWLEDGE, TOOLS AND EXPERIENCE. GENERAL KNOWLEDGE OF HOW TO USE LATER SPECIFIED TOOLS AND/OR LIMITED EXPERIENCE WITH EVO MFG PRODUCTS MAY NOT BE ENOUGH TO PROPERLY COMPLETE THESE TASKS. SOME OF EVO MFG PRODUCTS MAY REQUIRE TWO OR MORE PEOPLE TO INSTALL SAFELY AND CORRECTLY. DO NOT ATTEMPT ALONE, ALWAYS ENLIST THE HELP OF TRAINED PROFESSIONAL WHEN NEEDED.**

**Notes: Set Up Before installation**

**This is a general instruction for this component kit.**

**Directions/pictures may vary for each specific install, use for reference only.**

**Keep all mounting bolts loose (installed but not torqued) we will torque later at the end of complete installation.**

**Do not remove more than two control arms from vehicle at any time.**

**JL/JT FRONT LOWER ENFORCER ARM STARTING LEGNTH CENTER TO CENTER, 24 1/8"**

**JL/JT FRONT UPPER ENFORCER ARM STARTING LEGNTH CENTER TO CENTER, 20 1/4"**

**JL REAR LOWER ENFORCER ARM STARTING LEGNTH CENTER TO CENTER, 19 3/4"**

**JL REAR UPPER ENFORCER ARM STARTING LEGNTH CENTER TO CENTER, 17 1/2"**

**JT REAR LOWER ENFORCER ARM STARTING LEGNTH CENTER TO CENTER, 23 3/4"**

**JT REAR UPPER ENFORCER ARM STARTING LEGNTH CENTER TO CENTER, 16 5/8"**

**If installing ALL 8 Adjustable Control Arms, 3/8" can be added to all above measurements**

**READ BEFORE INSTALL:**

ALL measurements stated above are starting points only, every vehicle is different. Professional alignment is recommended.

It is generally a good idea to apply Loctite to all threaded bolts.

ALWAYS wear safety glasses and other approved safety gear when working on a vehicle.

All supplied bolts torqued according to chart at end of instruction.

It is recommended all installation be performed by a trained professional. Some modification may have to be done.

Paint all unfinished surfaces after install is complete.



GENERAL RULE: INSTALL THREADED ENDS AT AXLE. ZERK FITTINGS UP

Parts included: Table below shows JL/JT Control Arms.

Description	#	Part #	Quantity
JL Rear Lower Adj Control Arms	1	1174B	2
JL Rear Upper Adj Control Arms	2	1175B	2
JL/JT Front Lower Control Arms	3	3006B	2
JL/JT Front Upper Control Arms	4	3007B	2
JT Rear Adj Upper Control Arms	5	3081B	2
JT Rear Adj Lower Control Arms	6	3082B	2

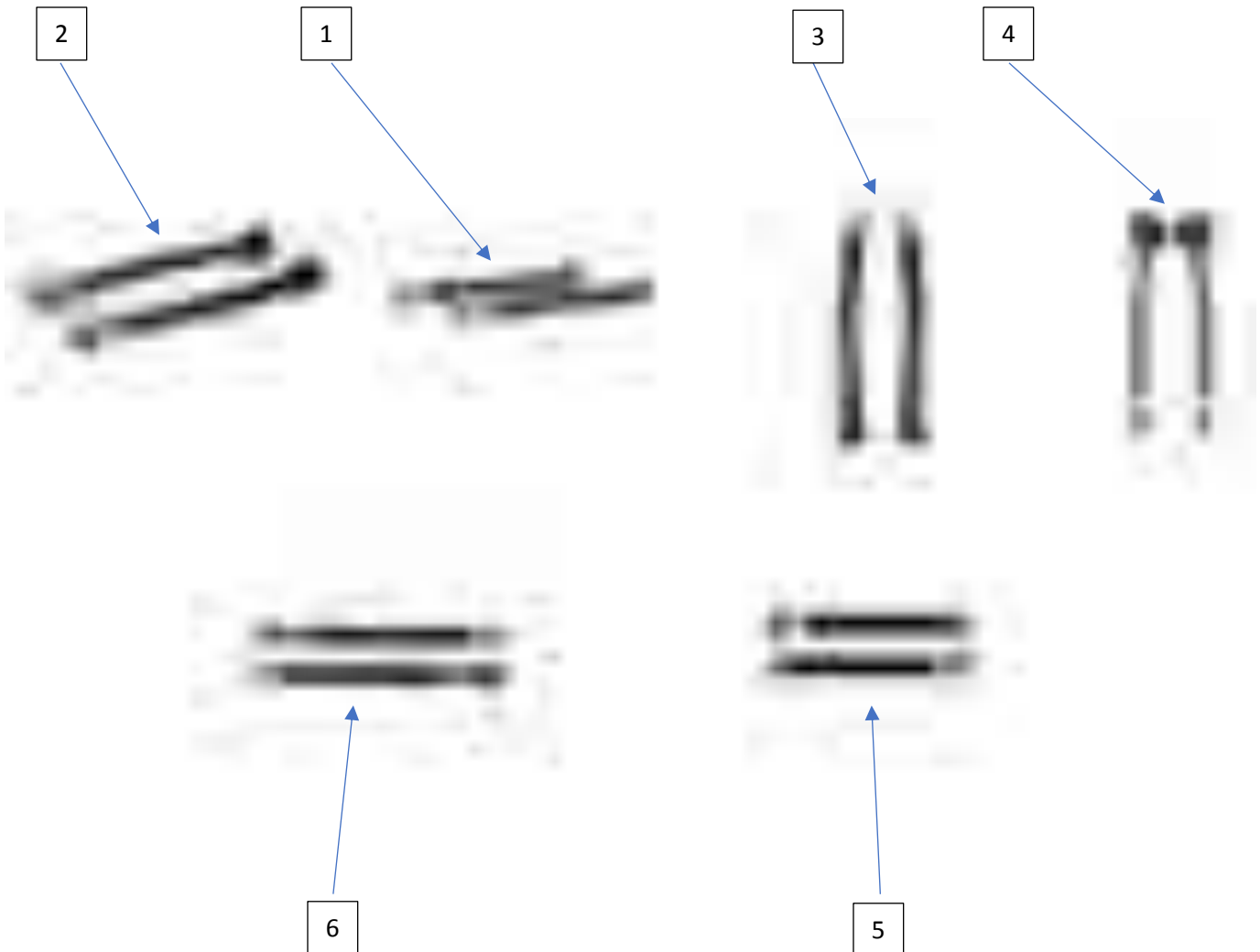





**Recommended Tools:**

- Standard socket set w/ wrench
- OR Standard wrench set



Safety Steps for installation

- For installing EVO MFG products always use wheel chokes to block rear tires from rolling.
- Always make sure you have everything necessary ready before install.
- If you have to, carefully lift front of vehicle by front frame rails extending suspension until tires leave the ground, place frame on approved jack stands for vehicle. Verify all lines/wires are not over extended.
- Remove tires if needed for easier install.
- Make sure to wear safety equipment (eye protection, hand protection, foot protection etc.) at all times during installation.
- Make sure all safety precautions have been taken.
- Always check and replace any part of vehicle that is worn or broken before starting install.
- Do not mix anything EVO with weaker alternatives.
- It is generally a good idea to apply liquid threadlock to all bolts.
- Tighten included hardware to torque specifications in bottom table unless it is otherwise specified, factory bolts should be torqued to factory Jeep specifications.





**After alignment is complete and no additional adjustments are to be made to control arms. Torque all 1" Jam Nuts to 250 ft/lbs and all 1-1/4" Jam Nuts torque to 300 ft/lbs. Regularly check all jam nuts and punch bolts on all control arms for proper torque/tightness. Failure to do so may cause premature wear of threads on arms.**

For front upper control arms:

1. Disconnect push-in clip from front upper control arm mounts at axle holding wire.

For all other arms:

2. Remove and replace one arm at a time. Keep bolts loose (installed but un-torqued) as described above. We will torque later in the installation process.

Use pictures as reference.



3. Make sure zerker fittings are facing up and at adjustable end at axle.
4. Adjustable end of control arms should be on the axle side.
5. Reuse factory hardware to mount EVO MFG control arms.

Note: For front upper control arms, bend in arm should face down.

Use pictures as reference.





Set pinion angle on vehicle so that the driveshaft and the pinion are inline with the axle at an approximate right height and centered to vehicle.

---



---

#### After Install:

- Tighten all bolts securing purchased parts to specified locations.
- After completing installation using provided instructions, go through all steps again to make sure nothing was missed, not tightened or improperly assembled.
- Some components may need to be purchased separately.
- Check turn signals, headlights, fog lights (if applicable), taillights, blinkers and windshield wipers.
- Adjust mirrors, speedometer and headlights if needed.
- Make sure all gauges are fully operational.
- Drive the vehicle slowly for a couple minutes, looking and listening for abnormal noises while driving. After modification of a vehicle there will be differences in driving experiences and capabilities, be mindful of that.
- Inspect and Retorque all Bolts after 500 miles of completed installation and regularly thereafter.
- Some modification may be required.



Recommended Torque:

Size	Grade 2		Grade 5		Grade 8		18-8 S/S	
	Coarse	Fine	Coarse	Fine	Coarse	Fine	Coarse	Fine
<b>#4*</b>	-	-	-	-	-	-	5.2	-
<b>#6*</b>	-	-	-	-	-	-	9.6	-
<b>#8*</b>	-	-	-	-	-	-	19.8	-
<b>#10*</b>	-	-	-	-	-	-	22.8	31.7
<b>1/4</b>	4	4.7	6.3	7.3	9	10	6.3	7.8
<b>5/16</b>	8	9	13	14	18	20	11	11.8
<b>3/8</b>	15	17	23	26	33	37	20	22
<b>7/16</b>	24	27	37	41	52	58	31	33
<b>1/2</b>	37	41	57	64	80	90	43	45
<b>9/16</b>	53	59	82	91	115	129	57	63
<b>5/8</b>	73	83	112	128	159	180	93	104
<b>3/4</b>	125	138	200	223	282	315	128	124
<b>7/8</b>	129	144	322	355	454	501	194	193
<b>1†</b>	188	210	483	541	682	764	287	289



EVO Manufacturing  
Jeep Wrangler JT Gladiator  
JT Rear Shock Extension  
EVO- 3083B





Before starting installation procedure please read <http://evomfg.com>Returns-Warranties-Shipping>

---

**CAREFULLY READ AND FOLLOW ALL INSTRUCTIONS IN THIS MANUAL AND KEEP FOR FUTURE REFERENCE. IF YOU HAVE ANY QUESTIONS ABOUT THE PRODUCT CALL EVO MANUFACTURING. FAILURE TO FOLLOW GUIDELINES COULD RESULT IN MALFUNCTION OF PARTS OR INJURY. PLEASE HAVE A TRAINED PROFESSIONAL ASSIST WITH OR INSTALL ALL PRODUCTS. INSTALLING EVO MFG PRODUCTS OR KITS DEMANDS SPECIFIC KNOWLEDGE, TOOLS AND EXPERIENCE. GENERAL KNOWLEDGE OF HOW TO USE LATER SPECIFIED TOOLS AND/OR LIMITED EXPERIENCE WITH EVO MFG PRODUCTS MAY NOT BE ENOUGH TO PROPERLY COMPLETE THESE TASKS. SOME OF EVO MFG PRODUCTS MAY REQUIRE TWO OR MORE PEOPLE TO INSTALL SAFELY AND CORRECTLY. DO NOT ATTEMPT ALONE, ALWAYS ENLIST THE HELP OF TRAINED PROFESSIONAL WHEN NEEDED.**

**Notes: Set Up Before installation**

**Keep all mounting bolts loose (installed but not torqued) we will torque later at the end of complete installation**

**Keep factory hardware for reuse**

**READ BEFORE INSTALL:**

It is generally a good idea to apply Loctite to all threaded bolts.

ALWAYS wear safety glasses and other approved safety gear when working on a vehicle.

All supplied bolts torqued according to chart at end of instruction.

It is recommended all installation be performed by a trained professional. Some modification may have to be done.

Paint all unfinished surfaces after install is complete.



Parts included: Table below shows black (painted) JT Rear Shock Extension.

Description	#	Part #	Quantity
JT rr Shock Extension Inner Plate	1	EVO-12425B	2
JT rr Shock Extension Outer Plate	2	EVO-12426B	2
Crush Tube	3	EVO-20038	2
Shock Extension Hardware	4	EVO-770088	1

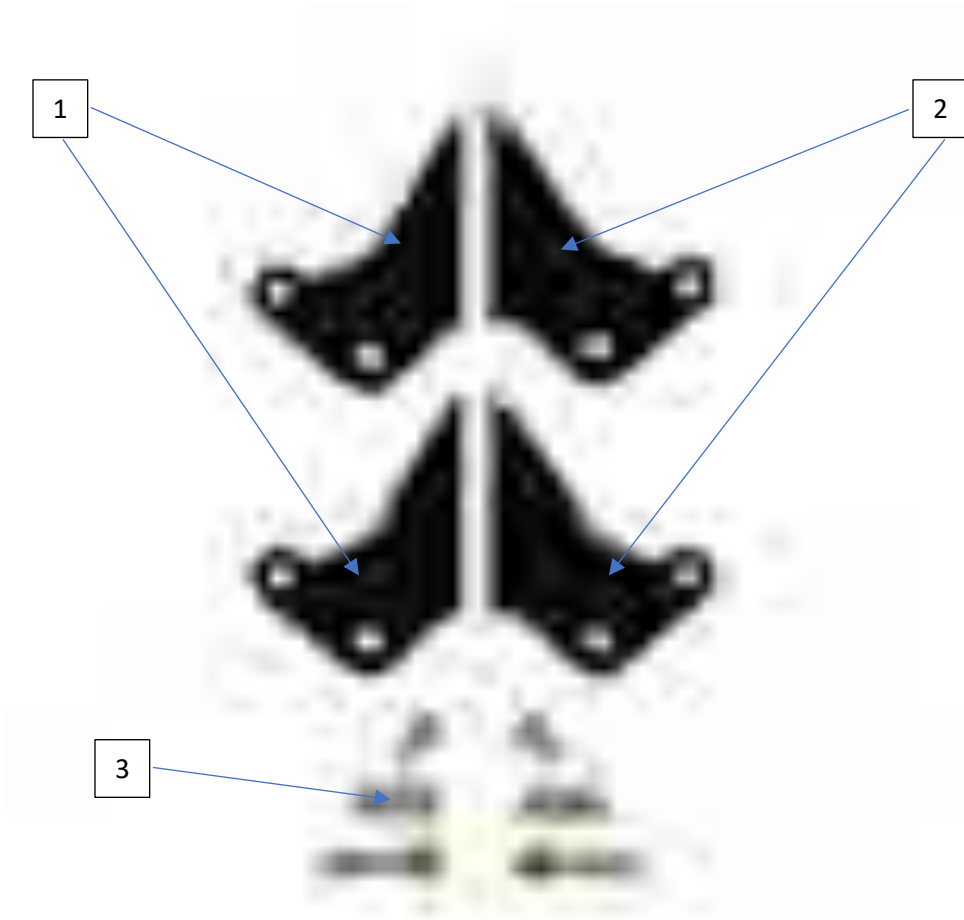



#### **Recommended Tools:**

- Standard sockets
  - Wrench set
- 



#### **Safety Steps for installation**

- For installing EVO MFG products always use wheel chokes to block rear tires from rolling.
  - Always make sure you have everything necessary ready before install.
  - If you have to, carefully lift front of vehicle by front frame rails extending suspension until tires leave the ground, place frame on approved jack stands for vehicle. Verify all lines/wires are not over extended.
  - Remove tires if needed for easier install.
  - Make sure to wear safety equipment (eye protection, hand protection, foot protection etc.) at all times during installation.
  - Make sure all safety precautions have been taken.
  - Always check and replace any part of vehicle that is worn or broken before starting install.
  - Do not mix anything EVO with weaker alternatives.
  - It is generally a good idea to apply liquid threadlock to all bolts.
  - Tighten included hardware to torque specifications in bottom table unless it is otherwise specified, factory bolts should be torqued to factory Jeep specifications.
- 







## **FRONT INSTALL**

After putting vehicle in park, on a flat surface, chalked the tires and turned off the vehicle.

1. Jack vehicle at axle, support axle with jack stands. Remove tires.
- 





2. Remove driver axle side shock mounting bolt then pivot shock out of the way. Repeat on passenger side.
- 

**Keep factory hardware**



Driver Side:

3. Place shock relocation bracket as shown on the driver side factory shock mounts. The smaller EVO MFG bracket is used on the inside of the factory shock mount. The larger EVO MFG Bracket is used on the outside of the factory shock bracket. Reference photo.
- 





Passenger Side:

4. Place shock relocation bracket as shown on the passenger side factory shock mounts. The smaller EVO MFG bracket is used on the inside of the factory shock mount. The larger EVO MFG Bracket is used on the outside of the factory shock bracket. Reference photo.
- 



5. Insert sleeve into original bolt location using supplied M14 bolts, washers, nut on both driver and passenger shock mounts. Loosely install at this time, do not tighten.
- 





6. Loosely install supplied washer on 3/8" bolt and insert from bottom to top of new assembly. Loosely install supplied nut, do not tighten. Reference picture. Repeat on opposite side.
- 



7. Use factory shock hardware to reinstall shocks into new higher shock location in EVO MFG bracket. Reference picture. Repeat on opposite side.
- 





## 8. Tighten all bolts to specified torque, lower vehicle.

### After Install:

- Tighten all bolts securing purchased parts to specified locations.
- After completing installation using provided instructions, go through all steps again to make sure nothing was missed, not tightened or improperly assembled.
- Some components may need to be purchased separately.
- Check turn signals, headlights, fog lights (if applicable), taillights, blinkers and windshield wipers.
- Adjust mirrors, speedometer and headlights if needed.
- Make sure all gauges are fully operational.
- Drive the vehicle slowly for a couple minutes, looking and listening for abnormal noises while driving. After modification of a vehicle there will be differences in driving experiences and capabilities, be mindful of that.
- Inspect and Retorque all Bolts after 500 miles of completed installation and regularly thereafter.
- Some modification may be required.

### Recommended Torque:

Size	Grade 2		Grade 5		Grade 8		18-8 S/S	
	Coarse	Fine	Coarse	Fine	Coarse	Fine	Coarse	Fine
<b>#4*</b>	-	-	-	-	-	-	5.2	-
<b>#6*</b>	-	-	-	-	-	-	9.6	-
<b>#8*</b>	-	-	-	-	-	-	19.8	-
<b>#10*</b>	-	-	-	-	-	-	22.8	31.7
<b>1/4</b>	4	4.7	6.3	7.3	9	10	6.3	7.8
<b>5/16</b>	8	9	13	14	18	20	11	11.8
<b>3/8</b>	15	17	23	26	33	37	20	22
<b>7/16</b>	24	27	37	41	52	58	31	33
<b>1/2</b>	37	41	57	64	80	90	43	45
<b>9/16</b>	53	59	82	91	115	129	57	63
<b>5/8</b>	73	83	112	128	159	180	93	104
<b>3/4</b>	125	138	200	223	282	315	128	124
<b>7/8</b>	129	144	322	355	454	501	194	193
<b>1†</b>	188	210	483	541	682	764	287	289



EVO Manufacturing

Jeep Wrangler JT Gladiator

JT Axle Swap Kit Instruction Manual

EVO- 3084



**This instruction is to be used as a general guide of assembly on various axles. Use original axle measurements for placement of bracketry, adjust for personal application. Radius openings on bracketry are 3.5" diameter, grinding can be done to adapt to others.**



Before starting installation procedure please read <http://evomfg.com>Returns-Warranties-Shipping>

**CAREFULLY READ AND FOLLOW ALL INSTRUCTIONS IN THIS MANUAL AND KEEP FOR FUTURE REFERENCE. IF YOU HAVE ANY QUESTIONS ABOUT THE PRODUCT CALL EVO MANUFACTURING. FAILURE TO FOLLOW GUIDELINES COULD RESULT IN MALFUNCTION OF PARTS OR INJURY. PLEASE HAVE A TRAINED PROFESSIONAL ASSIST WITH OR INSTALL ALL PRODUCTS. INSTALLING EVO MFG PRODUCTS OR KITS DEMANDS SPECIFIC KNOWLEDGE, TOOLS AND EXPERIENCE. GENERAL KNOWLEDGE OF HOW TO USE LATER SPECIFIED TOOLS AND/OR LIMITED EXPERIENCE WITH EVO MFG PRODUCTS MAY NOT BE ENOUGH TO PROPERLY COMPLETE THESE TASKS. SOME OF EVO MFG PRODUCTS MAY REQUIRE TWO OR MORE PEOPLE TO INSTALL SAFELY AND CORRECTLY. DO NOT ATTEMPT ALONE, ALWAYS ENLIST THE HELP OF TRAINED PROFESSIONAL WHEN NEEDED.**

**Notes: Set Up Before installation**

**This is a bracket kit for builders. This kit includes builder brackets and spring perches for axle conversions. This does not include parking brake cable provisions and/or other brake provisions as these vary per various axle manufacturers/original equipment. It's the owner's responsibility to adapt brake as needed and verify proper operation.**

**Cutting and grinding will be necessary for this installation.**

**Welding of brackets will be necessary**

**Make sure to clean axle.**

**May need to use a second person to ease install.**

**Keep all mounting bolts loose (installed but not torqued) we will torque later at the end of complete installation**

**READ BEFORE INSTALL:**

**It is the installers responsibility to adapt brake as needed and verify/confirm their proper operation. If you are not capable of this or any other procedure involved in this builders kit, do not proceed.**

It is generally a good idea to apply Loctite to all threaded bolts.

ALWAYS wear safety glasses and other approved safety gear when working on a vehicle.

All supplied bolts torqued according to chart at end of instruction.

It is recommended all installation be performed by a trained professional. Some modification may have to be done.

Paint all unfinished surfaces after install is complete.



Parts included: Table below shows Rear JT Gladiator Axle Swap Kit.

Description	#	Part #	Quantity
JT Rear Axle Rear Trackbar Bracket	1	EVO-12427	1
JT Rear Axle Forward Trackbar Bracket	2	EVO-12428	1
JT Rear Axle Trackbar Left Gusset	3	EVO-12429	1
JT Rear Axle Lower Arm/Sway Mount Passenger	4	EVO-12430	1
JT Rear Axle Lower Arm/Sway Mount Driver	5	EVO-12431	1
JT Rear Axle Outer Upper Arm Mount	6	EVO-12432	2
JT Rear Axle Inner Upper Arm Mount	7	EVO-12433	2
JT Rear Axle Upper Arm Gusset	8	EVO-12434	2
JT Rear Axle Swap Shock Mount	9	EVO-12435	4
JT Rear Axle Shock Mount Bracket Plate	10	EVO-12436	2
JT Rear Axle Main Spring Bump Mount Passenger	11	EVO-12437	1
JT Rear Axle Main Spring Bump Mount Driver	12	EVO-12438	1
JT Rear Axle Conversion Spring Tube	13	EVO-12439	2





**DRIVER SIDE**

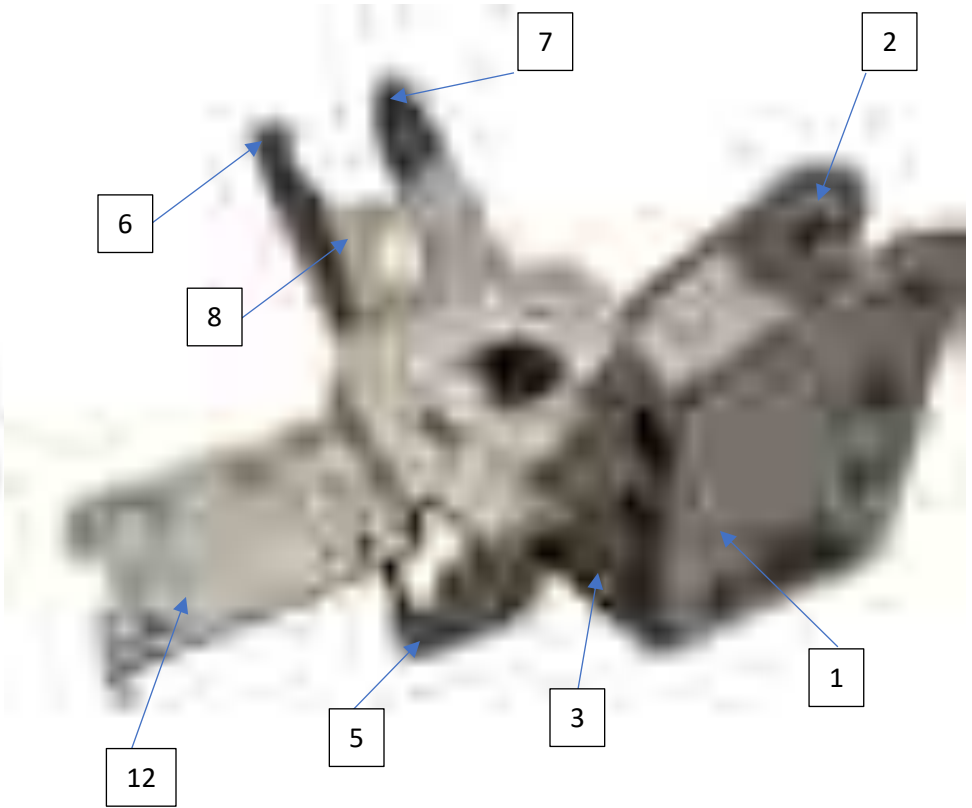
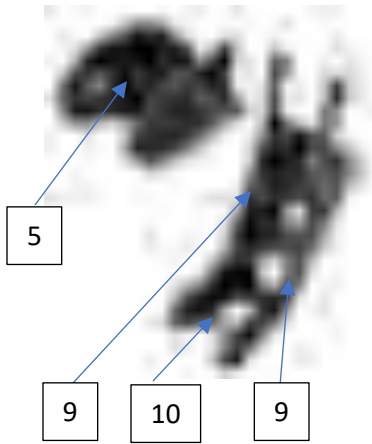

**PASSENGER SIDE**

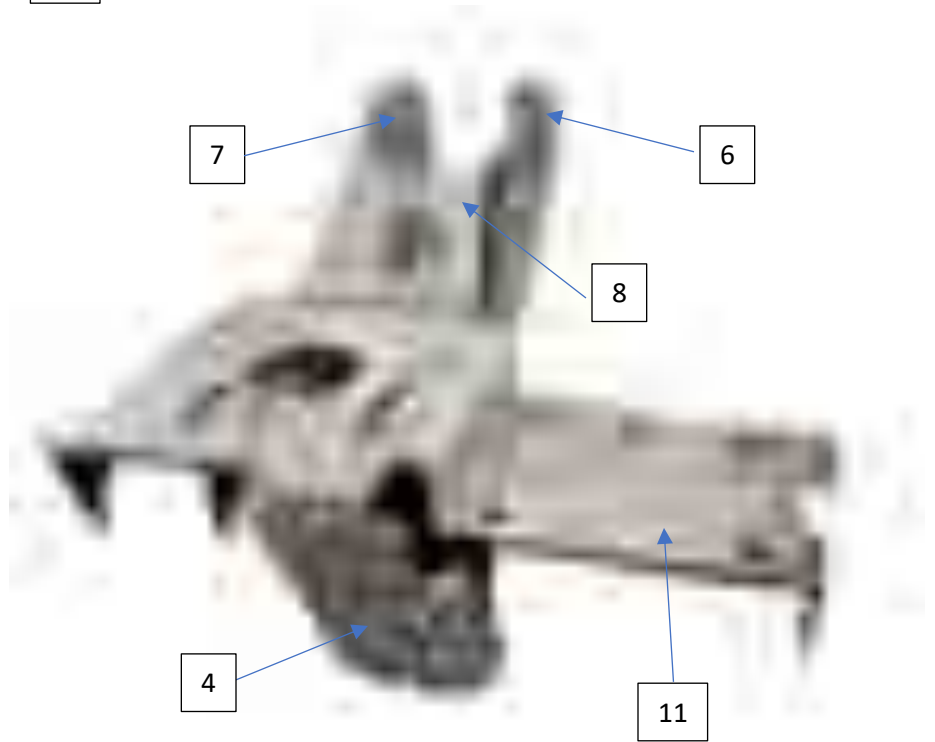
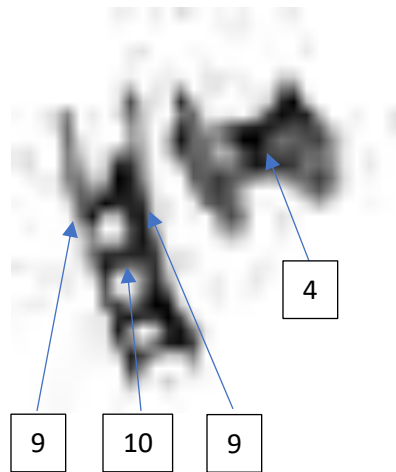



**Recommended Tools:**

- C clamps
  - Welder/ materials
  - Grinder
  - Torch/Plasma Cutter
  - Measuring tools
  - Angle Finder
- 



Safety Steps for installation

- For installing EVO MFG products always use wheel chokes to block rear tires from rolling.
  - Always make sure you have everything necessary ready before install.
  - If you have to, carefully lift front of vehicle by front frame rails extending suspension until tires leave the ground, place frame on approved jack stands for vehicle. Verify all lines/wires are not over extended.
  - Remove tires if needed for easier install.
  - Make sure to wear safety equipment (eye protection, hand protection, foot protection etc.) at all times during installation.
  - Make sure all safety precautions have been taken.
  - Always check and replace any part of vehicle that is worn or broken before starting install.
  - Do not mix anything EVO with weaker alternatives.
  - It is generally a good idea to apply liquid threadlock to all bolts.
  - Tighten included hardware to torque specifications in bottom table unless it is otherwise specified, factory bolts should be torqued to factory Jeep specifications.
- 





**Assemble:**

Putting left (driver) side together:

Place all brackets according to instruction steps onto prepped axle using factory geometry as a general guideline for placement.

Assemble brackets together.  
Reference picture/table above to make sure correct parts are fitted to the driver side bracket group. Use the following steps to assemble.

---

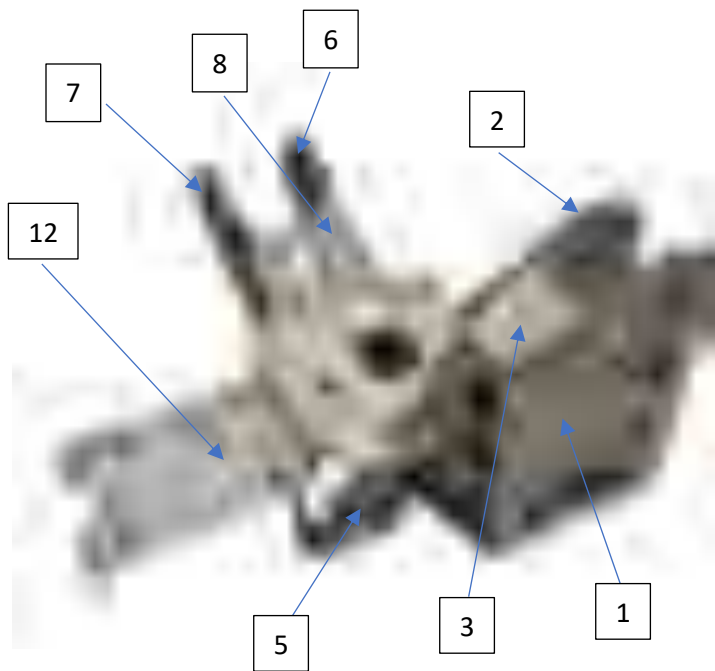



1. Start with placing the bump stop and coil spring bracket on the axle. We will connect the necessary brackets to the bump stop and coil bracket in the following steps.
- 

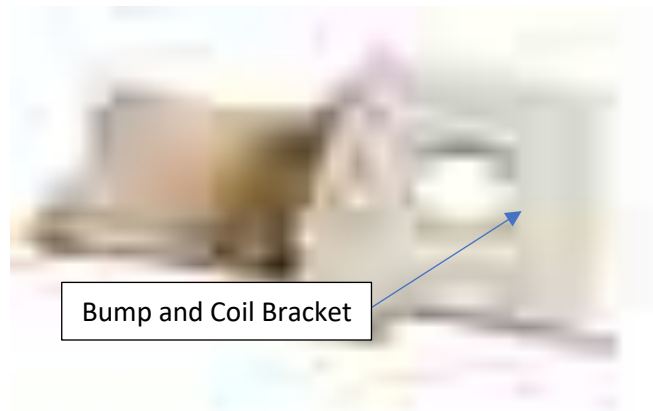

2. Now assemble the inner and outer upper arm mount onto the spring/bump stop bracket. The longer upper arm mount bracket should go on the inside and insert into the slot, the shorter bracket fit into the slot on the outside. Attach the upper arm mount gusset.
- 

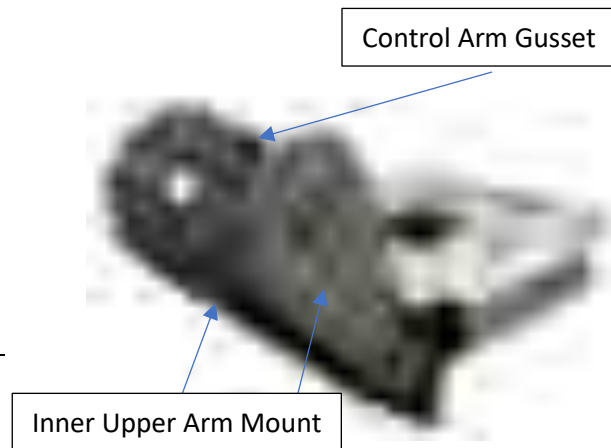

3. Place the inner and outer shock mount plate tabs into the slots complimenting the tab. Insert the two plates into the small slots on the main spring/bump stop bracket. Then on the bottom of the two shock mount brackets attach the shock mount gusset.
- 

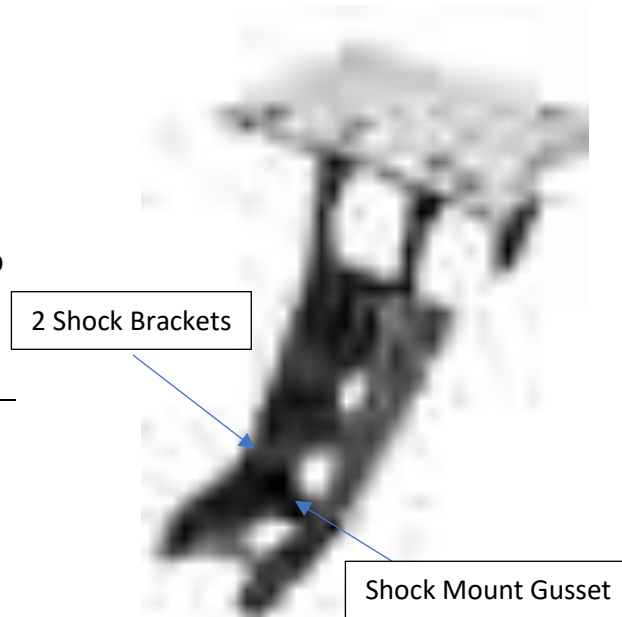



4. Take the lower control arm/sway bracket and install onto axle tube from bottom to top. You may have to pull open in order to fit around axle tube. Do not grind material. Then press back to tube diameter.
- 



5. Assemble the rear trackbar bracket, forward trackbar bracket and axle trackbar gusset as pictured. The forward bracket should be placed first. Then locate the gusset onto spring/bump bracket. Finally, lay rear bracket flush on the back side of the gusset.

Make sure the trackbar gusset seats in a similar position to the one in the picture. Use red line in picture for reference.

---

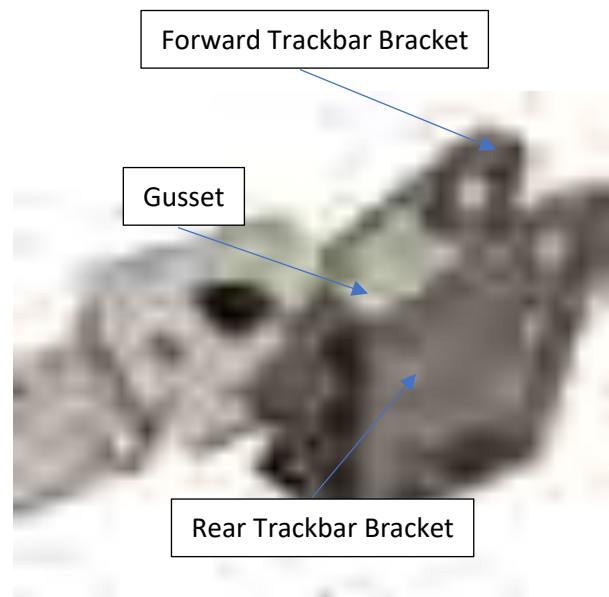



Putting left (passenger) side together:

Place all brackets according to instruction steps onto prepped axle using factory geometry as a general guideline for placement.

6. On a flat surface, assemble brackets together. Reference picture/table above to make sure correct parts are fitted to the passenger side bracket group.
- 

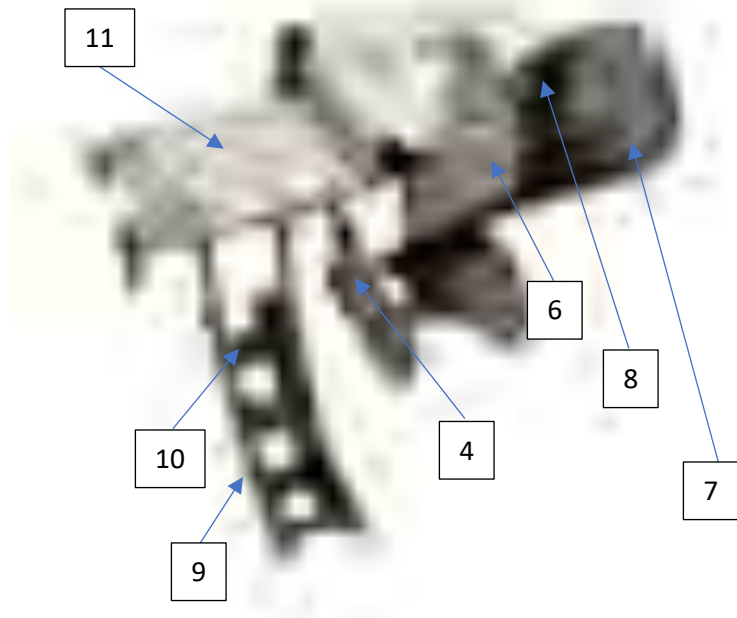

7. Start with placing the bump stop and coil spring bracket on the axle. We will connect the necessary brackets to the bump stop and coil bracket in the following steps.
- 

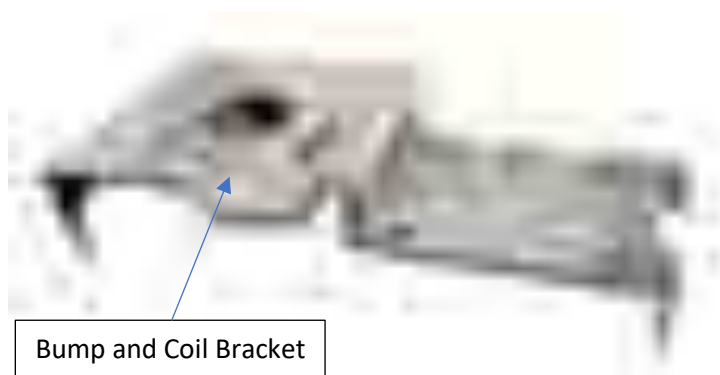



Now assemble the inner and outer upper arm mount onto the spring/bump stop bracket. The longer upper arm mount bracket should go on the inside and insert into the slot, the shorter bracket fit into the slot on the outside. Attach the upper arm mount gusset.

---

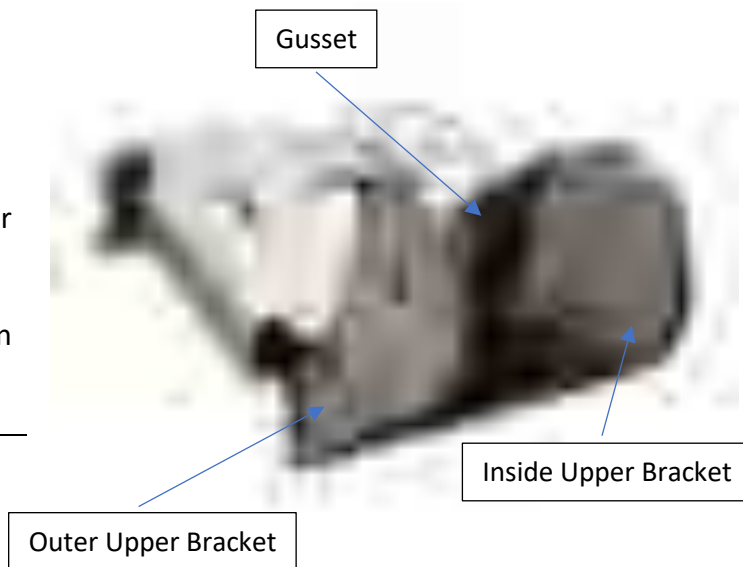

8. Place the inner and outer shock mount plate tabs into the slots complimenting the tab size. Insert the two plates into the small slots on the main spring/bump stop bracket. Then on the bottom of the two shock mount brackets attach the shock mount gusset.

---



9. Take the lower control arm/sway bar bracket and install onto axle tube from bottom to top. You may have to heat bracket and pull open in order to fit around axle tube. Do not grind material.
- 



10. Place the spring tube on top of both Bump/Spring brackets (one on each bracket). Locate the spring tube hole in bracket where spring will be placed, attach.
- 







After placing EVO MFG axle brackets on new axle, use C clamps to keep in place. Tack at multiple locations.

Every axle and setup is different, use factory axle as reference for placement of EVO MFG bracketry. Use picture as reference for a general idea on where brackets should be placed on axle. Adjust for your application.



Weld to axle.

---





After Install:

- Tighten all bolts securing all parts to specified locations.
- After completing installation using provided instructions, go through all steps again to make sure nothing was missed, not tightened or improperly assembled.
- Some components may need to be purchased separately.
- Check BRAKES, turn signals, headlights, fog lights (if applicable), taillights, blinkers and windshield wipers.
- Adjust mirrors, speedometer and headlights if needed.
- Make sure all gauges are fully operational.
- Before driving, check and make sure brakes are working properly, then drive the vehicle slowly for a couple minutes, looking and listening for abnormal noises while driving. After modification of a vehicle there will be differences in driving experiences and capabilities, be mindful of that.
- Inspect and Retorque all Bolts after 500 miles of completed installation and regularly thereafter.
- Some modification may be required.

Recommended Torque:

Size	Grade 2		Grade 5		Grade 8		18-8 S/S	
	Coarse	Fine	Coarse	Fine	Coarse	Fine	Coarse	Fine
<b>#4*</b>	-	-	-	-	-	-	5.2	-
<b>#6*</b>	-	-	-	-	-	-	9.6	-
<b>#8*</b>	-	-	-	-	-	-	19.8	-
<b>#10*</b>	-	-	-	-	-	-	22.8	31.7
<b>1/4</b>	4	4.7	6.3	7.3	9	10	6.3	7.8
<b>5/16</b>	8	9	13	14	18	20	11	11.8
<b>3/8</b>	15	17	23	26	33	37	20	22
<b>7/16</b>	24	27	37	41	52	58	31	33
<b>1/2</b>	37	41	57	64	80	90	43	45
<b>9/16</b>	53	59	82	91	115	129	57	63
<b>5/8</b>	73	83	112	128	159	180	93	104
<b>3/4</b>	125	138	200	223	282	315	128	124
<b>7/8</b>	129	144	322	355	454	501	194	193
<b>1†</b>	188	210	483	541	682	764	287	289



EVO Manufacturing

Jeep Wrangler JL/JLU and JT Gladiator

JL/JLU/JT Front Double Throwdown

EVO-3092B-S60

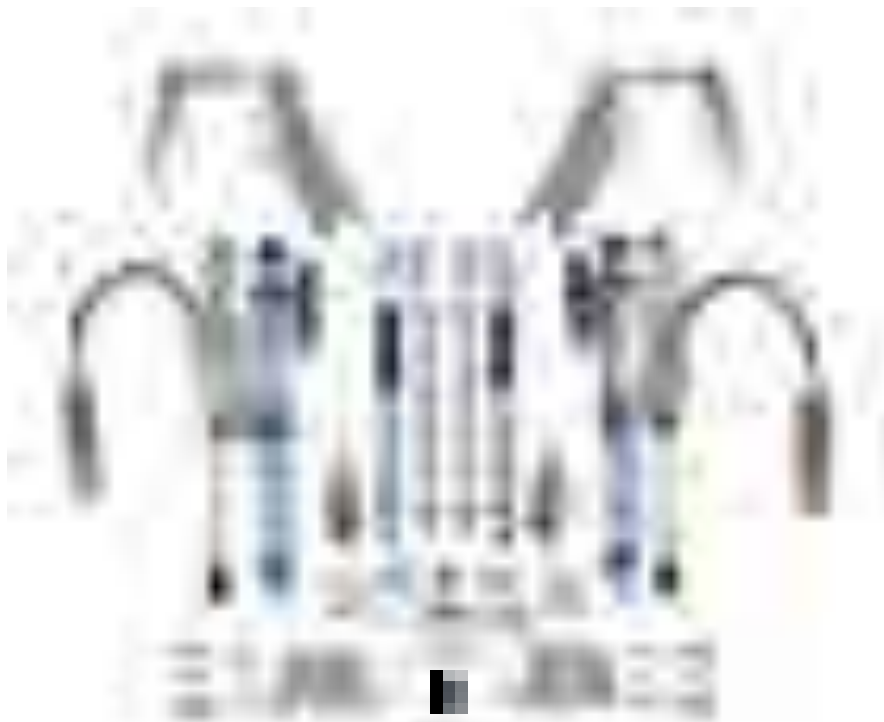



Before starting installation procedure please read <http://evomfg.com>Returns-Warranties-Shipping>

**CAREFULLY READ AND FOLLOW ALL INSTRUCTIONS IN THIS MANUAL AND KEEP FOR FUTURE REFERENCE. IF YOU HAVE ANY QUESTIONS ABOUT THE PRODUCT CALL EVO MANUFACTURING. FAILURE TO FOLLOW GUIDELINES COULD RESULT IN MALFUNCTION OF PARTS OR INJURY. PLEASE HAVE A TRAINED PROFESSIONAL ASSIST WITH OR INSTALL ALL PRODUCTS. INSTALLING EVO MFG PRODUCTS OR KITS DEMANDS SPECIFIC KNOWLEDGE, TOOLS AND EXPERIENCE. GENERAL KNOWLEDGE OF HOW TO USE LATER SPECIFIED TOOLS AND/OR LIMITED EXPERIENCE WITH EVO MFG PRODUCTS MAY NOT BE ENOUGH TO PROPERLY COMPLETE THESE TASKS. SOME OF EVO MFG PRODUCTS MAY REQUIRE TWO OR MORE PEOPLE TO INSTALL SAFELY AND CORRECTLY. DO NOT ATTEMPT ALONE, ALWAYS ENLIST THE HELP OF TRAINED PROFESSIONAL WHEN NEEDED.**

**Notes: Set Up Before installation**

**This kit requires drilling and cutting/grinding of both metal and plastic.**

**This kit also requires welding, disconnect all battery terminals before starting. Reinstall at end of installation**

**Kit requires 6 ft of 1" wide high temp wrap sleeving, you will have to purchase high temperature wrap sleeving separately from kit.**

**Wheel backspacing adjustments WILL be required.**

**EVO MFG recommends this installation be performed by a trained professional.**

**Always use approved safety gear/glasses and weight approved jack/jack stands.**

**Keep all mounting bolts loose (installed but not torqued) we will torque later at the end of complete installation**

**READ BEFORE INSTALL:**

Re-torque all bolts after first 100 miles High Clearance Fenders recommended \*Re-torque all bolts every 3000 miles and after every off-road use.

It is generally a good idea to apply liquid thread lock to all threaded bolts.

ALWAYS wear safety glasses and other approved safety gear when working on a vehicle.

All supplied bolts torqued according to chart at end of instruction.

It is recommended all installation be performed by a trained professional. Some modification may have to be done.

Paint all unfinished surfaces after install is complete.



Parts included: Table below shows Jeep Wrangler JL/Jeep Gladiator JT Double Throwdown.

Description	#	Quantity
Evo Spec 2.5" Front Coilover Pair	1	1
EVO Spec 3 Tube Bypass Pair	2	1
EVO Spec King 2.0 Air Bump	3	2
King 2.0 Air Bump Sleeve	4	2
Driver Steering Box Frame Plate	5	1
Pass Steering Box Frame Plate	6	1
Driver Double Throwdown Tower	7	1
Pass Double Throwdown Tower	8	1
Driver Aluminum Mesh	9	1
Passenger Aluminum Mesh	10	1
Coilover Reservoir Mount	11	2
Lower Reservoir Mount	12	2
Front Coilover Block Off Plate	13	2
Hardware Bag	14	1
Swaybar Poly Bushing	15	4
Swaybar Bushing Tube	16	4
Front Swaybay Link	17	2
Front Brakeline Pair	18	1
Axle Side Airbump Pad	19	2
Axle Side Shock Tabs	20	4
Shock Tie in Gusset	21	2
Driver Side Swaybar Bracket	22	1
Passenger Side Swaybar Bracket	23	1
Axle Side Hardware Bag	24	1

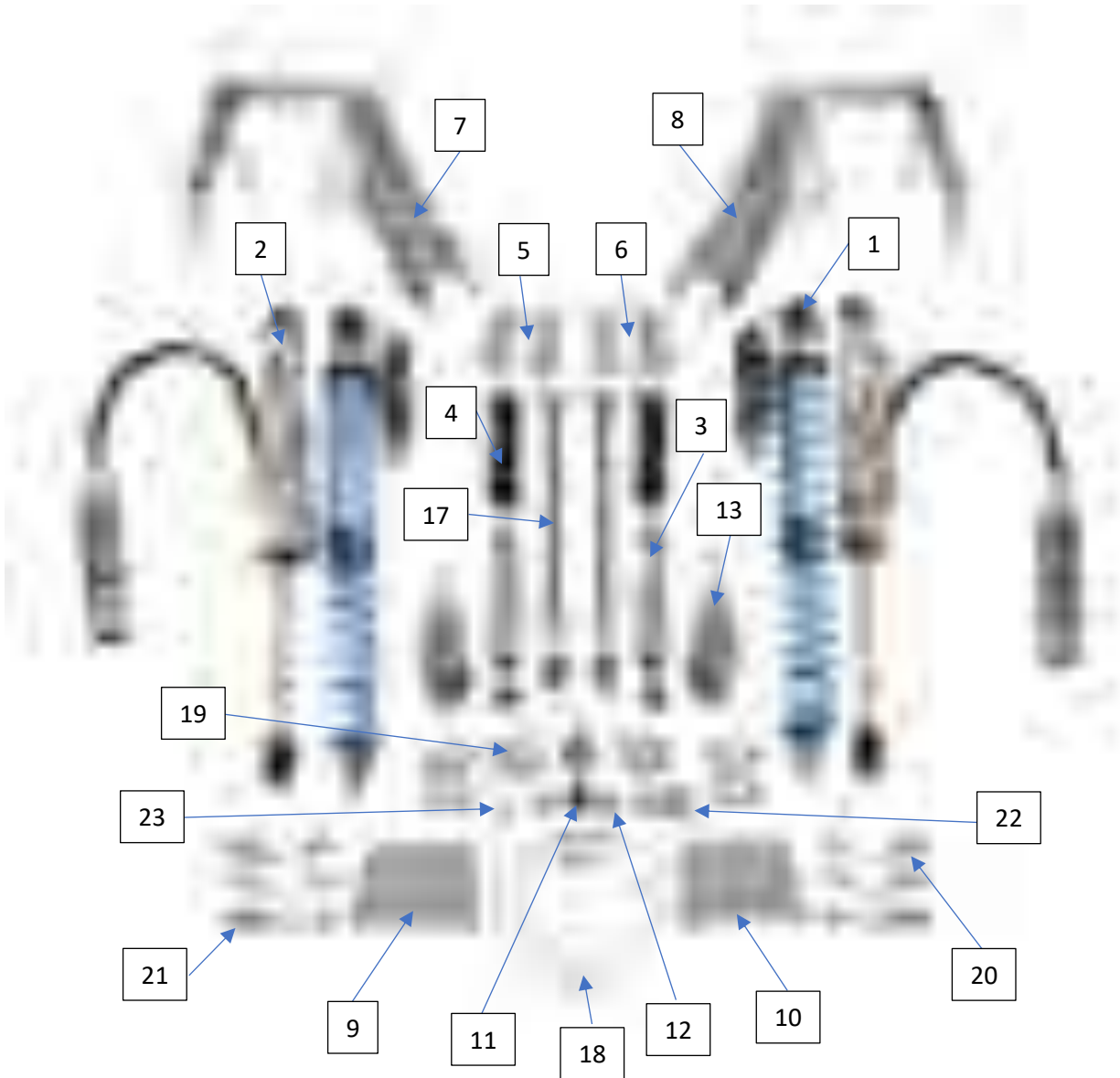

**Recommended Tools:**

- Welder
- Rivet Tool
- Drill and bit
- Welding materials
- Welding safety equipment
- Impact with standard sockets
- Sawzall/Cut off wheel, plasma torch or similar
- Masking Tape





### Safety Steps for installation

- For installing EVO MFG products always use wheel chokes to block rear tires from rolling.
  - Always make sure you have everything necessary ready before install.
  - If you have to, carefully lift front of vehicle by front frame rails extending suspension until tires leave the ground, place frame on approved jack stands for vehicle. Verify all lines/wires are not over extended.
  - Remove tires if needed for easier install.
  - Make sure to wear safety equipment (eye protection, hand protection, foot protection etc.) at all times during installation.
  - Make sure all safety precautions have been taken.
  - Always check and replace any part of vehicle that is worn or broken before starting install.
  - Do not mix anything EVO with weaker alternatives.
  - It is generally a good idea to apply liquid threadlock to all bolts.
  - Tighten included hardware to torque specifications in bottom table unless it is otherwise specified, factory bolts should be torqued to factory Jeep specifications.
- 



Caution: This kit requires welding. Welding creates a very bright arc that should not be looked at without an approved protective shield and clothing. Welded surfaces and areas in their vicinity will be very hot for a long period of time after welding. Please use caution. All welding should be performed by a professional. MIG welding is the preferred method. Remove/ Uninstall shocks prior to welding.

By purchasing this kit you are starting the next level of performance. To install this kit it requires work and finesse. This high quality system will truly enhance your vehicle to another level. Cutting, Welding, and Grinding required; not bitching and moaning. This is a toy, it should be fun!



### **INSTALL:**

After parking Jeep on a flat surface, chalk wheels and engage parking brake.

1. Disconnect battery terminals.
2. Carefully lift front of vehicle with jack by frame until tires leave the ground by a few inches minimum.
3. Carefully and securely set vehicle on weight approved jack stands. It is important that the vehicle is high enough that the tires are at least few inches from the ground as the axle will need to be lowered to remove and install parts.
4. Remove front wheels/tires.







5. Remove bolt from both driver and passenger side brake line bracket at axle. Free bracket from its detent.
- 



6. Support axle with jacks and remove front sway bar end links from vehicle. (upper stud end on sway bar link has hex key on end of the stud to prevent rotation while removing nut).
- 





7. Remove both driver and passenger side front shocks.

---





8. Lower front axle until springs can be removed. Remove front springs and upper/lower coil isolators.
- 



9. Unbolt brake line bracket from frame, do not damage line.
- 





10. Unplug the fog light connection located near the front bumper.



11. Unplug main harness connection.



12. Remove plastic track holding wires from the tabs inserted into frame on passenger side.

13. Remove wires from plastic track and tuck wires behind frame.





14. Wrap the wires in a heat shield. Start wrapping the wires about half way between the motor mount and radiator. You can cut off access heat wrap after the upper control arm mount.

15. Route wrapped wires underneath motor mounts.

16. We recommend aluminum heat wrap, specific for automotive applications. This does not come in the kit, you will need to supply this on your own.

17. Reconnect the fog light connection and computer connection.

Make sure wires are retained and out of the way where nothing will come into contact with them while cutting/welding or while suspension is cycling.



Use the 1" ID loop clamps and ¼" self tapping screws supplied in kit to retain heat wrapped wires in place.	
---	--



18. Cut coil/shock tower off of frame using plasma cutter, torch, cut off wheel and/or reciprocating saw.

There are delicate components in the vicinity of these parts that can be easily damaged, such as wiring and brake lines. Move/remove and use a fire-retardant blanket/shield to protect/cover these components during cutting.

---



19. Grind/sand frame where brackets have been cut off until a flush smooth finish is achieved. Do not cut into frame rails or gouge metal.

---





If installing airbump:

20. Line up airbump bracket using the holes in the frame. (use preexisting holes for placement reference)
21. Once placed onto correct part of frame, use a paint marker or something similar to mark the inside cutout of the airbump bracket. (pictured)
22. Once holes are lined up and marks are made, remove bracket and cut into frame following the marked lines.

Wear proper safety equipment.





23. Place the airbump bracket onto the frame using frame holes as placement reference.
  24. Loosely insert bumpstop tube into the airbump bracket. There should be approximately 5/8" of the tube hanging below the frame, use picture as reference. Tack to hold in place.
- 



Note: Airbump is not installed at this time.

---

25. Trim/remove factory inner fender liner as needed. You can purchase the EVO-3099 inner fender liner separately if preferred.
  26. At the bolt holes circled in picture, make sure the double throwdown bracket holes are concentric. Drill rearmost hole using a 9/32" bit.
  27. Mark on DTD tower where sanding is required to contour to the frame.
  28. Sand DTD tower to contour to the frame so that all gaps between the tower and frame are weldable.
- 







29. Place contoured tower back into position and install supplied bolts. If preferred fitment is achieved, tack weld (multiple locations) into place.

---

It is not recommended to fully weld at this point. Verify that nothing contacts shock tower. If so, re-adjust tower or clearance back of tower.



30. Weld all points of contact to the frame and frame bracket. Make sure to weld on the underside of frame and anywhere on the back side that you can reach.

---

Factory steering box bolts will need to be reinstalled on the driver side airbump bracket's forward most holes. **DO NOT weld bolts to bracket.**





31. If painting/color scheme, backing plates and backing vents, do so now.
32. Insert backing plates into pockets in tower from behind the DTD bracket.
33. Align holes in towers with backing plate.
34. Insert supplied 3/16" pop rivets. Using a rivet tool, complete rivet installation on both towers. On the forward most hole of the **mesh** backing plates, use the supplied 1/4 -20 nuts and bolts.
35. On plate behind "EVO" insert pop rivets once holes in bracket and plate are lined up. Leave the rearmost hole open (circled in above picture) for later use.

Note: Holes may need to be clearance drilled with 3/16" bit.

---





36. Install coilovers without springs and bypass shock into DTD tower using the supplied M12 hardware. Coilover should be in rear of the vehicle, bypass should be in the front.
  37. Remote reservoirs on the coilover and triple bypass should face each other.
  38. Install airbumps, make sure airbumps are empty of gas and completely compressed.
- 



39. Grinding/barrel sanding the inside of airbump tube may be necessary. Start with light grinding the inside of the tube from the bottom and work your way up about 1". Grinding above inner lip not required.
- 





40. Use supplied hardware to install the reservoir bracket and hose clamps, mounting the shock reservoir to the main coilover/bypass bracket.

---



41. Using supplied 10-24 bolt/nut and #10 washers install supplied L brackets into the main bracket using the rearmost hole located where the backing plate sits. (one without pop rivet)

42. Use the supplied 1 1/16"-3" ID hose clamp to mount the bypass shock's remote reservoir to the L bracket.

---





**For aftermarket axles:** This instruction was performed on a Spicer UD 60 axle already installed onto a Jeep, your axle may vary. This instruction is a general guide for installing the **AXLE BRACKETS** onto an aftermarket axle, your application may require modifications for installation.

1. Cut/torch all coil, sway bar and shock brackets off of axle.
2. Grind down until smooth with axle tube.



3. Clearance the trackbar bracket to clear the shock mount brackets. Use the top larger radius/bolt hole side of trackbar bracket as reference.
4. Remove any excess material on left side of cut line in picture.





5. Once trackbar material is removed, insert the supplied trackbar reinforcement plate and weld in.
  6. Allow welds to cool and insert trackbar into pocket, insert supplied M12 bolt but do not tighten bolt at this time.
- 



Axle side shock brackets come unwelded:

Using masking tape, mask off the lower portion of the shock shaft and shock mount.

Use one of the supplied bolts to loosely fasten the two shock brackets to the masked off shock/bypass and place the backing plate as pictured.

7. Tack in multiple places, remove from reservoir and weld fully.
  8. Weld all points of contact between two of the axle side shock tabs and shock tab tie in gusset. The gusset should overlap the shock tabs, with shock tabs flush with sides of gusset. (use picture for reference)
  9. Repeat process for other shock mount.
- 

Remove masking tape from reservoir.

---





10. Install 3 of the control arms (best to not have all 4 installed at this time).

11. Jack axle to approximate ride height (9" from bottom of frame to top of axle tube) and set axle to about 5-5.5 degrees of negative castor.

---





12. Place shock mount axle brackets on the axle from the bottom up and as close to axle C's as possible. Make sure to leave enough room to insert/remove shock mounting hardware.
13. Install both the coilovers (no springs installed) and bypass shocks into axle shock mount using supplied M12 hardware.
14. Manipulate/Jack axle to full bump or where shocks are fully compressed.
15. When both shocks are bottomed out and bump stop is fully compressed. Tack the axle shock brackets in place.
16. Droop axle until airbump pad can be placed directly under airbump.
17. Install and tack airbump pads in place.
18. Fully droop and uninstall shocks from axle mount and fully weld brackets on. Support axle carefully.

---

**Do not weld near exposed shock shafts.**

---







19. Tack sway bar mounting bracket on the passenger side edge of the axle trackbar bracket. Do not fully weld, may need to readjust later.

---



20. On driver side, use longer sway bar bracket. Driver/Passenger sway bar brackets should be in similar location for easy swaybar link installation when axle is level. Tack in place. Use picture as reference.

Do not fully weld at this time, may need to adjust placement later in installation.

---





43. Make sure that every bracket on the frame is tacked/welded on.
44. Install swaybar endlinks to the inside of factory swaybar (may need to make adjustments to factory swaybar).
45. Cycle axle up and down to full bump and full droop making sure no suspension component/steering component rubs and that suspension fully cycles. Turn wheels to right and left when suspension is fully up/tucked and when suspension is fully down/drooped.
46. May need to clearance the front body mount.
47. While suspension is fully extended adjust sway bar endlinks and swaybar brackets as necessary.

Verify that all brakelines, wiring and other components do not hyperextend or come into contact with anything. Longer brakelines may be required. May need to make minor adjustments.



---

**Remove all vital components at axle and fully weld all brackets once preferred fitment is achieved. Let welds cool and fully paint all bare metal. Reinstall all shocks, coilovers, swaybars, trackbar and control arms. Once vehicle is on the ground under its own weight, torque all bolts to spec using chart at bottom of instruction.**

---



48. Install springs and add 150 PSI of nitrogen back into the shocks.
49. Turn spanner nut, compressing the spring until the distance of the threaded portion between the shock end cap and the spanner is approximately 1.5" to 2". This should yield approximately 4" of lift.
50. Adjust distance as needed for desired ride height. Every vehicle is different, Passenger side will need slightly more.

Turning spanner may require a pin or spanner tool.

Tighten all spanner pinch bolts once preferred suspension adjustments are complete.

51. Double check welds.
- 





### **Set-Up and General Coilover Notes:**

Please read **before and after** installation: Included are things you should know before and after installation of coilovers and some final setup tips to maximize the performance advantages of coilovers.

Coilovers can tend to make some sliding sounds while driving. We are stepping into race car parts and some level of sound is to be expected.

Once final adjustments have been made on spring compression and the vehicle is at a lift/ride height that you are satisfied with. Rotate the top and bottom springs so that that each end of the top and bottom coil that rest on the coil slider are 180 degrees opposite each other. This will help balance the coil slider evenly and alleviate some of the associate noises. If this is unsatisfactory for your needs, there are aftermarket spring sliders that can be purchased additionally that will help alleviate this noise. Please give us a call for information on this accessory product

Spring compression applied with the coil nut on top of the springs will VARY between all vehicles and may be different at all 4 corners. This is due to added and or removed weight to the vehicle. The fact that all 4 corners have different weights from the factory, added accessories and or removing factory components all play a part in the vehicles corner weight and are always varying. Do not be afraid to adjust each coilover spring nut differently on each corner.

We recommend if 3" or more spring compression/preload is needed to achieve your desired lift height, our HD Coilover Spring set should be used, they are sold separately, contact EVO MFG for more information. Lastly the passenger side is heavier and will require slightly more spring compression.

Achievable lift height will vary between each vehicle due to the added and/or reduced weight of the vehicle. Additionally, actual lift is subjective. All Jeeps come from the factory with different heights based on accessories and spring packages etc. General lift increases are made by an average and/or an understanding of what a 3" or 4" lift etc. should be. Therefore in order to achieve the desired height you are looking for, spring changes may be needed and are sold separate to our standard kit.

We have done extensive testing on these kits with many variables and know we have an excellent spring package straight out of the box, but your vehicle and/or needs may vary and therefore a spring change may be needed to accomplish your desired setup.



Once the desired right height is achieved, lower the 2 secondary coil rings (2 silver rings inside the top coil spring) so that there is a  $\frac{1}{2}$ " gap between the bottom of the secondary rings and coil slider. The 2 secondary coil rings can be moved by a tap with a flat head screw driver against the machined groove to break the 2 loose from each other. Once loose, thread them down paying attention that there is a rubber O-ring between that will need to be pushed/rolled down as well. Set the lower ring at about  $\frac{1}{2}$ "-1" distance from the coil slider, tighten the 2 secondary rings towards each other with flathead screw driver and tap of a hammer. This  $\frac{1}{2}$ "-1" is a rough dimension and can be adjusted to your liking and additional payload carrying requirements.





- Tighten all bolts securing purchased parts to specified locations.
- After completing installation using provided instructions, go through all steps again to make sure nothing was missed, not tightened or improperly assembled.
- Some components may need to be purchased separately.
- Check turn signals, headlights, fog lights (if applicable), taillights, blinkers and windshield wipers.
- Adjust mirrors, speedometer and headlights if needed.
- Make sure all gauges are fully operational.
- Drive the vehicle slowly for a couple minutes, looking and listening for abnormal noises while driving. After modification of a vehicle there will be differences in driving experiences and capabilities, be mindful of that.
- Inspect and Retorque all Bolts after 500 miles of completed installation and regularly thereafter.
- Some modification may be required.

Recommended Torque:

Size	Grade 2		Grade 5		Grade 8		18-8 S/S	
	Coarse	Fine	Coarse	Fine	Coarse	Fine	Coarse	Fine
<b>#4*</b>	-	-	-	-	-	-	5.2	-
<b>#6*</b>	-	-	-	-	-	-	9.6	-
<b>#8*</b>	-	-	-	-	-	-	19.8	-
<b>#10*</b>	-	-	-	-	-	-	22.8	31.7
<b>1/4</b>	4	4.7	6.3	7.3	9	10	6.3	7.8
<b>5/16</b>	8	9	13	14	18	20	11	11.8
<b>3/8</b>	15	17	23	26	33	37	20	22
<b>7/16</b>	24	27	37	41	52	58	31	33
<b>1/2</b>	37	41	57	64	80	90	43	45
<b>9/16</b>	53	59	82	91	115	129	57	63
<b>5/8</b>	73	83	112	128	159	180	93	104
<b>3/4</b>	125	138	200	223	282	315	128	124
<b>7/8</b>	129	144	322	355	454	501	194	193
<b>1+</b>	188	210	483	541	682	764	287	289



EVO Manufacturing

Jeep JT Gladiator

JT Rear Coilover

EVO-3095B





Before starting installation procedure please read <http://evomfg.com>Returns-Warranties-Shipping>

**CAREFULLY READ AND FOLLOW ALL INSTRUCTIONS IN THIS MANUAL AND KEEP FOR FUTURE REFERENCE. IF YOU HAVE ANY QUESTIONS ABOUT THE PRODUCT CALL EVO MANUFACTURING. FAILURE TO FOLLOW GUIDELINES COULD RESULT IN MALFUNCTION OF PARTS OR INJURY. PLEASE HAVE A TRAINED PROFESSIONAL ASSIST WITH OR INSTALL ALL PRODUCTS. INSTALLING EVO MFG PRODUCTS OR KITS DEMANDS SPECIFIC KNOWLEDGE, TOOLS AND EXPERIENCE. GENERAL KNOWLEDGE OF HOW TO USE LATER SPECIFIED TOOLS AND/OR LIMITED EXPERIENCE WITH EVO MFG PRODUCTS MAY NOT BE ENOUGH TO PROPERLY COMPLETE THESE TASKS. SOME OF EVO MFG PRODUCTS MAY REQUIRE TWO OR MORE PEOPLE TO INSTALL SAFELY AND CORRECTLY. DO NOT ATTEMPT ALONE, ALWAYS ENLIST THE HELP OF TRAINED PROFESSIONAL WHEN NEEDED.**

**Notes: Set Up Before installation**

**Drilling is required.**

**EVO MFG recommends this installation be performed by a trained professional.**

**Always use approved safety gear/glasses.**

**Wheel backspacing adjustments may be required.**

**Keep all mounting bolts loose (installed but not torqued) we will torque later at the end of complete installation**

**READ BEFORE INSTALL:**

Re-torque all bolts after first 100 miles

High Clearance Fenders recommended, tire size dependant

Re-torque all bolts every 3000 miles and after every off-road use

It is generally a good idea to apply liquid thread lock to all threaded bolts.

ALWAYS wear safety glasses and other approved safety gear when working on a vehicle.

All supplied bolts torqued according to chart at end of instruction.

It is recommended all installation be performed by a trained professional. Some modification may have to be done.

Paint all unfinished surfaces after install is complete.





Parts included: Table below shows JT Gladiator Rear Coilover Suspension Kit.

Description	#	Part #	Quantity
King Shocks Pair	1		1
Driver Rear Shock Mount	2	EVO-12474B	1
Pass Rear Shock Mount	3	EVO-12475B	1
Rear Trackbar Bracket	4	EVO-12423B	1
Trackbar Bracket Hardware	5	EVO-770078	1
JT Rear Brake Line	6	EVO-600170	1
JT Rear Bumpstop	7	EVO-12420	2
Carrier Bearing Spacer	8	EVO-12440	3
Rear Swaybar Link	9	EVO-12027RB	2
Swaybar Bushing	10	EVO-600077	4
Bushing Tube	11	EVO-20032	4
Crush Tube	12	EVO-20038	1
Rear Coilover Hardware	13	EVO-770093	1





#### **Recommended Tools:**

- Impact
  - Standard sockets
  - Metric Sockets
  - Drill and extra-long 25/64" bit
- 



#### Safety Steps for installation

- For installing EVO MFG products always use wheel chokes to block rear tires from rolling.
  - Always make sure you have everything necessary ready before install.
  - If you have to, carefully lift front of vehicle by front frame rails extending suspension until tires leave the ground, place frame on approved jack stands for vehicle. Verify all lines/wires are not over extended.
  - Remove tires if needed for easier install.
  - Make sure to wear safety equipment (eye protection, hand protection, foot protection etc.) at all times during installation.
  - Make sure all safety precautions have been taken.
  - Always check and replace any part of vehicle that is worn or broken before starting install.
  - Do not mix anything EVO with weaker alternatives.
  - It is generally a good idea to apply liquid threadlock to all bolts.
  - Tighten included hardware to torque specifications in bottom table unless it is otherwise specified, factory bolts should be torqued to factory Jeep specifications.
- 





## INSTALL

After parking Jeep on a flat surface, chalk wheels and engage parking brake.

1. While safely parked on ground. Loosen all rear control arm and trackbar bolts at both axle and frame. **DO NOT REMOVE.** Just loosen a few turns to remove bolt compression on control arm bushings.
- 





2. Carefully lift rear of vehicle with jack by frame until tires leave the ground by a few inches minimum.
  3. Carefully and securely set vehicle on weight approved jack stands. It is important that the vehicle is high enough that the tires are at least few inches from the ground as the axle will need to be lowered to remove and install parts.
  4. Remove rear wheels.
- 



5. Rubicon Models: At differential, carefully pull outward on red clip at axle disconnect until it stops. It should move out about a 1/8". Then depress clip and disconnect clip/connection.
  6. Remove breather hose from differential connection. **Vehicle wiring and hoses vary, make sure all wires, hoses, lines etc. from frame to axle are freed up giving ample length to move axle downward as needed before proceeding, verify wiring/hoses etc. do not get stretched while lowering axle during this installation.**
- 





7. While vehicle is on jacks, remove the carrier bearing bolts. Add the supplied 3 carrier bearing spacers in between carrier bearing bracket and mounting holes on crossmember. Use supplied M10 bolts to mount the carrier bearing.

**Apply liquid thread lock to all bolts**



8. Remove both driver and passenger side swaybar link bolts at axle and swaybar, remove swaybar links and rotate sway down and out of the way.

**There is a 6mm allen key inside both driver and passenger side rear lower sway bar bolts. Tighten the allen head to allow nut to unscrew.**





Vehicle wiring and hoses vary, make sure all wires, hoses, lines etc from chassis to axle are freed up giving ample length to move axle downward as needed before proceeding, verify wiring/hoses etc do not get stretched while lowering axle in next steps.

9. Lightly jack front driver side axle tube slightly. Support driver side axle with jack stand
10. With axle slightly supported remove both shock bolts from axle.
11. Repeat this step on passenger side.

**Varying axle jack tension to the right amount will alleviate load on the bolt and allow it to freely slide out.**

---



12. Remove rear trackbar bolt at axle. Retain hardware	
--	--

13. Move trackbar up and out of the way.	
--	--

---

14. Remove the two bolts holding caliper to axle, then remove the smaller speed sensor bolt and pull the sensor out of brake assembly.

15. Pull off calipers and sensor and support caliper assembly by frame. **Do not hang calipers by brake line.**

**Do not remove brake line at this time.**





16. Detach brakeline and wire retaining clips from the inside of frame where rear shock and bracket will be installed.

---

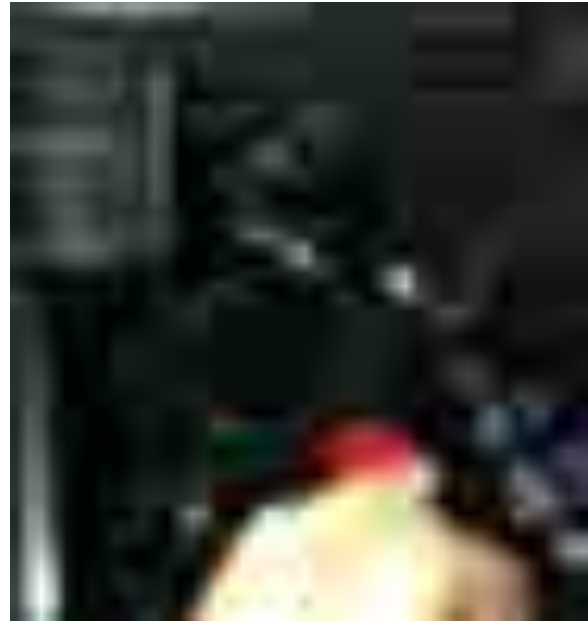

17. Lower jack under axle giving room to remove rear springs. Be sure that springs can be easily removed, forcing the springs out when under any load is not recommended.

Repeat on passenger side

---





18. Using a 25/64" drill bit, at a slight downward angle, drill through both sides of frame. **Make sure drill is angled in such a way that it wont drill into the subframe or brake lines on inner side of frame.**

---



19. Using a 16mm retracting wrench remove factory bolt, retain for later use.

---







20. Insert rear coilover support tower over factory rear shock mount at frame. And forward body mount stud.

Light trimming of pinch seam will be required. Reference picture.

---



21. Loosely reinstall the body mount bolt, using a 16mm socket, through the EVO MFG reinforcement bracket and into the body mount bracket.

---





22. Jack axle up until shock bolts line up with axle mounting holes. **Be very aware that vehicle does not lift off chassis/frame jack stands while jacking.**

23. Insert factory bolt and loosely attach nut. Follow factory torque specs for shock bolts.

---



24. Tighten supplied 3/8" (rearmost) bolt and nut. Use table at bottom of instruction for proper torque specs.

---





25. Assemble supplied rear swaybar links.  
Using light oil such as WD 40, lubricate inner surface of link loops. Tap or vice in supplied rubber bushings. Lubricate inner surface of rubber bushings. Tap or vice in supplied swaybar tube sleeves.

---



26. Install sway bars using factory hardware.  
Make sure axle side sway bar links are attached on inside of factory sway bar.

---





27. Install rear bump stop extensions to axle pads on both passenger and driver side axle pads using supplied 5/16" x .75 bolts, washers and nuts.
- 



28. Remove rear trackbar bolt at axle. Move trackbar down under/out of factory bracket. Swing trackbar above axle bracket.
  29. Take EVO bracket with U bolt side on the right, place it on the axle tube, slide the EVO bracket onto factory bracket from right to left. **EVO bracket slides INTO factory trackbar bracket not over the top.**
  30. At lower original bolt mounting location, insert supplied crush sleeve into bracket and loosely install supplied bolt at this location. Loosely install supplied U Bolt at axle tube.
  31. On driver side of bracket with bracket loosely installed, drill 3/8" hole through factory bracket. Install supplied hardware.
  32. Torque all bracket bolts.
  33. Insert trackbar into new higher trackbar location from the top down. Loosely install factory trackbar bolt. Do not torque trackbar bolt at this time. This should be done on the ground at ride height later in this installation.
- 

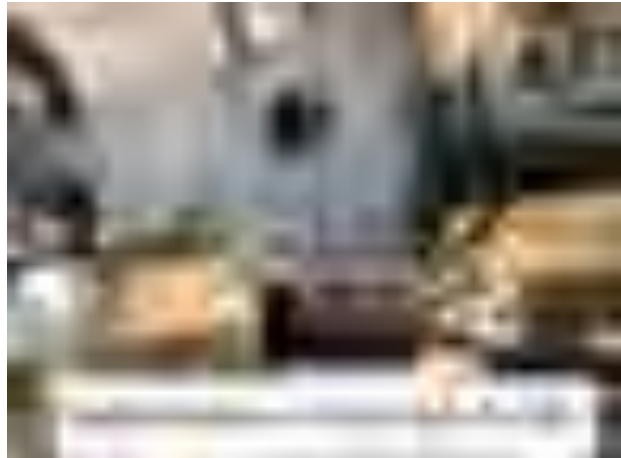



34. Reinstall the caliper and speed sensor on both sides of axle. Tighten bolts to Jeep specifications.

Remove banjo bolt from caliper (will be installing EVO MFG brake line)

**Note:** Carefully move brake line. Do not crimp/pinch line. Always check for leaking fluids and that brakes work correctly.

---



35. Moving swiftly/carefully separate the hard line from the bracket/hose on frame by holding hardline with a 12mm wrench and unscrewing the rubber hose with a 16mm wrench.

---





36. Install new copper crush washers on to the factory banjo bolt, Insert the factory banjo bolt with copper crush washer on through the banjo of the new stainless-steel brake line, then slip another copper crush washer on.



37. Using a 15mm socket, secure your new stainless steel break line to the break caliper using factory hardware, tighten the banjo bolt to 276 in. lbs. of torque (**at caliper, hard line elbow extends towards front of vehicle and angled up as much as possible.**)



**Note: Carefully move line. Do not crimp/pinch line. Always check for leaking fluids and that brakes work correctly. Bleeding brakes is extremely important to be done properly. Follow factory specifications in doing so. Consultation/should be performed by a trained professional mechanic.**



38. Using zip tie loosely secure rubber gromet on abs line to new brake line once installed.

Do NOT tighten more than a few clicks after being loosely secured.

---



---

39. Once set on ground, roll vehicle about 10 feet at a slow pace to let all suspension components to settle.	
---	--

40. Put in park and turn vehicle off, chalk tires.	
--	--

Reconnect all disconnected wiring and breather hoses. Verify adequate length of all wiring/hoses at full drop of suspension and adjuster as needed.



41. Once vehicle is on ground under its own weight. Access lift requirement/adjustment needed (“I would like it 1” higher/lower”). If changes in lift need to be made. Carefully lift vehicle up by front frame until tires leave the ground, extending suspension fully and carefully set on jack stands. Using Allen wrench, loosen set screw on coil nut, do not remove set screw.
- 



42. Using a spanner tool or other, turn coil up to lower the body or turn down to raise the body. At this point additional lift will be roughly 1 to 1 on your previous assessment of lift. Moving coil nut 1” will roughly raise or lower the body the same distance. Most setups will have the coil nut threaded down between roughly 1-2 inches.
43. Tighten coil nut set screw located on coil nut.
44. Carefully lift vehicle, remove jack stands lower vehicle down to the ground.
- 



Tighten all control arm/trackbar/all other bolts to spec.

---





### **Set-Up and General Coilover Notes:**

Please read **before and after** installation: Included are things you should know before and after installation of coilovers and some final setup tips to maximize the performance advantages of coilovers.

Coilovers can tend to make some sliding sounds while driving. We are stepping into race car parts and some level of sound is to be expected.

Once final adjustments have been made on spring compression and the vehicle is at a lift/ride height that you are satisfied with. Rotate the top and bottom springs so that that each end of the top and bottom coil that rest on the coil slider are 180 degrees opposite each other. This will help balance the coil slider evenly and alleviate some of the associate noises. If this is unsatisfactory for your needs, there are aftermarket spring sliders that can be purchased additionally that will help alleviate this noise. Please give us a call for information on this accessory product.

Spring compression applied with the coil nut on top of the springs will VARY between all vehicles and may be different at all 4 corners. This is due to added and or removed weight to the vehicle. The fact that all 4 corners have different weights from the factory, added accessories and or removing factory components all play a part in the vehicles corner weight and are always varying. Do not be afraid to adjust each coilover spring nut differently on each corner.

We recommend if 3" or more spring compression/preload is needed to achieve your desired lift height, our HD Coilover Spring set should be used, they are sold separately, contact EVO MFG for more information. Lastly the passenger side is heavier and will require slightly more spring compression.

Achievable lift height will vary between each vehicle due to the added and/or reduced weight of the vehicle. Additionally, actual lift is subjective. All Jeeps come from the factory with different heights based on accessories and spring packages etc. General lift increases are made by an average and/or an understanding of what a 3" or 4" lift etc. should be. Therefore in order to achieve the desired height you are looking for, spring changes may be needed and are sold separate to our standard kit.

We have done extensive testing on these kits with many variables and know we have an excellent spring package straight out of the box, but your vehicle and/or needs may vary and therefore a spring change may be needed to accomplish your desired setup.



Once the desired right height is achieved, lower the 2 secondary coil rings (2 silver rings inside the top coil spring) so that there is a  $\frac{1}{2}$ " gap between the bottom of the secondary rings and coil slider. The 2 secondary coil rings can be moved by a tap with a flat head screw driver against the machined groove to break the 2 loose from each other. Once loose, thread them down paying attention that there is a rubber O-ring between that will need to be pushed/rolled down as well. Set the lower ring at about  $\frac{1}{2}$ "-1" distance from the coil slider, tighten the 2 secondary rings towards each other with flathead screw driver and tap of a hammer. This  $\frac{1}{2}$ "-1" is a rough dimension and can be adjusted to your liking and additional payload carrying requirements.





After Install:

- Tighten all bolts securing purchased parts to specified locations.
- After completing installation using provided instructions, go through all steps again to make sure nothing was missed, not tightened or improperly assembled.
- Some components may need to be purchased separately.
- Check turn signals, headlights, fog lights (if applicable), taillights, blinkers and windshield wipers.
- Adjust mirrors, speedometer and headlights if needed.
- Make sure all gauges are fully operational.
- Drive the vehicle slowly for a couple minutes, looking and listening for abnormal noises while driving. After modification of a vehicle there will be differences in driving experiences and capabilities, be mindful of that.
- Inspect and Retorque all Bolts after 500 miles of completed installation and regularly thereafter.
- Some modification may be required.

Recommended Torque:

Size	Grade 2		Grade 5		Grade 8		18-8 S/S	
	Coarse	Fine	Coarse	Fine	Coarse	Fine	Coarse	Fine
<b>#4*</b>	-	-	-	-	-	-	5.2	-
<b>#6*</b>	-	-	-	-	-	-	9.6	-
<b>#8*</b>	-	-	-	-	-	-	19.8	-
<b>#10*</b>	-	-	-	-	-	-	22.8	31.7
<b>1/4</b>	4	4.7	6.3	7.3	9	10	6.3	7.8
<b>5/16</b>	8	9	13	14	18	20	11	11.8
<b>3/8</b>	15	17	23	26	33	37	20	22
<b>7/16</b>	24	27	37	41	52	58	31	33
<b>1/2</b>	37	41	57	64	80	90	43	45
<b>9/16</b>	53	59	82	91	115	129	57	63
<b>5/8</b>	73	83	112	128	159	180	93	104
<b>3/4</b>	125	138	200	223	282	315	128	124
<b>7/8</b>	129	144	322	355	454	501	194	193
<b>1+</b>	188	210	483	541	682	764	287	289



EVO Manufacturing

Jeep Wrangler JL/JT Gladiator

Front Vented/Non Vented Inner Fender Liner

EVO-3097/V, EVO-3098/V, EVO-3099/V





Before starting installation procedure please read <http://evomfg.com>Returns-Warranties-Shipping>

---

**CAREFULLY READ AND FOLLOW ALL INSTRUCTIONS IN THIS MANUAL AND KEEP FOR FUTURE REFERENCE. IF YOU HAVE ANY QUESTIONS ABOUT THE PRODUCT CALL EVO MANUFACTURING. FAILURE TO FOLLOW GUIDELINES COULD RESULT IN MALFUNCTION OF PARTS OR INJURY. PLEASE HAVE A TRAINED PROFESSIONAL ASSIST WITH OR INSTALL ALL PRODUCTS. INSTALLING EVO MFG PRODUCTS OR KITS DEMANDS SPECIFIC KNOWLEDGE, TOOLS AND EXPERIENCE. GENERAL KNOWLEDGE OF HOW TO USE LATER SPECIFIED TOOLS AND/OR LIMITED EXPERIENCE WITH EVO MFG PRODUCTS MAY NOT BE ENOUGH TO PROPERLY COMPLETE THESE TASKS. SOME OF EVO MFG PRODUCTS MAY REQUIRE TWO OR MORE PEOPLE TO INSTALL SAFELY AND CORRECTLY. DO NOT ATTEMPT ALONE, ALWAYS ENLIST THE HELP OF TRAINED PROFESSIONAL WHEN NEEDED.**

**Notes: Set Up Before installation**

**These instructions involve how to install Inner Liners with factory fenders.**

**This installation process will vary with aftermarket fenders.**

**If installing with aftermarket fenders work around these steps to install.**

**Inner fenders must mount to all body connections directly and then install all other fender parts or supports to the inner fender section. Sandwiching inner fenders between.**

**Do not mount inner fenders to outside of other parts.**

**Some adjustments may be needed to secure liner properly per individual vehicle setup.**

**Keep all mounting bolts loose (installed but not torqued) we will torque later at the end of complete installation**

**READ BEFORE INSTALL:**

It is generally a good idea to apply Loctite to all threaded bolts.

ALWAYS wear safety glasses and other approved safety gear when working on a vehicle.

All supplied bolts torqued according to chart at end of instruction.

It is recommended all installation be performed by a trained professional. Some modification may have to be done.

Paint all unfinished surfaces after install is complete if preferred.



Parts included: Table below shows JL/JT Front Inner Fender Liners.

Product Prt. #	Description	#	Part #	Quantity
EVO-3097/V	Driver Front Panel	1	EVO-12444/ EVO-12472	1
	Driver Middle Panel	2	EVO-12445	1
	Driver Middle Rear Panel	3	EVO-12446	1
	Driver Rear Panel	4	EVO-12447	1
	Passenger Front Panel (Vented/Non-Vented)	5	EVO-12448/ EVO-12473	1
	Passenger Middle Panel	6	EVO-12449	1
	Passenger Middle Rear Panel	7	EVO-12450	1
	Passenger Rear Panel	8	EVO-12451	1
	Front Aluminum Backing Panel	9	EVO-12460	2
	Inner Fender Hardware	10	EVO-770090	1
EVO-3098/V	Driver Front Panel (Vented/Non-Vented)	1	EVO-12444/ EVO-12472	1
	Driver Middle Panel	2	EVO-12452	1
	Driver Middle Rear Panel	3	EVO-12453	1
	Driver Rear Panel	4	EVO-12447	1
	Passenger Front Panel (Vented/Non-Vented)	5	EVO-12448/ EVO-12473	1
	Passenger Middle Panel	6	EVO-12454	1
	Passenger Middle Rear Panel	7	EVO-12455	1
	Passenger Rear Panel	8	EVO-12451	1
	Front Aluminum Backing Panel	9	EVO-12460	2
	Inner Fender Hardware	10	EVO-770090	1
EVO-3099/V	Driver Front Panel (Vented/Non-Vented)	1	EVO-12444/ EVO-12472	1
	Driver Middle Panel	2	EVO-12456	1
	Driver Middle Rear Panel	3	EVO-12457	1
	Driver Rear Panel	4	EVO-12447	1
	Passenger Front Panel (Vented/Non-Vented)	5	EVO-12448/ EVO-12473	1
	Passenger Middle Panel	6	EVO-12458	1
	Passenger Middle Rear Panel	7	EVO-12459	1
	Passenger Rear Panel	8	EVO-12451	1
	Front Aluminum Backing Panel	9	EVO-12460	2
	Inner Fender Hardware	10	EVO-770090	1

For all NON-VENTED Inner Fender Liners, EVO-12460 will not be included.



**EVO-3097**

**EVO-3099**

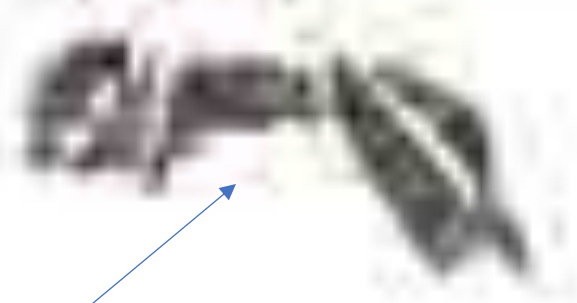
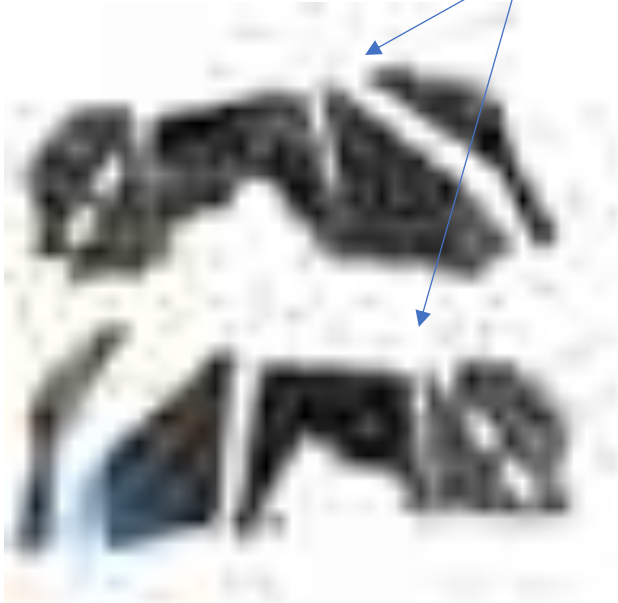

**EVO-3098**

Rear Piece

Mid-Rear Piece

Middle Piece

Mesh Backing

Front Piece





#### **Recommended Tools:**

- Allen set
  - Wrench with standard sockets
  - Drill and 3/16", 1/4" bits
  - Plastic fastener clip removal tool
  - Impact Driver
- 



#### **Safety Steps for installation**

- For installing EVO MFG products always use wheel chokes to block rear tires from rolling.
  - Always make sure you have everything necessary ready before install.
  - If you have to, carefully lift front of vehicle by front frame rails extending suspension until tires leave the ground, place frame on approved jack stands for vehicle. Verify all lines/wires are not over extended.
  - Remove tires if needed for easier install.
  - Make sure to wear safety equipment (eye protection, hand protection, foot protection etc.) at all times during installation.
  - Make sure all safety precautions have been taken.
  - Always check and replace any part of vehicle that is worn or broken before starting install.
  - Do not mix anything EVO with weaker alternatives.
  - It is generally a good idea to apply liquid threadlock to all bolts.
  - Tighten included hardware to torque specifications in bottom table unless it is otherwise specified, factory bolts should be torqued to factory Jeep specifications.
- 







## **INSTALL**

**\*Pictures are for reference only, product may vary. \***

Each inner fender liner is comprised of 4 main pieces (front, middle, mid rear and rear) and a mesh vent if you have vented Inner Fender Liners.

All pieces are etched with a part number for ease of assembly.

---





1. Using three #10 bolts and lock nuts supplied in kit, place front piece overtop of the center piece and bolt together at bolt hole locations.
  2. If you have the vented Inner Fenders, mesh insert should be placed behind both front and middle pieces. Use two more #10 bolts and lock nuts, assemble as pictured.
- 



3. Using four more of the supplied #10 bolts and lock nuts (2 for coilover and double throwdown) attach the mid-rear piece overtop of the middle piece then bolt together.
- 





4. Attach the rear piece behind the mid rear piece using 2 of the #10 bolts and corresponding nuts (at locations circled in black).

The crossed out hole leave open, you will install a bolt and nut there later.

5. Repeat previous steps on opposite side inner liner.



---

**Park vehicle on flat ground, chalk wheels, put in park and engage parking brake.  
Turn off vehicle.**

6. Using a  $\frac{1}{4}$ " drill, drill center of all 8 button clips from outside lip of factory fender.

Use pictures A and B for reference.





Once all 8 button clips have been drilled, remove all the clips completely.

Use Picture A and B for reference.



7. Using a plastic fastener clip removal tool remove the 4 button clips located just inside of the clips removed in the previous step.



8. Remove the 2 button clips on the bottom rear of the factory inner fender liner.
- 



9. Remove ALL bolts using a 10mm socket located in center section of factory fender liner.

Use picture as reference.





10. Remove button clip located at front body mount.

---



11. Remove inner liner from Jeep, then remove plastic lower body seam insert (pictured). You will not be needing them anymore.

---





12. On the passenger side, remove the top plastic clip from pinch seam and plastic wire retainer using a clip removal tool.

Use picture as reference.



13. Remove wire fasteners from all locations referenced in picture on both driver and passenger sides.

Replace wire fasteners with zip ties if preferred.





14. On driver side slip one of the supplied clip nuts onto top hole in pinch seam positioned as pictured.

---



15. On passenger side pinch seam, insert clip nut over hole in the plastic wire retainer (behind the pinch seam), where push clip used to be. (pictured)

---







16. Using the forwardmost hole in inner fender, loosely install EVO MFG inner fender liner onto Jeep mounting location using a ¼-20 bolt and nut. (Pictured)

Manipulate inner fender liner until front hole lines up with mounting hole.





17. Using the rearmost hole in inner fender, loosely install EVO MFG inner fender liner onto the Jeep using a #10 bolt and nut. (Pictured)

Manipulate inner fender liner until front/rear holes line up to body panel holes.

Some grinding of ground wire stud or liner may be needed.

---





18. Insert a ¼"-20 bolt into hole in the rear panel. Once the bolt grabs onto the previously installed clip nut, tighten down to snug.
- 



19. Manipulate EVO MFG liner to a position where fitment meets your personal preference.
20. Using an impact, drill self-tapping screws through holes in liner and into the sub frame.

**DO NOT OVER TIGHTEN**

---





21. Once everything is bolted up, check for proper fitment, you may have to manipulate part until preferred placement is achieved. Be sure not to pinch, cut or damage any wires.

---



Repeat all previous steps on opposite side.

After Install:

- Tighten all bolts securing purchased parts to specified locations.
- After completing installation using provided instructions, go through all steps again to make sure nothing was missed, not tightened or improperly assembled.
- Some components may need to be purchased separately.
- Check turn signals, headlights, fog lights (if applicable), taillights, blinkers and windshield wipers.
- Adjust mirrors, speedometer and headlights if needed.
- Make sure all gauges are fully operational.
- Drive the vehicle slowly for a couple minutes, looking and listening for abnormal noises while driving. After modification of a vehicle there will be differences in driving experiences and capabilities, be mindful of that.
- Inspect and Retorque all Bolts after 500 miles of completed installation and regularly thereafter.
- Some modification may be required.



Recommended Torque:

Size	Grade 2		Grade 5		Grade 8		18-8 S/S	
	Coarse	Fine	Coarse	Fine	Coarse	Fine	Coarse	Fine
<b>#4*</b>	-	-	-	-	-	-	5.2	-
<b>#6*</b>	-	-	-	-	-	-	9.6	-
<b>#8*</b>	-	-	-	-	-	-	19.8	-
<b>#10*</b>	-	-	-	-	-	-	22.8	31.7
<b>1/4</b>	4	4.7	6.3	7.3	9	10	6.3	7.8
<b>5/16</b>	8	9	13	14	18	20	11	11.8
<b>3/8</b>	15	17	23	26	33	37	20	22
<b>7/16</b>	24	27	37	41	52	58	31	33
<b>1/2</b>	37	41	57	64	80	90	43	45
<b>9/16</b>	53	59	82	91	115	129	57	63
<b>5/8</b>	73	83	112	128	159	180	93	104
<b>3/4</b>	125	138	200	223	282	315	128	124
<b>7/8</b>	129	144	322	355	454	501	194	193
<b>1†</b>	188	210	483	541	682	764	287	289



EVO Manufacturing  
Diesel Coilover Accessory Battery Relocate  
EVO-3106B

Before starting installation procedure please read <http://evomfg.com>Returns-Warranties-Shipping>

---

**CAREFULLY READ AND FOLLOW ALL INSTRUCTIONS IN THIS MANUAL AND KEEP FOR FUTURE REFERENCE. IF YOU HAVE ANY QUESTIONS ABOUT THE PRODUCT CALL EVO MANUFACTURING. FAILURE TO FOLLOW GUIDELINES COULD RESULT IN MALFUNCTION OF PARTS OR INJURY. PLEASE HAVE A TRAINED PROFESSIONAL ASSIST WITH OR INSTALL ALL PRODUCTS. INSTALLING EVO MFG PRODUCTS OR KITS DEMANDS SPECIFIC KNOWLEDGE, TOOLS AND EXPERIENCE. GENERAL KNOWLEDGE OF HOW TO USE LATER SPECIFIED TOOLS AND/OR LIMITED EXPERIENCE WITH EVO MFG PRODUCTS MAY NOT BE ENOUGH TO PROPERLY COMPLETE THESE TASKS. SOME OF EVO MFG PRODUCTS MAY REQUIRE TWO OR MORE PEOPLE TO INSTALL SAFELY AND CORRECTLY. DO NOT ATTEMPT ALONE, ALWAYS ENLIST THE HELP OF TRAINED PROFESSIONAL WHEN NEEDED.**

READ BEFORE INSTALL





#### **Recommended Tools:**

- Socket set
- Wrenches (English/metric)
- Rubber Mallet/Vice
- Dremel/knife/shears/cutting wheel
- Thread lock
- Grinder



---

#### Safety Steps for installation

- For installing EVO MFG products always use wheel chokes to block rear tires from rolling.
- Always make sure you have everything necessary ready before install.
- If you have to, carefully lift front of vehicle by front frame rails extending suspension until tires leave the ground, place frame on approved jack stands for vehicle. Verify all lines/wires are not over extended.
- Remove tires if needed for easier install.
- Make sure to wear safety equipment (eye protection, hand protection, foot protection etc.) at all times during installation.
- Make sure all safety precautions have been taken.
- Always check and replace any part of vehicle that is worn or broken before starting install.
- Do not mix anything EVO with weaker alternatives.
- It is generally a good idea to apply liquid threadlock to all bolts.
- Tighten included hardware to torque specifications in bottom table unless it is otherwise specified, factory bolts should be torqued to factory Jeep specifications.







**This instruction is a supplement instruction to be used in combination with EVO-3028B / BA or EVO-3092B-S60 Coilover Kits on Diesel Engine Equipped JL and Gladiators.**

**Please read and fully understand both instructions before proceeding with installation. Once installation has begun there is no reversal.**

**Some vehicles may require extension of one or both of the factory cables. Provisions for this are not included. If needed this is installer supplied.**



- 
1. From the engine compartment.  
Remove lid over accessory battery.  
Disconnect cables from battery.  
Remove battery.
  2. With Battery box empty. Using a cutting tool/cut off wheel or similar. Carefully cut out factory plastic battery box from inner fender well. Entire box should be removed. Be careful to not cut through the top. Retain the ability to reinstall the lid to engine compartment.





3. Preinstall EVO-3106B as shown with removed factory battery installed into mount. Stainless Heat Shield should be installed to the top strap with shield toward the inside of the vehicle.



4. Install assembled battery box with tray to passenger side rear portion of the coilover towers. It will bolt to tower using supplied 3 screw holes on top section of rear logo plate as shown. Contrast backing plate should be installed on the tower as well.
5. As a preassembled unit. Insert tower into vehicle wheel well and proceed with coilover install procedure.





After completing coilover install procedure. Reconnect wiring to battery. Verify correct +/- cables to correct battery terminals. If wire extension is required. Do so at this time following their manufacturer recommendations. Re-install lid over battery.

After Install:

- Double check all brake lines for leaks and or loose bolts. Make sure brakes are bled and bled properly. It is recommended to take to a professional to bleed brakes properly.
- Tighten all bolts securing urethane or rubber bushings once vehicle is under its own weight and at ride height. Track bars, control arms, etc.
- After completing installation using provided instructions, go through all steps again to make sure nothing was missed, not tightened or improperly assembled.
- Some components may need to be purchased separately.
- Check turn signals, headlights, fog lights (if applicable), taillights, blinkers and windshield wipers.
- Adjust mirrors, speedometer and headlights if needed.
- Make sure all gauges are fully operational.
- Drive the vehicle slowly for a couple minutes, looking and listening for abnormal noises while driving. After modification of a vehicle there will be differences in driving experiences and capabilities, be mindful of that.
- Inspect and Retorque all Bolts after 500 miles of completed installation and regularly thereafter.
- Some modification may be required to fit preferred size/brand tire.

**General Recommended Torque Specs:**

Size	Grade 2		Grade 5		Grade 8		18-8 S/S	
	Coarse	Fine	Coarse	Fine	Coarse	Fine	Coarse	Fine
#4*	-	-	-	-	-	-	5.2	-
#6*	-	-	-	-	-	-	9.6	-
#8*	-	-	-	-	-	-	19.8	-
#10*	-	-	-	-	-	-	22.8	31.7
1/4	4	4.7	6.3	7.3	9	10	6.3	7.8
5/16	8	9	13	14	18	20	11	11.8
3/8	15	17	23	26	33	37	20	22
7/16	24	27	37	41	52	58	31	33
1/2	37	41	57	64	80	90	43	45
9/16	53	59	82	91	115	129	57	63
5/8	73	83	112	128	159	180	93	104
3/4	125	138	200	223	282	315	128	124
7/8	129	144	322	355	454	501	194	193





EVO Manufacturing

**JL/JT FRONT ALUMILITE BUMPER INSTRUCTION**



Before starting installation procedure please read <http://evomfg.com>Returns-Warranties-Shipping>

**ALL BOLTS SHOULD BE LOOSELY INSTALLED IN EACH ASSEMBLIES BEFORE TIGHTENING/TORQUING ANY BOLTS**



**READ BEFORE INSTALL**

**Recommended Tools:**

- Socket/Tool set
- Wrenches (English/metric)
- Drill/Bits
- Thread lock
- Plastic Cutting Tool/Grinder





1. Remove Front Bumper from vehicle and remove front factory fog lights from bumper. Consult factory service manual as needed.
  
2. There are 2 different factory fog light options on the vehicle. One style light will mount direct to fog light plate (no risers) after cut and drilled as shown. Other style light will require no modification and will mount to fog light plate on 2 risers as shown on each side. Do so as needed. Both option shown on these 2 images.







3. Assemble bumper as shown. (Fog Light will vary). Winch Fairlead will need to use supplied Jog plate. This will be used on passenger side of bumper is winch is center drum (As shown) or Driver side if winch is offset drum.





4. Loosely install inner frame buckets left and right with factory hardware.





5. Loosely install winch plate as shown





6. Bring Assembled bumper to vehicle. Be aware of Fog Light wiring. It should be routed around mounting plates as bumper is brought to vehicle.





7. Install and torque all bolts. Winch can set/mounted during this procedure. Fully tighten/torque afterwards.





Skid and/or Hoop can be added during this procedure.

Skid uses winch bolts to mount.

Hoop uses upper bolt hole. Rear 2 Hoop holes need to be drilled.

After Install:

- After completing installation using provided instructions, go through all steps again to make sure nothing was missed, not tightened or improperly assembled.
- Some components may need to be purchased separately.
- Make sure all gauges are fully operational.
- Drive the vehicle slowly for a couple minutes, looking and listening for abnormal noises while driving. After modification of a vehicle there will be differences in driving experiences and capabilities, be mindful of that.
- Inspect and Retorque all Bolts after 500 miles of completed installation and regularly thereafter.



General Recommended Torque Specs:

Size	Grade 2		Grade 5		Grade 8		18-8 S/S	
	Coarse	Fine	Coarse	Fine	Coarse	Fine	Coarse	Fine
<b>#4*</b>	-	-	-	-	-	-	5.2	-
<b>#6*</b>	-	-	-	-	-	-	9.6	-
<b>#8*</b>	-	-	-	-	-	-	19.8	-
<b>#10*</b>	-	-	-	-	-	-	22.8	31.7
<b>1/4</b>	4	4.7	6.3	7.3	9	10	6.3	7.8
<b>5/16</b>	8	9	13	14	18	20	11	11.8
<b>3/8</b>	15	17	23	26	33	37	20	22
<b>7/16</b>	24	27	37	41	52	58	31	33
<b>1/2</b>	37	41	57	64	80	90	43	45
<b>9/16</b>	53	59	82	91	115	129	57	63
<b>5/8</b>	73	83	112	128	159	180	93	104
<b>3/4</b>	125	138	200	223	282	315	128	124
<b>7/8</b>	129	144	322	355	454	501	194	193



EVO Manufacturing

**JL/JT FRONT ALUMILITE BUMPER INSTRUCTION**



Before starting installation procedure please read <http://evomfg.com>Returns-Warranties-Shipping>

**ALL BOLTS SHOULD BE LOOSELY INSTALLED IN EACH ASSEMBLIES BEFORE TIGHTENING/TORQUING ANY BOLTS**





**READ BEFORE INSTALL**

**Recommended Tools:**

- Socket/Tool set
- Wrenches (English/metric)
- Drill/Bits
- Thread lock
- Plastic Cutting Tool/Grinder





1. Remove Front Bumper from vehicle and remove front factory fog lights from bumper. Consult factory service manual as needed.
  
2. There are 2 different factory fog light options on the vehicle. One style light will mount direct to fog light plate (no risers) after cut and drilled as shown. Other style light will require no modification and will mount to fog light plate on 2 risers as shown on each side. Do so as needed. Both option shown on these 2 images.





3. Assemble bumper as shown. (Fog Light will vary). Winch Fairlead will need to use supplied Jog plate. This will be used on passenger side of bumper is winch is center drum (As shown) or Driver side if winch is offset drum.





4. Loosely install inner frame buckets left and right with factory hardware.





5. Loosely install winch plate as shown





6. Bring Assembled bumper to vehicle. Be aware of Fog Light wiring. It should be routed around mounting plates as bumper is brought to vehicle.





7. Install and torque all bolts. Winch can set/mounted during this procedure. Fully tighten/torque afterwards.





Skid and/or Hoop can be added during this procedure.

Skid uses winch bolts to mount.

Hoop uses upper bolt hole. Rear 2 Hoop holes need to be drilled.

After Install:

- After completing installation using provided instructions, go through all steps again to make sure nothing was missed, not tightened or improperly assembled.
- Some components may need to be purchased separately.
- Make sure all gauges are fully operational.
- Drive the vehicle slowly for a couple minutes, looking and listening for abnormal noises while driving. After modification of a vehicle there will be differences in driving experiences and capabilities, be mindful of that.
- Inspect and Retorque all Bolts after 500 miles of completed installation and regularly thereafter.





**General Recommended Torque Specs:**

Size	Grade 2		Grade 5		Grade 8		18-8 S/S	
	Coarse	Fine	Coarse	Fine	Coarse	Fine	Coarse	Fine
<b>#4*</b>	-	-	-	-	-	-	5.2	-
<b>#6*</b>	-	-	-	-	-	-	9.6	-
<b>#8*</b>	-	-	-	-	-	-	19.8	-
<b>#10*</b>	-	-	-	-	-	-	22.8	31.7
<b>1/4</b>	4	4.7	6.3	7.3	9	10	6.3	7.8
<b>5/16</b>	8	9	13	14	18	20	11	11.8
<b>3/8</b>	15	17	23	26	33	37	20	22
<b>7/16</b>	24	27	37	41	52	58	31	33
<b>1/2</b>	37	41	57	64	80	90	43	45
<b>9/16</b>	53	59	82	91	115	129	57	63
<b>5/8</b>	73	83	112	128	159	180	93	104
<b>3/4</b>	125	138	200	223	282	315	128	124
<b>7/8</b>	129	144	322	355	454	501	194	193



EVO Manufacturing  
Jeep Wrangler JL/JLU  
Rear Alumilite Bumper  
EVO- 3111AL





Before starting installation procedure please read <http://evomfg.com>Returns-Warranties-Shipping>

**CAREFULLY READ AND FOLLOW ALL INSTRUCTIONS IN THIS MANUAL AND KEEP FOR FUTURE REFERENCE. IF YOU HAVE ANY QUESTIONS ABOUT THE PRODUCT CALL EVO MANUFACTURING. FAILURE TO FOLLOW GUIDELINES COULD RESULT IN MALFUNCTION OF PARTS OR INJURY. PLEASE HAVE A TRAINED PROFESSIONAL ASSIST WITH OR INSTALL ALL PRODUCTS. INSTALLING EVO MFG PRODUCTS OR KITS DEMANDS SPECIFIC KNOWLEDGE, TOOLS AND EXPERIENCE. GENERAL KNOWLEDGE OF HOW TO USE LATER SPECIFIED TOOLS AND/OR LIMITED EXPERIENCE WITH EVO MFG PRODUCTS MAY NOT BE ENOUGH TO PROPERLY COMPLETE THESE TASKS. SOME OF EVO MFG PRODUCTS MAY REQUIRE TWO OR MORE PEOPLE TO INSTALL SAFELY AND CORRECTLY. DO NOT ATTEMPT ALONE, ALWAYS ENLIST THE HELP OF TRAINED PROFESSIONAL WHEN NEEDED.**

**Notes: Set Up Before installation**

**Cutting and grinding will be necessary for this installation.**

**May need to use a second person to ease install.**

**Keep all mounting bolts loose (installed but not torqued) we will torque later at the end of complete installation**

**READ BEFORE INSTALL:**

It is generally a good idea to apply Loctite to all threaded bolts.

ALWAYS wear safety glasses and other approved safety gear when working on a vehicle.

All supplied bolts torqued according to chart at end of instruction.

It is recommended all installation be performed by a trained professional. Some modification may have to be done.

Paint all unfinished surfaces after install is complete.

On aluminum bumpers, heat should not be applied due to aluminum properties



Parts included: Table below shows EVO Alumilite JL JLU Bumper.

Description	Part # AL	Quantity
JL JLU Alumilite Bumper	EVO-12498AL	1
JL JLU Alumilite Bumper Insert	EVO-12499AL	1
JL JLU Rear D Ring Shackle Plates	EVO-12500	2
Alumilite Bumper Mount, Left	EVO-12501	1
Alumilite Bumper Mount, Left	EVO-12502	1
JL JLU Rear Bumper Frame Insert Nut Plate, Right	EVO-12504	1
Backup Senser Mounts	EVO-12503	4
JL JLU Alumilite Bumper Hardware	EVO-770098	1





#### **Recommended Tools:**

- Allen set/ Driver Sockets
  - Metric/Standard sockets and wrenches
  - Grinder
  - Mallet/Hammer
- 



#### **Safety Steps for installation**

- For installing EVO MFG products always use wheel chokes to block rear tires from rolling.
  - Always make sure you have everything necessary ready before install.
  - If you have to, carefully lift front of vehicle by front frame rails extending suspension until tires leave the ground, place frame on approved jack stands for vehicle. Verify all lines/wires are not over extended.
  - Remove tires if needed for easier install.
  - Make sure to wear safety equipment (eye protection, hand protection, foot protection etc.) at all times during installation.
  - Make sure all safety precautions have been taken.
  - Always check and replace any part of vehicle that is worn or broken before starting install.
  - Do not mix anything EVO with weaker alternatives.
  - It is generally a good idea to apply liquid threadlock to all bolts.
  - Tighten included hardware to torque specifications in bottom table unless it is otherwise specified, factory bolts should be torqued to factory Jeep specifications.
- 





## **Safely park car on flat ground, put in park and chock wheels.**

Various factory bumper options are available. Factory bumper removal steps therefore will vary. This is just a guide, follow factory manual if further instruction is required.

PAY ATTENTION TO BACKUP SENSOR ORIENTATION. THEY WILL NEED TO BE INSTALLED IN THE SAME WAY LATER.

### **INSTALL:**

1. Install center insert onto main bumper using 6 supplied button head bolts and nuts.





## 2. IF INSTALLING BACKUP SENSORS:

Using small button head screws. Install backup sensors in the same origination as they were removed from vehicle.

If not installing sensor. Install plastic plugs into 4 sensor holes.



Careful when installing sensor hardware. Use a well fitted wrench and lightly tighten.



3. Install D Ring Shackle mounts and Bumper install plate as shown using supplied 3/8" bolt on upper hole and factory bolts for frame holes.

Both sides of vehicle.

---

Torque these bolts to factory specification for factory bolts and tab for supplied bolts.



4. Using the bumper install plate lower 45-degree edge as a guide. Grind lower/bottom edge of frame to match mounting plate.
- 







5. Insert nut tab plate into right side frame. Nut over hole in bottom of frame and tab extension through hole inside of frame



Remove Trailer Hitch Tab Plate

If Equipped

---





6. Slide Preassembled bumper over previously installed D Ring Shackle Tabs previously installed on the frame. This may take some manipulation and tabs with mallet.
- 

Frames do vary. Therefore, some manipulation of frame/tab angle may be needed to insert into bumper. Use of a mallet/hammer to adjust angle/width of tabs to insert into bumper may be needed. Do so as needed.

---



Be cautious of sensor wiring. Do not pinch wires when installing bumper.





---

Install Supplied Button heads into top 2 bumper mounting holes.

Reinstall factory bolt under lower driver side frame

Install supplied M12 bolt on passenger side into previously installed nut tab. Hold nut tab through side of frame.



After Install:

- Tighten all bolts securing purchased parts to specified locations.
- After completing installation using provided instructions, go through all steps again to make sure nothing was missed, not tightened or improperly assembled.
- Some components may need to be purchased separately.
- Check turn signals, headlights, fog lights (if applicable), taillights, blinkers and windshield wipers.
- Adjust mirrors, speedometer and headlights if needed.
- Make sure all gauges are fully operational.
- Drive the vehicle slowly for a couple minutes, looking and listening for abnormal noises while driving. After modification of a vehicle there will be differences in driving experiences and capabilities, be mindful of that.
- Inspect and Retorque all Bolts after 500 miles of completed installation and regularly thereafter.
- Some modification may be required.

Recommended Torque:

Size	Grade 2		Grade 5		Grade 8		18-8 S/S	
	Coarse	Fine	Coarse	Fine	Coarse	Fine	Coarse	Fine
<b>#4*</b>	-	-	-	-	-	-	5.2	-
<b>#6*</b>	-	-	-	-	-	-	9.6	-
<b>#8*</b>	-	-	-	-	-	-	19.8	-
<b>#10*</b>	-	-	-	-	-	-	22.8	31.7
<b>1/4</b>	4	4.7	6.3	7.3	9	10	6.3	7.8
<b>5/16</b>	8	9	13	14	18	20	11	11.8
<b>3/8</b>	15	17	23	26	33	37	20	22
<b>7/16</b>	24	27	37	41	52	58	31	33
<b>1/2</b>	37	41	57	64	80	90	43	45
<b>9/16</b>	53	59	82	91	115	129	57	63
<b>5/8</b>	73	83	112	128	159	180	93	104
<b>3/4</b>	125	138	200	223	282	315	128	124
<b>7/8</b>	129	144	322	355	454	501	194	193
<b>1+</b>	188	210	483	541	682	764	287	289



EVO Manufacturing  
Jeep Wrangler JL/JLU  
Rear Alumilite Bumper  
EVO- 3111AL





Before starting installation procedure please read <http://evomfg.com>Returns-Warranties-Shipping>

**CAREFULLY READ AND FOLLOW ALL INSTRUCTIONS IN THIS MANUAL AND KEEP FOR FUTURE REFERENCE. IF YOU HAVE ANY QUESTIONS ABOUT THE PRODUCT CALL EVO MANUFACTURING. FAILURE TO FOLLOW GUIDELINES COULD RESULT IN MALFUNCTION OF PARTS OR INJURY. PLEASE HAVE A TRAINED PROFESSIONAL ASSIST WITH OR INSTALL ALL PRODUCTS. INSTALLING EVO MFG PRODUCTS OR KITS DEMANDS SPECIFIC KNOWLEDGE, TOOLS AND EXPERIENCE. GENERAL KNOWLEDGE OF HOW TO USE LATER SPECIFIED TOOLS AND/OR LIMITED EXPERIENCE WITH EVO MFG PRODUCTS MAY NOT BE ENOUGH TO PROPERLY COMPLETE THESE TASKS. SOME OF EVO MFG PRODUCTS MAY REQUIRE TWO OR MORE PEOPLE TO INSTALL SAFELY AND CORRECTLY. DO NOT ATTEMPT ALONE, ALWAYS ENLIST THE HELP OF TRAINED PROFESSIONAL WHEN NEEDED.**

**Notes: Set Up Before installation**

**Cutting and grinding will be necessary for this installation.**

**May need to use a second person to ease install.**

**Keep all mounting bolts loose (installed but not torqued) we will torque later at the end of complete installation**

**READ BEFORE INSTALL:**

It is generally a good idea to apply Loctite to all threaded bolts.

ALWAYS wear safety glasses and other approved safety gear when working on a vehicle.

All supplied bolts torqued according to chart at end of instruction.

It is recommended all installation be performed by a trained professional. Some modification may have to be done.

Paint all unfinished surfaces after install is complete.

On aluminum bumpers, heat should not be applied due to aluminum properties



Parts included: Table below shows EVO Alumilite JL JLU Bumper.

Description	Part # AL	Quantity
JT Rear Alumilite Bumper	EVO-12515AL	1
JT Center Bumper Plate	EVO-12516AL	1
JT Rear Licence Plate Light Bracket1	EVO-12517	2
JT Rear Licence Plate Light Bracket2	EVO-12518	1
JT Rear Logo Light Bracket	EVO-12519	1
Jeep Gladiator Rear Bumper Trailer Plug Bracket	EVO-12520	1
Jeep Gladiator Rear Bumper Foot Plate, Aluminum	EVO-12521AL	1
Backup Sensor Mounting bracket, JL Rear Bumper	EVO-12503	4
Jeep Gladiator Rear Bumper Hardware	EVO-770100	1





#### **Recommended Tools:**

- Allen set/ Driver Sockets
  - Metric/Standard sockets and wrenches
  - Grinder
  - Mallet/Hammer
- 



#### Safety Steps for installation

- For installing EVO MFG products always use wheel chokes to block rear tires from rolling.
  - Always make sure you have everything necessary ready before install.
  - If you have to, carefully lift front of vehicle by front frame rails extending suspension until tires leave the ground, place frame on approved jack stands for vehicle. Verify all lines/wires are not over extended.
  - Remove tires if needed for easier install.
  - Make sure to wear safety equipment (eye protection, hand protection, foot protection etc.) at all times during installation.
  - Make sure all safety precautions have been taken.
  - Always check and replace any part of vehicle that is worn or broken before starting install.
  - Do not mix anything EVO with weaker alternatives.
  - It is generally a good idea to apply liquid threadlock to all bolts.
  - Tighten included hardware to torque specifications in bottom table unless it is otherwise specified, factory bolts should be torqued to factory Jeep specifications.
- 







## **Safely park car on flat ground, put in park and chock wheels.**

Various factory bumper options are available. Factory bumper removal steps therefore will vary. This is just a guide, follow factory manual if further instruction is required.

PAY ATTENTION TO BACKUP SENSOR ORIENTATION. THEY WILL NEED TO BE INSTALLED IN THE SAME WAY LATER.

### **INSTALL:**

1. Install center insert and foot set onto main bumper using supplied button head bolts and nuts.





## 2. IF INSTALLING BACKUP SENSORS:

---

Using small button head screws. Install backup sensors in the same origination as they were removed from vehicle.

If not installing sensor. Install plastic plugs into 4 sensor holes.

---



Careful when installing sensor hardware. Use a well fitted wrench and lightly tighten.

---

Torque these bolts to factory specification for factory bolts and tab for supplied bolts.

---



3. Install Factory Trailer Plug and License Light (Factory Light Reused) as shown. Second Factory License Plate Light can be install on rear side of EVO Logo with supplied bracket as shown using License plate bolts.





#### 4. Trim Factory Trailer Hitch As Shown

---



5. Install Bumper to vehicle using 4 supplied Socket Head Cap Screws.



---

Be cautious of sensor wiring. Do not pinch wires when installing bumper.

Connect Wiring to sensors and hitch plug, lights



After Install:

- Tighten all bolts securing purchased parts to specified locations.
- After completing installation using provided instructions, go through all steps again to make sure nothing was missed, not tightened or improperly assembled.
- Some components may need to be purchased separately.
- Check turn signals, headlights, fog lights (if applicable), taillights, blinkers and windshield wipers.
- Adjust mirrors, speedometer and headlights if needed.
- Make sure all gauges are fully operational.
- Drive the vehicle slowly for a couple minutes, looking and listening for abnormal noises while driving. After modification of a vehicle there will be differences in driving experiences and capabilities, be mindful of that.
- Inspect and Retorque all Bolts after 500 miles of completed installation and regularly thereafter.
- Some modification may be required.

Recommended Torque:

Size	Grade 2		Grade 5		Grade 8		18-8 S/S	
	Coarse	Fine	Coarse	Fine	Coarse	Fine	Coarse	Fine
<b>#4*</b>	-	-	-	-	-	-	5.2	-
<b>#6*</b>	-	-	-	-	-	-	9.6	-
<b>#8*</b>	-	-	-	-	-	-	19.8	-
<b>#10*</b>	-	-	-	-	-	-	22.8	31.7
<b>1/4</b>	4	4.7	6.3	7.3	9	10	6.3	7.8
<b>5/16</b>	8	9	13	14	18	20	11	11.8
<b>3/8</b>	15	17	23	26	33	37	20	22
<b>7/16</b>	24	27	37	41	52	58	31	33
<b>1/2</b>	37	41	57	64	80	90	43	45
<b>9/16</b>	53	59	82	91	115	129	57	63
<b>5/8</b>	73	83	112	128	159	180	93	104
<b>3/4</b>	125	138	200	223	282	315	128	124
<b>7/8</b>	129	144	322	355	454	501	194	193
<b>1+</b>	188	210	483	541	682	764	287	289



EVO Manufacturing

**JEEP WRANGLER JL/JLU FASCIA WITH D RING SHACKLE REAR BUMPER  
DELETE, ALUMINUM**





Before starting installation procedure please read <http://evomfg.com>Returns-Warranties-Shipping>

---

**CAREFULLY READ AND FOLLOW ALL INSTRUCTIONS IN THIS MANUAL AND KEEP FOR FUTURE REFERENCE. IF YOU HAVE ANY QUESTIONS ABOUT THE PRODUCT CALL EVO MANUFACTURING. FAILURE TO FOLLOW GUIDELINES COULD RESULT IN MALFUNCTION OF PARTS OR INJURY. PLEASE HAVE A TRAINED PROFESSIONAL ASSIST WITH OR INSTALL ALL PRODUCTS. INSTALLING EVO MFG PRODUCTS OR KITS DEMANDS SPECIFIC KNOWLEDGE, TOOLS AND EXPERIENCE. GENERAL KNOWLEDGE OF HOW TO USE LATER SPECIFIED TOOLS AND/OR LIMITED EXPERIENCE WITH EVO MFG PRODUCTS MAY NOT BE ENOUGH TO PROPERLY COMPLETE THESE TASKS. SOME OF EVO MFG PRODUCTS MAY REQUIRE TWO OR MORE PEOPLE TO INSTALL SAFELY AND CORRECTLY. DO NOT ATTEMPT ALONE, ALWAYS ENLIST THE HELP OF TRAINED PROFESSIONAL WHEN NEEDED.**

#### **READ BEFORE INSTALL**

##### **Recommended Tools:**

- Socket/Tool set
- Wrenches (English/metric)
- Rubber Mallet/Hammer
- Thread lock



---

**This product is not compatible with Jeep Park Assist Back Up Sensors. (This product will work on park assist equipped vehicles, park assist will be disabled).**

**Unless otherwise stated. Keep all installed bolts loose until all bolts are loosely installed. Then tighten when specified.**





### Safety Steps for installation

- For installing EVO MFG products always use wheel chokes to block rear tires from rolling.
- Always make sure you have everything necessary ready before install.
- If you have to, carefully lift front of vehicle by front frame rails extending suspension until tires leave the ground, place frame on approved jack stands for vehicle. Verify all lines/wires are not over extended.
- Remove tires if needed for easier install.
- Make sure to wear safety equipment (eye protection, hand protection, foot protection etc.) at all times during installation.
- Make sure all safety precautions have been taken.
- Always check and replace any part of vehicle that is worn or broken before starting install.
- Do not mix anything EVO with weaker alternatives.
- It is generally a good idea to apply liquid threadlock to all bolts.
- Tighten included hardware to torque specifications in bottom table unless it is otherwise specified, factory bolts should be torqued to factory Jeep specifications.





- 
1. Follow factory procedures to remove rear bumper from Jeep.
  2. Remove and retain factory bolts on tow hooks both driver and passenger side.





3. With bumper and tow hooks removed. Loosely install Dring Shackle tabs to fascia using the supplied 3/8" bolts on the smaller upper bolts hole. Align the lower 2 holes visually or with removed factory bolts and snug the upper 3/8" bolt, both sides. (it is easily to install this bolt off the vehicle, once installed on vehicle access inside nut is difficult.). Make sure once tight the lower 2 larger bolts holes are aligned, or the fascia will not install the vehicle.



- 
4. Install fascia center plate with 6 supplied button head screws.





5. Insert passenger side flag nut into frame. Align nut on tab over forward hole in bottom of frame and flange through side hole in frame.





6. Install assembled fascia to frame. There is a large variance in frame widths. Tap with a mallet to fascia or hammer to frame sides may be required.
7. Reuse all factory hardware install fascia to frame. 4 bolts (2 on side and 2 from underneath) on driver side, 2 side bolts on passenger side. Use supplied M12 bolt to thread from underside up into supplied/inserted flag nut on passenger side. With all bolts loosely installed. Torque all bolts.





After Install:

- After completing installation using provided instructions, go through all steps again to make sure nothing was missed, not tightened or improperly assembled.
- Some components may need to be purchased separately.
- Make sure all gauges are fully operational.
- Drive the vehicle slowly for a couple minutes, looking and listening for abnormal noises while driving. After modification of a vehicle there will be differences in driving experiences and capabilities, be mindful of that.
- Inspect and Retorque all Bolts after 500 miles of completed installation and regularly thereafter.

**General Recommended Torque Specs:**

Size	Grade 2		Grade 5		Grade 8		18-8 S/S	
	Coarse	Fine	Coarse	Fine	Coarse	Fine	Coarse	Fine
<b>#4*</b>	-	-	-	-	-	-	5.2	-
<b>#6*</b>	-	-	-	-	-	-	9.6	-
<b>#8*</b>	-	-	-	-	-	-	19.8	-
<b>#10*</b>	-	-	-	-	-	-	22.8	31.7
<b>1/4</b>	4	4.7	6.3	7.3	9	10	6.3	7.8
<b>5/16</b>	8	9	13	14	18	20	11	11.8
<b>3/8</b>	15	17	23	26	33	37	20	22
<b>7/16</b>	24	27	37	41	52	58	31	33
<b>1/2</b>	37	41	57	64	80	90	43	45
<b>9/16</b>	53	59	82	91	115	129	57	63
<b>5/8</b>	73	83	112	128	159	180	93	104
<b>3/4</b>	125	138	200	223	282	315	128	124
<b>7/8</b>	129	144	322	355	454	501	194	193



EVO Manufacturing

EVO-3142

**JEEP WRANGLER UNLIMITED JLU ROCKSLIDER STEPS**





Before starting installation procedure please read <http://evomfg.com>Returns-Warranties-Shipping>

---

**CAREFULLY READ COMPLETE MANUAL BEFORE BEGGINNG INSTALLATION**  
**PROCEED ONLY ONCE COMFORTABLE WITH DETAILED PROCEDURES:**

**FOLLOW ALL INSTRUCTIONS IN THIS MANUAL AND KEEP FOR FUTURE REFERENCE. IF YOU HAVE ANY QUESTIONS ABOUT THE PRODUCT CALL EVO MANUFACTURURING. FAILURE TO FOLLOW GUIDELINES COULD RESULT IN MALFUNCTION OF PARTS OR INJURY. PLEASE HAVE A TRAINED PROFESSIONAL ASSIST WITH OR INSTALL ALL PRODUCTS. INSTALLING EVO MFG PRODUCTS OR KITS DEMANDS SPECIFIC KNOWLEDGE, TOOLS AND EXPERIENCE. GENERAL KNOWLEDGE OF HOW TO USE LATER SPECIFIED TOOLS AND/OR LIMITED EXPERIENCE WITH EVO MFG PRODUCTS MAY NOT BE ENOUGH TO PROPERLY COMPLETE THESE TASKS. SOME OF EVO MFG PRODUCTS MAY REQUIRE TWO OR MORE PEOPLE TO INSTALL SAFELY AND CORRECTLY. DO NOT ATTEMPT ALONE, ALWAYS ENLIST THE HELP OF TRAINED PROFESSIONAL WHEN NEEDED.**

**General Recommended Tools/Supplies:**

- Socket/Tool set (SAE/Metric)
- Wrenches (SAE/metric)
- Allen Wrench set (SAE)
- Rubber Mallet/Hammer
- Thread lock
- Drill with metal bits (if bolting on)
- Skilled Welder and protective gear (if welding on)
- Vice grip plyers
- Grinder
- Black touch up paint
- Medium thread locker liquid
- Safety glasses and other safety equipment
- Center Punch/Transfer Punch and Hammer



---

**Unless otherwise stated. Keep all installed bolts LOOSE until ALL bolts are loosely installed in the component part. Then tighten when specified. Tightening individual bolts in a component before all bolts are installed in that component will make further bolt install difficult/impossible.**





Rock Light Kit: If Rock lights were optioned. This is wire yourself product. We do not have installation instructions for this procedure and additional parts will be required/no supplied. Install should be performed by a trained and knowledgeable professional using Factory standard level materials.

Safety Steps for installation

- For installing EVO MFG products always use wheel chokes to block rear tires from rolling.
- Always make sure you have everything necessary ready before install.
- If you have to, carefully lift front of vehicle by front frame rails extending suspension until tires leave the ground, place frame on approved jack stands for vehicle. Verify all lines/wires are not over extended.
- Remove tires if needed for easier install.
- Make sure to wear safety equipment (eye protection, hand protection, foot protection etc.) at all times during installation.
- Make sure all safety precautions have been taken.
- Always check and replace any part of vehicle that is worn or broken before starting install.
- Do not mix anything EVO with weaker alternatives.
- It is generally a good idea to apply liquid threadlock to all bolts.
- Tighten included hardware to torque specifications in bottom table unless it is otherwise specified, factory bolts should be torqued to factory Jeep specifications.





---

1. Follow factory procedures to remove any installed steps of sliders from the vehicle, both sides.

2. Begin installation by grinding flat the flared edge on BOTH sides of the middle body mount.



3. Paint exposed metal





**SLIDER ASSEMBLY: Depending on optioned sliders components, some or all of the below procedures may apply**

2 Pairs of Slider End Caps (left and right) Supplied. With nut clips.



End Plate Assembly: With a firm push, press on nut clips to Slider End Caps over the 4 holes of each part. Barrell section of nut clip should be on the inside of the part all 4 places. Center clip thread over holes.



Lighting. Insert light wire through hole in end cap. Install light to bracket using supplied M4 bolts.





Insert end caps into slider ends. This can be a tight fit. Wiring should be positioned out bottom corner of end cap as shown. Use Supplied ¼" button head bolts front and back of each end of sliders 8 per slider (omit back side bolts if installing step plates)





Slider Step Plates. Install 2 nut clip over holes on center mount side tabs. Barrel side inside bracket. Install Center Mount to Step Plate with supplied M5 bolts in light kit or in EVO-770103 end cap hardware kit. If installing 3<sup>rd</sup> middle light, install light on top of support plate. Position on the back side of slider as shown. Use remaining supplied ¼" button head bolts to secure.





---

Remove Factory M12 bolts from the underside of the frame. 1 near the forward body mount and 2/3 near middle body mount (this may vary between models). Bolts will be reused.

**Additional nearby bolts on gas tank skid and other skid plates may need to be carefully loosened (not removed) to lower skid plates and gas tank slightly to install/insert sliders. DO SO AS NEEDED**





With the specified bolts removed.

If welding: Prep any painted edges as needed (sand/remove paint) in areas that will be welded on part before bringing to vehicle for install.

Lift and install slider into place on frame. This may require 2 or more people. Middle and Rear Frame Extension will straddle the previously grinded edge middle body mount, surrounding it on both sides.

**Key Note:**

**Slider frame plates must be installed between the frame and all factory skid plate tabs and gas tank tabs. Slider sandwiches between these. NOT ON TOP OF THEM. Loosen other nearby bolts to lower skids as needed.**









Press slider up towards frame to fully seat against it. Install the removed factory bolts back into their original bolting locations. Snug bolts (Will be removed again later).

---

**Bolting On:**

With sliders in place with factory hardware on lower side of frame installed and snug.

Using supplied short nut plate (vice grip style plyers may help extend grip as shown). Install into large rear hole near rear mounting location. Install supplied 7/16" hardware with washers into nut plate at rear hole. Snug Bolt.





With slider installed and rear nut plates snugged (pulling slider up and tight to frame). Lift/Jack Slider up if needed to be against frame side. Do not mark holes until slider is up and against frame as intended for final install. Mark all to be drilled holes with marker/paint pen. On the forward foot, there is one on the body mount and one on the frame. On the middle/rear foot, there is one on each side of the body mount. 4 drill holes per side in total.









Remove the factory hardware installed on the underside of the frame and the 2 installed nut plate, use vice grip/hold tab on nut plates before bolt removal to prevent tab from falling into frame. Remove slider from vehicle.

Center punch the center of all hard holes.





The final drill size of all drilled holes 15/32"-1/2" drill bit. Start with smaller drill on all holes and then step drill size up to final size. Drill all 4 marked/center punched holes.











Reinstall slider. May require 2 or more people to insert into place.

Loosely reinstall the Factory M12 bolts to underside of frame through slider and all skid plates.

Loosely install supplied 7/16" bolts, washers and nuts into 3 drilled body mount holes.

Loosely install forward and rear nut plates with supplied 7/16" hardware. (use of medium thread locker suggested).









With all bolts in part installed. Tighten all bolts to factory (factory bolts) and Recommended (supplied bolts) in table.





If Welding: This should be performed by a skill and trained professional installer. Verify no wiring, coolant lines or other delicate components are in the way, near, around or inside the areas of welding before welding.

Remove all battery connections before welding. Use a good grounding near weld application. Dropping/Removal of gas tank is suggested for safety. Consult your repair manual on proper procedure to do so.

With slider installed using factory lower frame bolts. Lift/jack/clamp Slider up into place tight against frame surfaces. Verify appropriate positioning before proceeding.

Weld all prepped areas/connection with frame and body mounts. Primarily all frame side vertical connections.

Paint all welded areas.

Reconnect/install gas tank and battery cable per your repair manual procedure.

After Install:

- After completing installation using provided instructions, go through all steps again to make sure nothing was missed, not tightened or improperly assembled.
- Some components may need to be purchased separately.
- Make sure all gauges are fully operational.
- Drive the vehicle slowly for a couple minutes, looking and listening for abnormal noises while driving. After modification of a vehicle there will be differences in driving experiences and capabilities, be mindful of that.
- Inspect and Retorque all Bolts after 500 miles of completed installation and regularly thereafter.



General Recommended Torque Specs: Usual Supplied Hardware from EVO MFG is Grade 8 Fine.

Size	Grade 2		Grade 5		Grade 8		18-8 S/S	
	Coarse	Fine	Coarse	Fine	Coarse	Fine	Coarse	Fine
#4*	-	-	-	-	-	-	5.2	-
#6*	-	-	-	-	-	-	9.6	-
#8*	-	-	-	-	-	-	19.8	-
#10*	-	-	-	-	-	-	22.8	31.7
1/4	4	4.7	6.3	7.3	9	10	6.3	7.8
5/16	8	9	13	14	18	20	11	11.8
3/8	15	17	23	26	33	37	20	22
7/16	24	27	37	41	52	58	31	33
1/2	37	41	57	64	80	90	43	45
9/16	53	59	82	91	115	129	57	63
5/8	73	83	112	128	159	180	93	104
3/4	125	138	200	223	282	315	128	124
7/8	129	144	322	355	454	501	194	193



EVO Manufacturing

EVO-3142

**JEEP WRANGLER UNLIMITED JLU ROCKSLIDER STEPS**







Before starting installation procedure please read <http://evomfg.com>Returns-Warranties-Shipping>

---

**CAREFULLY READ COMPLETE MANUAL BEFORE BEGGINNG INSTALLATION**  
**PROCEED ONLY ONCE COMFORTABLE WITH DETAILED PROCEDURES:**

**FOLLOW ALL INSTRUCTIONS IN THIS MANUAL AND KEEP FOR FUTURE REFERENCE. IF YOU HAVE ANY QUESTIONS ABOUT THE PRODUCT CALL EVO MANUFACTURURING. FAILURE TO FOLLOW GUIDELINES COULD RESULT IN MALFUNCTION OF PARTS OR INJURY. PLEASE HAVE A TRAINED PROFESSIONAL ASSIST WITH OR INSTALL ALL PRODUCTS. INSTALLING EVO MFG PRODUCTS OR KITS DEMANDS SPECIFIC KNOWLEDGE, TOOLS AND EXPERIENCE. GENERAL KNOWLEDGE OF HOW TO USE LATER SPECIFIED TOOLS AND/OR LIMITED EXPERIENCE WITH EVO MFG PRODUCTS MAY NOT BE ENOUGH TO PROPERLY COMPLETE THESE TASKS. SOME OF EVO MFG PRODUCTS MAY REQUIRE TWO OR MORE PEOPLE TO INSTALL SAFELY AND CORRECTLY. DO NOT ATTEMPT ALONE, ALWAYS ENLIST THE HELP OF TRAINED PROFESSIONAL WHEN NEEDED.**

**General Recommended Tools/Supplies:**

- Socket/Tool set (SAE/Metric)
- Wrenches (SAE/metric)
- Allen Wrench set (SAE)
- Rubber Mallet/Hammer
- Thread lock
- Drill with metal bits (if bolting on)
- Skilled Welder and protective gear (if welding on)
- Vice grip plyers
- Grinder
- Black touch up paint
- Medium thread locker liquid
- Safety glasses and other safety equipment
- Center Punch/Transfer Punch and Hammer



---

**Unless otherwise stated. Keep all installed bolts LOOSE until ALL bolts are loosely installed in the component part. Then tighten when specified. Tightening individual bolts in a component before all bolts are installed in that component will make further bolt install difficult/impossible.**



Rock Light Kit: If Rock lights were optioned. This is wire yourself product. We do not have installation instructions for this procedure and additional parts will be required/no supplied. Install should be performed by a trained and knowledgeable professional using Factory standard level materials.

Safety Steps for installation

- For installing EVO MFG products always use wheel chokes to block rear tires from rolling.
- Always make sure you have everything necessary ready before install.
- If you have to, carefully lift front of vehicle by front frame rails extending suspension until tires leave the ground, place frame on approved jack stands for vehicle. Verify all lines/wires are not over extended.
- Remove tires if needed for easier install.
- Make sure to wear safety equipment (eye protection, hand protection, foot protection etc.) at all times during installation.
- Make sure all safety precautions have been taken.
- Always check and replace any part of vehicle that is worn or broken before starting install.
- Do not mix anything EVO with weaker alternatives.
- It is generally a good idea to apply liquid threadlock to all bolts.
- Tighten included hardware to torque specifications in bottom table unless it is otherwise specified, factory bolts should be torqued to factory Jeep specifications.





---

1. Follow factory procedures to remove any installed steps of sliders from the vehicle, both sides.

2. Begin installation by grinding flat the flared edge on BOTH sides of the middle body mount.



3. Paint exposed metal





**SLIDER ASSEMBLY: Depending on optioned sliders components, some or all of the below procedures may apply**

2 Pairs of Slider End Caps (left and right) Supplied. With nut clips.



End Plate Assembly: With a firm push, press on nut clips to Slider End Caps over the 4 holes of each part. Barrell section of nut clip should be on the inside of the part all 4 places. Center clip thread over holes.



Lighting. Insert light wire through hole in end cap. Install light to bracket using supplied M4 bolts.





Insert end caps into slider ends. This can be a tight fit. Wiring should be positioned out bottom corner of end cap as shown. Use Supplied ¼" button head bolts front and back of each end of sliders 8 per slider (omit back side bolts if installing step plates)





Slider Step Plates. Install 2 nut clip over holes on center mount side tabs. Barrel side inside bracket. Install Center Mount to Step Plate with supplied M5 bolts in light kit or in EVO-770103 end cap hardware kit. If installing 3<sup>rd</sup> middle light, install light on top of support plate. Position on the back side of slider as shown. Use remaining supplied ¼" button head bolts to secure.





---

Remove Factory M12 bolts from the underside of the frame. 1 near the forward body mount and 2/3 near middle body mount (this may vary between models). Bolts will be reused.

**Additional nearby bolts on gas tank skid and other skid plates may need to be carefully loosened (not removed) to lower skid plates and gas tank slightly to install/insert sliders. DO SO AS NEEDED**





With the specified bolts removed.

If welding: Prep any painted edges as needed (sand/remove paint) in areas that will be welded on part before bringing to vehicle for install.

Lift and install slider into place on frame. This may require 2 or more people. Middle and Rear Frame Extension will straddle the previously grinded edge middle body mount, surrounding it on both sides.

**Key Note:**

**Slider frame plates must be installed between the frame and all factory skid plate tabs and gas tank tabs. Slider sandwiches between these. NOT ON TOP OF THEM. Loosen other nearby bolts to lower skids as needed.**









Press slider up towards frame to fully seat against it. Install the removed factory bolts back into their original bolting locations. Snug bolts (Will be removed again later).

---

**Bolting On:**

With sliders in place with factory hardware on lower side of frame installed and snug.

Using supplied short nut plate (vice grip style plyers may help extend grip as shown). Install into large rear hole near rear mounting location. Install supplied 7/16" hardware with washers into nut plate at rear hole. Snug Bolt.





With slider installed and rear nut plates snugged (pulling slider up and tight to frame). Lift/Jack Slider up if needed to be against frame side. Do not mark holes until slider is up and against frame as intended for final install. Mark all to be drilled holes with marker/paint pen. On the forward foot, there is one on the body mount and one on the frame. On the middle/rear foot, there is one on each side of the body mount. 4 drill holes per side in total.









Remove the factory hardware installed on the underside of the frame and the 2 installed nut plate, use vice grip/hold tab on nut plates before bolt removal to prevent tab from falling into frame. Remove slider from vehicle.

Center punch the center of all hard holes.





The final drill size of all drilled holes 15/32"-1/2" drill bit. Start with smaller drill on all holes and then step drill size up to final size. Drill all 4 marked/center punched holes.











Reinstall slider. May require 2 or more people to insert into place.

Loosely reinstall the Factory M12 bolts to underside of frame through slider and all skid plates.

Loosely install supplied 7/16" bolts, washers and nuts into 3 drilled body mount holes.

Loosely install forward and rear nut plates with supplied 7/16" hardware. (use of medium thread locker suggested).









With all bolts in part installed. Tighten all bolts to factory (factory bolts) and Recommended (supplied bolts) in table.





If Welding: This should be performed by a skill and trained professional installer. Verify no wiring, coolant lines or other delicate components are in the way, near, around or inside the areas of welding before welding.

Remove all battery connections before welding. Use a good grounding near weld application. Dropping/Removal of gas tank is suggested for safety. Consult your repair manual on proper procedure to do so.

With slider installed using factory lower frame bolts. Lift/jack/clamp Slider up into place tight against frame surfaces. Verify appropriate positioning before proceeding.

Weld all prepped areas/connection with frame and body mounts. Primarily all frame side vertical connections.

Paint all welded areas.

Reconnect/install gas tank and battery cable per your repair manual procedure.

After Install:

- After completing installation using provided instructions, go through all steps again to make sure nothing was missed, not tightened or improperly assembled.
- Some components may need to be purchased separately.
- Make sure all gauges are fully operational.
- Drive the vehicle slowly for a couple minutes, looking and listening for abnormal noises while driving. After modification of a vehicle there will be differences in driving experiences and capabilities, be mindful of that.
- Inspect and Retorque all Bolts after 500 miles of completed installation and regularly thereafter.



General Recommended Torque Specs: Usual Supplied Hardware from EVO MFG is Grade 8 Fine.

Size	Grade 2		Grade 5		Grade 8		18-8 S/S	
	Coarse	Fine	Coarse	Fine	Coarse	Fine	Coarse	Fine
#4*	-	-	-	-	-	-	5.2	-
#6*	-	-	-	-	-	-	9.6	-
#8*	-	-	-	-	-	-	19.8	-
#10*	-	-	-	-	-	-	22.8	31.7
1/4	4	4.7	6.3	7.3	9	10	6.3	7.8
5/16	8	9	13	14	18	20	11	11.8
3/8	15	17	23	26	33	37	20	22
7/16	24	27	37	41	52	58	31	33
1/2	37	41	57	64	80	90	43	45
9/16	53	59	82	91	115	129	57	63
5/8	73	83	112	128	159	180	93	104
3/4	125	138	200	223	282	315	128	124
7/8	129	144	322	355	454	501	194	193





EVO Manufacturing  
Jeep Wrangler JL and JT Gladiator  
JL/JT Rock Skin Instruction  
EVO-3146/3147





Before starting installation procedure please read <http://evomfg.com>Returns-Warranties-Shipping>

**CAREFULLY READ AND FOLLOW ALL INSTRUCTIONS IN THIS MANUAL AND KEEP FOR FUTURE REFERENCE. IF YOU HAVE ANY QUESTIONS ABOUT THE PRODUCT CALL EVO MANUFACTURING. FAILURE TO FOLLOW GUIDELINES COULD RESULT IN MALFUNCTION OF PARTS OR INJURY. PLEASE HAVE A TRAINED PROFESSIONAL ASSIST WITH OR INSTALL ALL PRODUCTS. INSTALLING EVO MFG PRODUCTS OR KITS DEMANDS SPECIFIC KNOWLEDGE, TOOLS AND EXPERIENCE. GENERAL KNOWLEDGE OF HOW TO USE LATER SPECIFIED TOOLS AND/OR LIMITED EXPERIENCE WITH EVO MFG PRODUCTS MAY NOT BE ENOUGH TO PROPERLY COMPLETE THESE TASKS. SOME OF EVO MFG PRODUCTS MAY REQUIRE TWO OR MORE PEOPLE TO INSTALL SAFELY AND CORRECTLY. DO NOT ATTEMPT ALONE, ALWAYS ENLIST THE HELP OF TRAINED PROFESSIONAL WHEN NEEDED.**

**Notes: Set Up Before installation**

**May need 2/3 people to apply to vehicle.**

**READ BEFORE INSTALL:** General Notes

It is generally a good idea to apply Loctite to all threaded bolts.  
ALWAYS wear safety glasses and other approved safety gear when working on a vehicle.  
All supplied bolts torqued according to chart at end of instruction.  
It is recommended all installation be performed by a trained professional. Some modification may have to be done.  
Paint all unfinished surfaces after install is complete.

**Parts included:**

**EVO-3146ALH / B**

Description	Part # AL	Quantity
JLU Driver Side Adhesive Skin	EVO-12567AL / B	1
JLU Driver Side Adhesive Skin	EVO-12568AL / B	1
Adhesive Roll	EVO-600139	1

**EVO-3147ALH / B**

Description	Part # AL	Quantity
GLAD Driver Side Adhesive Skin	EVO-12569AL / B	1
GLAD Driver Side Adhesive Skin	EVO-12570AL / B	1
Adhesive Roll	EVO-600139	2



#### **Recommended Tools:**

- Razor Blade (if Adhesive Skin)
  - Clean Rag and Glass Cleaner
- 



#### **Safety Steps for installation**

- For installing EVO MFG products always use wheel chokes to block rear tires from rolling.
  - Always make sure you have everything necessary ready before install.
  - If you have to, carefully lift front of vehicle by front frame rails extending suspension until tires leave the ground, place frame on approved jack stands for vehicle. Verify all lines/wires are not over extended.
  - Remove tires if needed for easier install.
  - Make sure to wear safety equipment (eye protection, hand protection, foot protection etc.) at all times during installation.
  - Make sure all safety precautions have been taken.
  - Always check and replace any part of vehicle that is worn or broken before starting install.
  - Do not mix anything EVO with weaker alternatives.
  - It is generally a good idea to apply liquid threadlock to all bolts.
  - Tighten included hardware to torque specifications in bottom table unless it is otherwise specified, factory bolts should be torqued to factory Jeep specifications.
- 





### **Adhesive INSTALL:**

**Images shown of Gladiator. JLU follow same procedure**

Safely park car on flat ground, put in park and chock wheels.

#### **VERY IMPORTANT NOTE BELOW:**

#### **READ AND UNDERSTAND BEFORE INSTALL**

THE ADHESIVE SUPPLIED FOR THIS PART IS AUTOMOTIVE GRADE PRODUCT THAT IS RATED AT “VERY HIGH BOND”. THIS IS VERY DIFFICULT TO REMOVE AFTER INSTALLATION AND SHOULD BE CONSIDERED RELATIVELY PERIMANENT ONCE PART IS IN CONTACT WITH BODY.

REMOVAL MAY CAUSE DAMAGE TO PAINT/BODY.

ONLY PROCEED WITH INSTALLATION IF CONFIDENT WITH YOUR SKILLS AND KNOWN RISKS.



1. Remove any steps, sliders, rails etc. from vehicle allowing for unobstructed body panel to be accessed.
  2. Using paint suitable rag and cleaner. Thoroughly clean body panel surface where skin is to be applied.
  3. Likely will need the assistance of additional people. Hold skin up to vehicle and get a reference before install of where the part will lie. Note part offset from body lines etc.
- 

4. Using rag, clean part back surface. Install supplied adhesive from roll as shown on perimeter of Skins. Apply on side to be in contact with vehicle body. May need to apply adhesive in multiple parted pieces. Use Razer Blade to part and trim adhesive as needed.
- 





5. Remove Backing from applied Adhesive



---

.....

**Time to adhere to vehicle body. This will create a near permanent bond. There are no redo's.**

.....

---



6. As in previous step with the help of additional people. Carefully and skillfully install part with adhesive to vehicle body noting body to part lines. It may be best to adhere the center and then work towards the ends front and back.



After Install General Notes:

- Tighten all bolts securing purchased parts to specified locations.
- After completing installation using provided instructions, go through all steps again to make sure nothing was missed, not tightened or improperly assembled.
- Some components may need to be purchased separately.
- Check turn signals, headlights, fog lights (if applicable), taillights, blinkers and windshield wipers.
- Adjust mirrors, speedometer and headlights if needed.
- Make sure all gauges are fully operational.
- Drive the vehicle slowly for a couple minutes, looking and listening for abnormal noises while driving. After modification of a vehicle there will be differences in driving experiences and capabilities, be mindful of that.
- Inspect and Retorque all Bolts after 500 miles of completed installation and regularly thereafter.
- Some modification may be required.



Recommended Torque:

Size	Grade 2		Grade 5		Grade 8		18-8 S/S	
	Coarse	Fine	Coarse	Fine	Coarse	Fine	Coarse	Fine
<b>#4*</b>	-	-	-	-	-	-	5.2	-
<b>#6*</b>	-	-	-	-	-	-	9.6	-
<b>#8*</b>	-	-	-	-	-	-	19.8	-
<b>#10*</b>	-	-	-	-	-	-	22.8	31.7
<b>1/4</b>	4	4.7	6.3	7.3	9	10	6.3	7.8
<b>5/16</b>	8	9	13	14	18	20	11	11.8
<b>3/8</b>	15	17	23	26	33	37	20	22
<b>7/16</b>	24	27	37	41	52	58	31	33
<b>1/2</b>	37	41	57	64	80	90	43	45
<b>9/16</b>	53	59	82	91	115	129	57	63
<b>5/8</b>	73	83	112	128	159	180	93	104
<b>3/4</b>	125	138	200	223	282	315	128	124
<b>7/8</b>	129	144	322	355	454	501	194	193
<b>1†</b>	188	210	483	541	682	764	287	289





EVO Manufacturing  
Jeep Wrangler JL and JT Gladiator  
JL/JT Rock Skin Instruction  
EVO-3146/3147





Before starting installation procedure please read <http://evomfg.com>Returns-Warranties-Shipping>

**CAREFULLY READ AND FOLLOW ALL INSTRUCTIONS IN THIS MANUAL AND KEEP FOR FUTURE REFERENCE. IF YOU HAVE ANY QUESTIONS ABOUT THE PRODUCT CALL EVO MANUFACTURING. FAILURE TO FOLLOW GUIDELINES COULD RESULT IN MALFUNCTION OF PARTS OR INJURY. PLEASE HAVE A TRAINED PROFESSIONAL ASSIST WITH OR INSTALL ALL PRODUCTS. INSTALLING EVO MFG PRODUCTS OR KITS DEMANDS SPECIFIC KNOWLEDGE, TOOLS AND EXPERIENCE. GENERAL KNOWLEDGE OF HOW TO USE LATER SPECIFIED TOOLS AND/OR LIMITED EXPERIENCE WITH EVO MFG PRODUCTS MAY NOT BE ENOUGH TO PROPERLY COMPLETE THESE TASKS. SOME OF EVO MFG PRODUCTS MAY REQUIRE TWO OR MORE PEOPLE TO INSTALL SAFELY AND CORRECTLY. DO NOT ATTEMPT ALONE, ALWAYS ENLIST THE HELP OF TRAINED PROFESSIONAL WHEN NEEDED.**

**Notes: Set Up Before installation**

**May need 2/3 people to apply to vehicle.**

**READ BEFORE INSTALL:** General Notes

It is generally a good idea to apply Loctite to all threaded bolts.  
ALWAYS wear safety glasses and other approved safety gear when working on a vehicle.  
All supplied bolts torqued according to chart at end of instruction.  
It is recommended all installation be performed by a trained professional. Some modification may have to be done.  
Paint all unfinished surfaces after install is complete.

**Parts included:**

**EVO-3146ALH / B**

Description	Part # AL	Quantity
JLU Driver Side Adhesive Skin	EVO-12567AL / B	1
JLU Driver Side Adhesive Skin	EVO-12568AL / B	1
Adhesive Roll	EVO-600139	1

**EVO-3147ALH / B**

Description	Part # AL	Quantity
GLAD Driver Side Adhesive Skin	EVO-12569AL / B	1
GLAD Driver Side Adhesive Skin	EVO-12570AL / B	1
Adhesive Roll	EVO-600139	2



**Recommended Tools:**

- Razor Blade (if Adhesive Skin)
  - Clean Rag and Glass Cleaner
- 



Safety Steps for installation

- For installing EVO MFG products always use wheel chokes to block rear tires from rolling.
  - Always make sure you have everything necessary ready before install.
  - If you have to, carefully lift front of vehicle by front frame rails extending suspension until tires leave the ground, place frame on approved jack stands for vehicle. Verify all lines/wires are not over extended.
  - Remove tires if needed for easier install.
  - Make sure to wear safety equipment (eye protection, hand protection, foot protection etc.) at all times during installation.
  - Make sure all safety precautions have been taken.
  - Always check and replace any part of vehicle that is worn or broken before starting install.
  - Do not mix anything EVO with weaker alternatives.
  - It is generally a good idea to apply liquid threadlock to all bolts.
  - Tighten included hardware to torque specifications in bottom table unless it is otherwise specified, factory bolts should be torqued to factory Jeep specifications.
- 





### **Adhesive INSTALL:**

**Images shown of Gladiator. JLU follow same procedure**

Safely park car on flat ground, put in park and chock wheels.

#### **VERY IMPORTANT NOTE BELOW:**

#### **READ AND UNDERSTAND BEFORE INSTALL**

THE ADHESIVE SUPPLIED FOR THIS PART IS AUTOMOTIVE GRADE PRODUCT THAT IS RATED AT “VERY HIGH BOND”. THIS IS VERY DIFFICULT TO REMOVE AFTER INSTALLATION AND SHOULD BE CONSIDERED RELATIVELY PERIMANENT ONCE PART IS IN CONTACT WITH BODY.

REMOVAL MAY CAUSE DAMAGE TO PAINT/BODY.

ONLY PROCEED WITH INSTALLATION IF CONFIDENT WITH YOUR SKILLS AND KNOWN RISKS.



1. Remove any steps, sliders, rails etc. from vehicle allowing for unobstructed body panel to be accessed.
  2. Using paint suitable rag and cleaner. Thoroughly clean body panel surface where skin is to be applied.
  3. Likely will need the assistance of additional people. Hold skin up to vehicle and get a reference before install of where the part will lie. Note part offset from body lines etc.
- 

4. Using rag, clean part back surface. Install supplied adhesive from roll as shown on perimeter of Skins. Apply on side to be in contact with vehicle body. May need to apply adhesive in multiple parted pieces. Use Razer Blade to part and trim adhesive as needed.
- 





- 5. Remove Backing from applied Adhesive



---

.....

**Time to adhere to vehicle body. This will create a near permanent bond. There are no redo's.**

.....

---



6. As in previous step with the help of additional people. Carefully and skillfully install part with adhesive to vehicle body noting body to part lines. It may be best to adhere the center and then work towards the ends front and back.



After Install General Notes:

- Tighten all bolts securing purchased parts to specified locations.
- After completing installation using provided instructions, go through all steps again to make sure nothing was missed, not tightened or improperly assembled.
- Some components may need to be purchased separately.
- Check turn signals, headlights, fog lights (if applicable), taillights, blinkers and windshield wipers.
- Adjust mirrors, speedometer and headlights if needed.
- Make sure all gauges are fully operational.
- Drive the vehicle slowly for a couple minutes, looking and listening for abnormal noises while driving. After modification of a vehicle there will be differences in driving experiences and capabilities, be mindful of that.
- Inspect and Retorque all Bolts after 500 miles of completed installation and regularly thereafter.
- Some modification may be required.



Recommended Torque:

Size	Grade 2		Grade 5		Grade 8		18-8 S/S	
	Coarse	Fine	Coarse	Fine	Coarse	Fine	Coarse	Fine
<b>#4*</b>	-	-	-	-	-	-	5.2	-
<b>#6*</b>	-	-	-	-	-	-	9.6	-
<b>#8*</b>	-	-	-	-	-	-	19.8	-
<b>#10*</b>	-	-	-	-	-	-	22.8	31.7
<b>1/4</b>	4	4.7	6.3	7.3	9	10	6.3	7.8
<b>5/16</b>	8	9	13	14	18	20	11	11.8
<b>3/8</b>	15	17	23	26	33	37	20	22
<b>7/16</b>	24	27	37	41	52	58	31	33
<b>1/2</b>	37	41	57	64	80	90	43	45
<b>9/16</b>	53	59	82	91	115	129	57	63
<b>5/8</b>	73	83	112	128	159	180	93	104
<b>3/4</b>	125	138	200	223	282	315	128	124
<b>7/8</b>	129	144	322	355	454	501	194	193
<b>1†</b>	188	210	483	541	682	764	287	289





EVO Manufacturing

Jeep Wrangler JL

Rear Inner Fender Liner

EVO-3159

Before starting installation procedure please read <http://evomfg.com>Returns-Warranties-Shipping>

---

**CAREFULLY READ AND FOLLOW ALL INSTRUCTIONS IN THIS MANUAL AND KEEP FOR FUTURE REFERENCE. IF YOU HAVE ANY QUESTIONS ABOUT THE PRODUCT CALL EVO MANUFACTURING. FAILURE TO FOLLOW GUIDELINES COULD RESULT IN MALFUNCTION OF PARTS OR INJURY. PLEASE HAVE A TRAINED PROFESSIONAL ASSIST WITH OR INSTALL ALL PRODUCTS. INSTALLING EVO MFG PRODUCTS OR KITS DEMANDS SPECIFIC KNOWLEDGE, TOOLS AND EXPERIENCE. GENERAL KNOWLEDGE OF HOW TO USE LATER SPECIFIED TOOLS AND/OR LIMITED EXPERIENCE WITH EVO MFG PRODUCTS MAY NOT BE ENOUGH TO PROPERLY COMPLETE THESE TASKS. SOME OF EVO MFG PRODUCTS MAY REQUIRE TWO OR MORE PEOPLE TO INSTALL SAFELY AND CORRECTLY. DO NOT ATTEMPT ALONE, ALWAYS ENLIST THE HELP OF TRAINED PROFESSIONAL WHEN NEEDED.**



**Notes: Set Up Before installation**

**These instructions involve how to install Inner Liners with factory fenders.**

**This installation process will vary with aftermarket fenders.**

**If installing with aftermarket fenders work around these steps to install.**

**Inner fenders must mount to all body connections directly and then install all other fender parts or supports to the inner fender section. Sandwiching inner fenders between.**

**Do not mount inner fenders to outside of other parts.**

**Some adjustments may be needed to secure liner properly per individual vehicle setup.**

**Keep all mounting bolts loose (installed but not torqued) we will torque later at the end of complete installation**

**READ BEFORE INSTALL:**

It is generally a good idea to apply Loctite to all threaded bolts.

ALWAYS wear safety glasses and other approved safety gear when working on a vehicle.

All supplied bolts torqued according to chart at end of instruction.

It is recommended all installation be performed by a trained professional. Some modification may have to be done.

Paint all unfinished surfaces after install is complete if preferred.

**Recommended Tools:**

- Allen set
  - Wrench with standard sockets
  - Drill and with bits
  - Plastic fastener clip removal tool
- 





### Safety Steps for installation

- For installing EVO MFG products always use wheel chokes to block rear tires from rolling.
  - Always make sure you have everything necessary ready before install.
  - If you have to, carefully lift front of vehicle by front frame rails extending suspension until tires leave the ground, place frame on approved jack stands for vehicle. Verify all lines/wires are not over extended.
  - Remove tires if needed for easier install.
  - Make sure to wear safety equipment (eye protection, hand protection, foot protection etc.) at all times during installation.
  - Make sure all safety precautions have been taken.
  - Always check and replace any part of vehicle that is worn or broken before starting install.
  - Do not mix anything EVO with weaker alternatives.
  - It is generally a good idea to apply liquid thread lock to all bolts.
  - Tighten included hardware to torque specifications in bottom table unless it is otherwise specified, factory bolts should be torqued to factory Jeep specifications.
- 





## **INSTALL: LEFT AND RIGHT SIDE PRODUCES ARE SAME**

**\*Pictures are for reference only, product may vary. \***

Remove stock liner.  
This can be done by either drilling out the rivets or by pushing on liner at each rivet location. Remove/pull clips from liner on the inner surface at body.





---

Remove the fender clips.  
Clips on the top of the fender and 1 on  
the rear.  
These are multi piece clips, all of the clips  
need to be removed. 3 on each side of  
vehicle.

---





Additionally, clip/remove the 1 clip as shown.





Assemble Liners as shown with supplied #10 screws and nuts.

\*Left and right panels first onto main large panel. Then middle panel on top.

Install Supplied Clip nuts to the 3 circled locations. Barrel end of clip nut should be on back side towards the vehicles body.

---



Before installing to vehicle, rotate clips as shown and use supplied 1/4" screw to center clips in holes making sure bolt will thread.





Install Liner to vehicle as shown. Thread in the 3 supplied 1/4" screws with washer to the 3 clip nut locations.



Center Mark forward mounting how and drill with 9/32 drill.







Mask and Paint drilled hole.  
Wait appropriate time to dry



---

Install supplied  $\frac{1}{4}$ " screw with washer and nut on the forward drilled hole.

---





Repeat all steps on opposite side.

After Install:

- Tighten all bolts securing purchased parts to specified locations.
- After completing installation using provided instructions, go through all steps again to make sure nothing was missed, not tightened or improperly assembled.
- Some components may need to be purchased separately.
- Check turn signals, headlights, fog lights (if applicable), taillights, blinkers and windshield wipers.
- Adjust mirrors, speedometer and headlights if needed.
- Make sure all gauges are fully operational.
- Drive the vehicle slowly for a couple minutes, looking and listening for abnormal noises while driving. After modification of a vehicle there will be differences in driving experiences and capabilities, be mindful of that.
- Inspect and Retorque all Bolts after 500 miles of completed installation and regularly thereafter.
- Some modification may be required.

Recommended Torque: Ft/Lb \*In/Lb

Size	Grade 2		Grade 5		Grade 8		18-8 S/S	
	Coarse	Fine	Coarse	Fine	Coarse	Fine	Coarse	Fine
#4*	-	-	-	-	-	-	5.2 In	-
#6*	-	-	-	-	-	-	9.6 In	-
#8*	-	-	-	-	-	-	19.8 In	-
#10*	-	-	-	-	-	-	22.8 In	31.7
1/4	4	4.7	6.3	7.3	9	10	6.3	7.8
5/16	8	9	13	14	18	20	11	11.8
3/8	15	17	23	26	33	37	20	22
7/16	24	27	37	41	52	58	31	33
1/2	37	41	57	64	80	90	43	45
9/16	53	59	82	91	115	129	57	63
5/8	73	83	112	128	159	180	93	104
3/4	125	138	200	223	282	315	128	124
7/8	129	144	322	355	454	501	194	193
1†	188	210	483	541	682	764	287	289



## EVO Manufacturing

### EVO-3171 JL/JT FRONT STEERING CORRECTION



\* This product offers 2 trackbar mounting locations. One can be used to correct steering and center axle after lifting with stock length trackbar, the other can be used with aftermarket adjustable trackbar. This extended location will require a trackbar that can safely reach ~34.25+”. Verify with your trackbar manufacturer.

Before starting installation procedure please read <http://evomfg.com>Returns-Warranties-Shipping>



## READ BEFORE INSTALL

### Recommended Tools:

- Socket/Tool set
- Wrenches (English/metric)
- Grinder with Flap disk
- Thread lock
- Black Spray Paint
- Drill with bits, Step Drill recommended



---

### Safety Steps for installation

- For installing EVO MFG products always use wheel chokes to block rear tires from rolling.
- Always make sure you have everything necessary ready before install.
- If you have to, carefully lift front of vehicle by front frame rails extending suspension until tires leave the ground, place frame on approved jack stands for vehicle. Verify all lines/wires are not over extended.
- Remove tires if needed for easier install.
- Make sure to wear safety equipment (eye protection, hand protection, foot protection etc.) at all times during installation.
- Make sure all safety precautions have been taken.
- Always check and replace any part of vehicle that is worn or broken before starting install.
- Do not mix anything EVO with weaker alternatives.
- It is generally a good idea to apply liquid threadlock to all bolts.
- Tighten included hardware to torque specifications in bottom table unless it is otherwise specified, factory bolts should be torqued to factory Jeep specifications.



1. Park vehicle safely and securely on level ground.



2. Remove bolt holding front trackbar at axle.





- 
3. Remove Passenger side Lower sway bar mounting bolt.
  4. Insert EVO Bracket into factory trackbar mount.
  5. Loosely Reinstall stock sway bar bolt into original location including through EVO's newly install bracket.





6. Mark forward and top holes to be drilled.







7. Move bolt and EVO Bracket to expose stock trackbar bracket.  
Drill both holes. Forward hole M8, Top Hole M6 Bolts.





8. If installing with extended adjustable trackbar, follow this step. If using stock length trackbar location, proceed to new step.

At New Extended Trackbar Location, small clearance will need to be made for trackbar bushing at new location and at bolt nut on coil mount. See red circles in image below. Small clearancing will be needed. Verify with your trackbar, clear as needed.





9. Paint all exposed metal areas, drills and clearances. Reinstall EVO Bracket and install new supplied hardware. Larger M8 bolt in the forward location. Smaller M6 bolt in the upper drilled location.

M6 Torque 15 N/M. M8 Torque 35 N/M





10. If using extended trackbar location. Put stock trackbar nut in vice as shown. Tap with hammer to give bend. This bend should be slight. Enough to give clearance with trackbar head.





11. Reinstall Sway bar link with factory bolt and modified stock nut tab.
12. Install trackbar at new higher location, either stock location or extended with supplied 9/16" Bolt, washers, nut. 9/16" Torque 129 Ft/Lb





After Install:

- After completing installation using provided instructions, go through all steps again to make sure nothing was missed, not tightened or improperly assembled.
- Some components may need to be purchased separately.
- Make sure all gauges are fully operational.
- Drive the vehicle slowly for a couple minutes, looking and listening for abnormal noises while driving. After modification of a vehicle there will be differences in driving experiences and capabilities, be mindful of that.
- Inspect and Retorque all Bolts after 500 miles of completed installation and regularly thereafter.

**General Recommended Torque Specs:**

Size	Grade 2		Grade 5		Grade 8		18-8 S/S	
	Coarse	Fine	Coarse	Fine	Coarse	Fine	Coarse	Fine
<b>#4*</b>	-	-	-	-	-	-	5.2	-
<b>#6*</b>	-	-	-	-	-	-	9.6	-
<b>#8*</b>	-	-	-	-	-	-	19.8	-
<b>#10*</b>	-	-	-	-	-	-	22.8	31.7
<b>1/4</b>	4	4.7	6.3	7.3	9	10	6.3	7.8
<b>5/16</b>	8	9	13	14	18	20	11	11.8
<b>3/8</b>	15	17	23	26	33	37	20	22
<b>7/16</b>	24	27	37	41	52	58	31	33
<b>1/2</b>	37	41	57	64	80	90	43	45
<b>9/16</b>	53	59	82	91	115	129	57	63
<b>5/8</b>	73	83	112	128	159	180	93	104
<b>3/4</b>	125	138	200	223	282	315	128	124
<b>7/8</b>	129	144	322	355	454	501	194	193



## Jeep JK Bumpstop front Installation Instructions



**IMPORTANT:** Read all instructions thoroughly from start to finish before beginning the install. Make sure all parts are included in the kit. If the instructions are not properly followed, severe frame, driveline and or suspension damage may result. Check for frame and suspension damage prior to installation. This kit does not require welding. Do not weld on any component. Welding may void the warranty and cause the product to fail. If any parts are missing, or for tech assistance; Contact King Off Road Racing Shocks. 714-530-8701 Most important after the install, Feel the difference, Nothing rides like a King.



Jeep JK Bumpstop front  
Installation Instructions

The vehicle will need to be safely supported on jackstands high enough to allow the front suspension to fully droop with the swaybar and driveshaft disconnected. \*Never work under an unsupported truck.

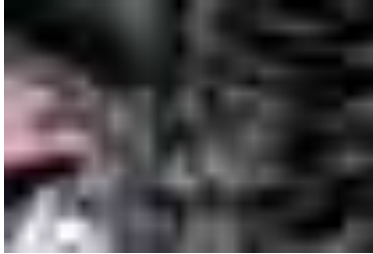

1. Remove the bolt holding the brake lines as shown.

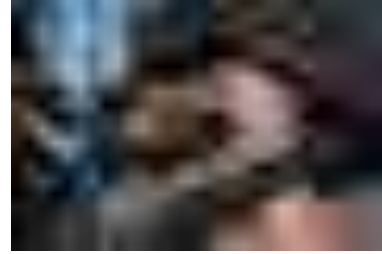

5. Pull the driveshaft back and let it hang down. You need to do this so the front end can droop fully.



2. Gently pry the bracket out on the end closest to the bolt.

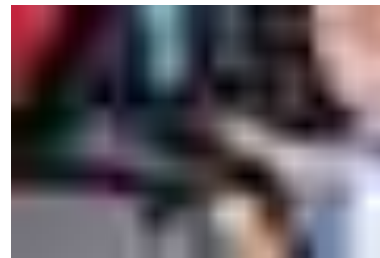

6. Push down on the axle and remove the springs starting on the passenger side.



3. Remove the swaybar links from both sides and unbolt the shocks.

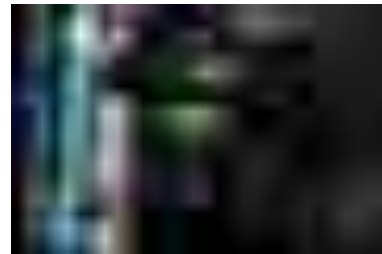

7. Wrap tape around the bumpstop mount as shown.

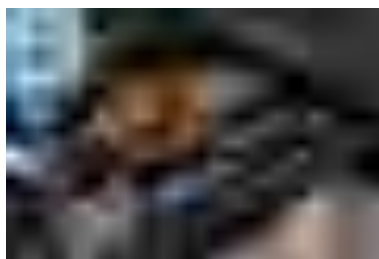

4. Brace the driveshaft so it does not rotate and remove the 4 bolts holding it to the flange.

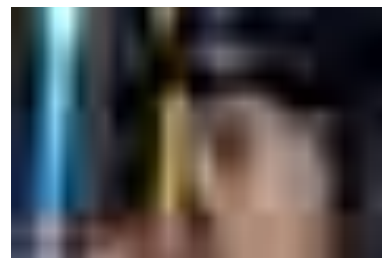

8. Mark 3" up from the bottom of the mount. A good practice is to use the tape measure graduations not the end of the tape that can move.





## Jeep JK Bumpstop front Installation Instructions



9. Before cutting remove the shock. You can use a sawzall or cutting wheel to make the cut. Make sure you wear a face shield and cut as straight and level as possible.



12. Once the cutting and trimming is complete you can mount the bumpstop. The bumpstop position locates on the upper ring. With the bumpstop in the mount, turn the upper collar on the threads until one thread is showing above the collar. This properly positions the bumpstop in the mount. Tighten the lower collar by hand.



10. Use a file to clean any rough edges or burrs from the mount.

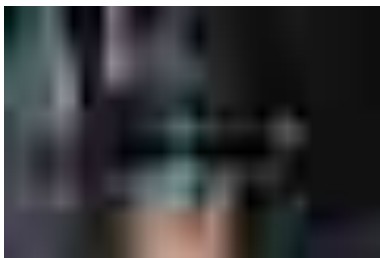

11. Time to do a trial fit. Push the bumpstop up into the mount and thread the top collar on. The bumpstop locates on the top of the mount. Making sure that the top collar is flush with the top of the mount inspect the bottom edge for any high or low spots that need to be trimmed. Mark those areas and carefully trim them until the lower bumpstop collar sits flush with your cut edge.

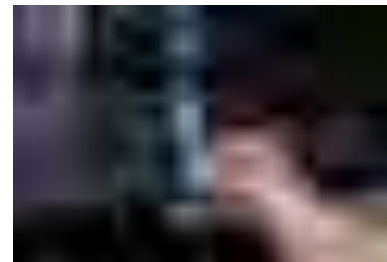
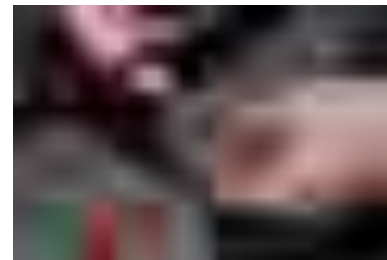
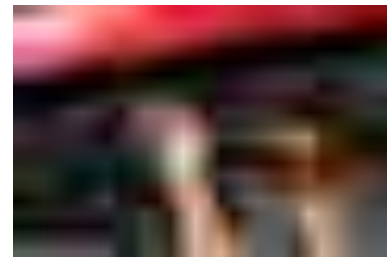
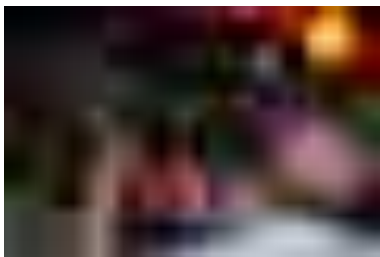

13. Using a punch gently tap the lower collar until it is tight. Apply locking compound on the supplied set-screws and tighten them into the threaded holes on the top and bottom collars.



## Jeep JK Bumpstop front Installation Instructions

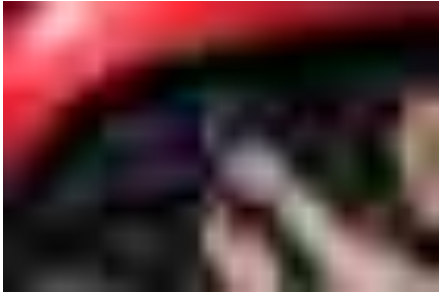

14. Now you can put the suspension back together. First slide the rubber coil spring isolator over the end of the bumpstop.

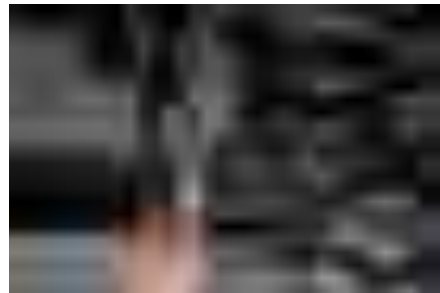

17. Slide the tab on the end of the cable mount into the slot in the far side of the coil mount and push the mount into the pocket.



15. Push the coil spring up into the top mount making sure that the coil is indexed to the lower mount as shown.

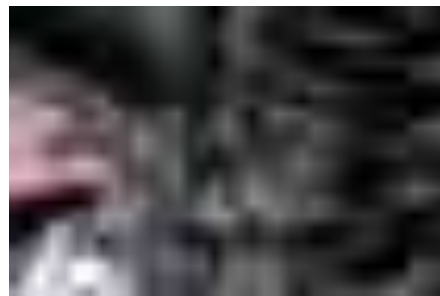

18. Replace the bolt through mount and thread into the captured nut and tighten.



16. While pushing down on the front axle move the bottom of the spring onto the lower mount. Make sure the end of the bottom coil sits in the relief on the lower mount.

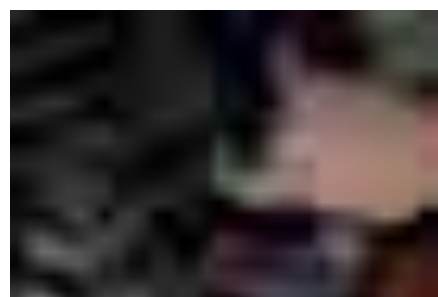

19. After performing the same steps on the opposite side, bolt up the swaybar ends and the driveshaft.



## Jeep JK Bumpstop front Installation Instructions

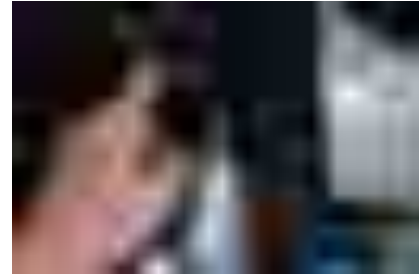
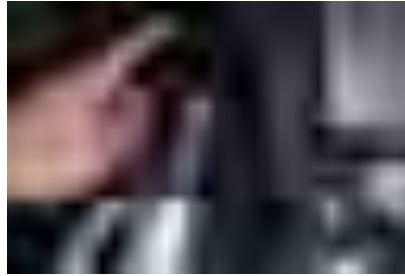

20. The lower rubber bushing and sleeve should be on the mounting pin as shown. Place the top rubber bushing, blue anodized plate and flat washer over the whole in the top mount and push the shock up into the mount. Thread the nut on the protruding pin.

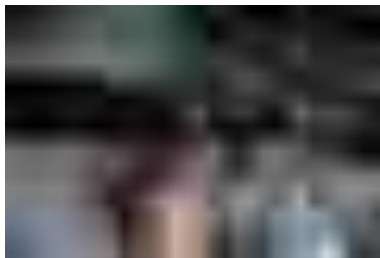

21. Insert the shaft end into the lower mount and replace the bolt, washer and nut and tighten. Tighten the top nut until the bushings begin to compress,  
**\*Do not overtighten**



**Repeat the same steps on the opposite side. Go back and make sure when you are done that all the nuts, bolts, lug nuts and clamps are tight and nothing is rubbing before driving the vehicle. After 50 miles or so; check to make sure everything is still tight. If you have any questions call 714-530-8701 for further assistance.**



EVO Manufacturing  
Jeep Wrangler JL/JT Gladiator  
JL/JT Brake Line  
EVO- 600132/600170





Before starting installation procedure please read <http://evomfg.com>Returns-Warranties-Shipping>

**CAREFULLY READ AND FOLLOW ALL INSTRUCTIONS IN THIS MANUAL AND KEEP FOR FUTURE REFERENCE. IF YOU HAVE ANY QUESTIONS ABOUT THE PRODUCT CALL EVO MANUFACTURING. FAILURE TO FOLLOW GUIDELINES COULD RESULT IN MALFUNCTION OF PARTS OR INJURY. PLEASE HAVE A TRAINED PROFESSIONAL ASSIST WITH OR INSTALL ALL PRODUCTS. INSTALLING EVO MFG PRODUCTS OR KITS DEMANDS SPECIFIC KNOWLEDGE, TOOLS AND EXPERIENCE. GENERAL KNOWLEDGE OF HOW TO USE LATER SPECIFIED TOOLS AND/OR LIMITED EXPERIENCE WITH EVO MFG PRODUCTS MAY NOT BE ENOUGH TO PROPERLY COMPLETE THESE TASKS. SOME OF EVO MFG PRODUCTS MAY REQUIRE TWO OR MORE PEOPLE TO INSTALL SAFELY AND CORRECTLY. DO NOT ATTEMPT ALONE, ALWAYS ENLIST THE HELP OF TRAINED PROFESSIONAL WHEN NEEDED.**

**Notes: Set Up Before installation**

**Do not crimp/pinch line. Always check for leaking fluids and that brakes work correctly. Bleeding brakes is extremely important to be done properly. Follow factory specifications in doing so.**

**This is a general instruction for this component kit.**

**Directions/pictures may vary for each specific install, use for reference only.**

**Keep all mounting bolts loose (installed but not torqued) we will torque later at the end of complete installation**

**READ BEFORE INSTALL:**

It is generally a good idea to apply Loctite to all threaded bolts.

ALWAYS wear safety glasses and other approved safety gear when working on a vehicle.

All supplied bolts torqued according to chart at end of instruction.

It is recommended all installation be performed by a trained professional. Some modification may have to be done.

Paint all unfinished surfaces after install is complete.



Parts included: Table below shows JL/JT Rear Brake Line.

Description	#	Part #	Quantity
JL/JT Brake Lines	1	EVO-600132	2





**Recommended Tools:**

- Wrench Set (standard/metric)



**Safety Steps for installation**

- For installing EVO MFG products always use wheel chokes to block rear tires from rolling.
- Always make sure you have everything necessary ready before install.
- If you have to, carefully lift front of vehicle by front frame rails extending suspension until tires leave the ground, place frame on approved jack stands for vehicle. Verify all lines/wires are not over extended.
- Remove tires if needed for easier install.
- Make sure to wear safety equipment (eye protection, hand protection, foot protection etc.) at all times during installation.
- Make sure all safety precautions have been taken.
- Always check and replace any part of vehicle that is worn or broken before starting install.
- Do not mix anything EVO with weaker alternatives.
- It is generally a good idea to apply liquid threadlock to all bolts.
- Tighten included hardware to torque specifications in bottom table unless it is otherwise specified, factory bolts should be torqued to factory Jeep specifications.





**INSTALL:** After putting vehicle in park, chocked the wheels and remove the key.

1. Using a 15mm socket remove the banjo bolt from caliper, Remove the banjo bolt from the brake hose, remove the copper washers.
  2. Remove bolt and bracket holding the brake line on the axle tube using a 10mm wrench, located under spring bracket.
  3. Moving swiftly/carefully separate the hard line from the bracket/hose on frame by holding hardline with a 12mm wrench and unscrewing the rubber hose with a 16mm wrench.
- 



4. Install new copper crush washers on to the factory banjo bolt, Insert the factory banjo bolt with copper crush washer on through the banjo of the new stainless steel brake line, then slip another copper crush washer on.
- 







5. Using a 15mm socket, secure your new stainless steel break line to the break caliper using factory hardware, tighten the banjo bolt to 276 in. lbs. of torque **(at caliper hard line elbow extends towards front of vehicle and angled up as much as possible.)**
- 



6. The mid line retaining bracket on new steel braided brake line needs to be installed using factory 10mm bolt at previous axle mounting location.
- 



7. Use a 12mm wrench to hold hardline and a 19mm wrench to secure your new stainless steel brake line to mounting bracket on the frame.
  8. Repeat previous brake line procedures on opposite front brake line.
  9. Check the fluid level in your master cylinder. Bleed front brakes following factory procedures.
- 

**Note:** Carefully move line. Do not crimp/pinch line. Always check for leaking fluids and that brakes work correctly. Bleeding brakes is extremely important to be done properly. Follow factory specifications in doing so. Consultation/should be performed by a trained professional mechanic.



After Install:

- Tighten all bolts securing purchased parts to specified locations.
- After completing installation using provided instructions, go through all steps again to make sure nothing was missed, not tightened or improperly assembled.
- Some components may need to be purchased separately.
- Check turn signals, headlights, fog lights (if applicable), taillights, blinkers and windshield wipers.
- Adjust mirrors, speedometer and headlights if needed.
- Make sure all gauges are fully operational.
- Drive the vehicle slowly for a couple minutes, looking and listening for abnormal noises while driving. After modification of a vehicle there will be differences in driving experiences and capabilities, be mindful of that.
- Inspect and Retorque all Bolts after 500 miles of completed installation and regularly thereafter.
- Some modification may be required.

Recommended Torque:

Size	Grade 2		Grade 5		Grade 8		18-8 S/S	
	Coarse	Fine	Coarse	Fine	Coarse	Fine	Coarse	Fine
<b>#4*</b>	-	-	-	-	-	-	5.2	-
<b>#6*</b>	-	-	-	-	-	-	9.6	-
<b>#8*</b>	-	-	-	-	-	-	19.8	-
<b>#10*</b>	-	-	-	-	-	-	22.8	31.7
<b>1/4</b>	4	4.7	6.3	7.3	9	10	6.3	7.8
<b>5/16</b>	8	9	13	14	18	20	11	11.8
<b>3/8</b>	15	17	23	26	33	37	20	22
<b>7/16</b>	24	27	37	41	52	58	31	33
<b>1/2</b>	37	41	57	64	80	90	43	45
<b>9/16</b>	53	59	82	91	115	129	57	63
<b>5/8</b>	73	83	112	128	159	180	93	104
<b>3/4</b>	125	138	200	223	282	315	128	124
<b>7/8</b>	129	144	322	355	454	501	194	193
<b>1†</b>	188	210	483	541	682	764	287	289



**2021+ Ford Bronco 2.5 Front Coilover**

King Shocks 12472 Edison Way Garden Grove, CA 92841  
714-530-8701 [www.kingshocks.com](http://www.kingshocks.com)

**Front Parts List:**

- 2 – 2.5 Front Coilover Shocks (25001-392)
- 2 – Reservoir Brackets (25048-063)
- 1 – Hardware Kit (KH02-181)

**Tools Required:**

- Floor Jack/Jack Stands
- Metric Wrench/Socket Set
- Standard Wrench/Socket Set

**2021 Ford Bronco**  
*DEM PERFORMANCE SERIES*

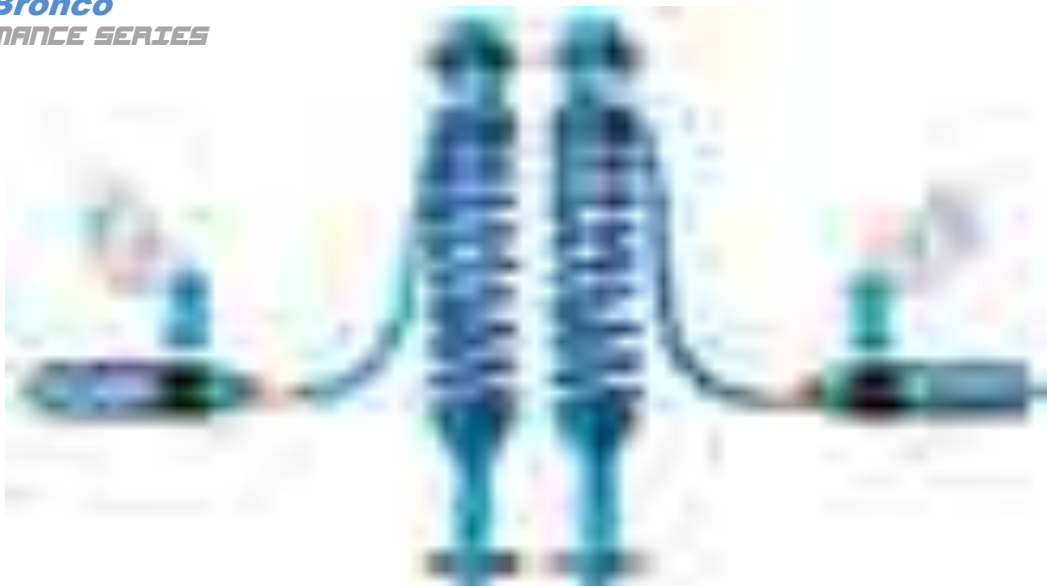

**FRONT:** With the vehicle on level ground, set the emergency brake and block the rear tires. Using a floor jack, raise the front end and support the frame rails with jack stands for safety. Remove front tires. **NOTE: Never work under an unsupported vehicle.**

1. Unbolt the ABS and brake line bracket from the knuckle. Be careful not to damage the brake and ABS lines as you are removing and installing shocks.



**IMPORTANT:** Read all instructions thoroughly from start to finish before beginning the install. Check parts list and make sure all parts are included in the kit. If the instructions are not properly followed severe frame, driveline and/or suspension damage may result. Check for frame and suspension damage prior to installation.

This kit does not require welding. Do not weld on any component. Welding may void the warranty and/or cause the product to fail. If any parts are missing, or for tech assistance; Contact King Off Road Racing Shocks: 714-530-8701 Most important after the install, Feel the difference and have fun.



## 2021+ Ford Bronco 2.5 Front Coilover

King Shocks 12472 Edison Way Garden Grove, CA 92841  
714-530-8701 [www.kingshocks.com](http://www.kingshocks.com)

2. Remove the lower mounting nuts using an 18mm wrench or socket.



3. Remove the upper mounting nuts using a 15mm wrench or socket.



4. Separate the upper control arm from the knuckle. Using an 18mm wrench or socket remove the nut for the control arm ball joint, then disconnect upper arm from knuckle.



**IMPORTANT:** Read all instructions thoroughly from start to finish before beginning the install. Check parts list and make sure all parts are included in the kit. If the instructions are not properly followed severe frame, driveline and/or suspension damage may result. Check for frame and suspension damage prior to installation.

This kit does not require welding. Do not weld on any component. Welding may void the warranty and/or cause the product to fail. If any parts are missing, or for tech assistance; Contact King Off Road Racing Shocks: 714-530-8701 Most important after the install, Feel the difference and have fun.



2021+ Ford Bronco 2.5 Front Coilover

King Shocks 12472 Edison Way Garden Grove, CA 92841  
714-530-8701 [www.kingshocks.com](http://www.kingshocks.com)

5. Remove the nut from the tie rod end using a 21mm socket and separate the tie rod from the knuckle.



6. Disconnect the sway bar links on both sides of the vehicle. Remove the nut using a 21mm wrench, you may need to hold the stud with a hex key to keep the stud from spinning.



**IMPORTANT:** Read all instructions thoroughly from start to finish before beginning the install. Check parts list and make sure all parts are included in the kit. If the instructions are not properly followed severe frame, driveline and/or suspension damage may result. Check for frame and suspension damage prior to installation.

This kit does not require welding. Do not weld on any component. Welding may void the warranty and/or cause the product to fail. If any parts are missing, or for tech assistance; Contact King Off Road Racing Shocks: 714-530-8701 Most important after the install, Feel the difference and have fun.



## 2021+ Ford Bronco 2.5 Front Coilover

King Shocks 12472 Edison Way Garden Grove, CA 92841  
714-530-8701 [www.kingshocks.com](http://www.kingshocks.com)

7. **Remove shocks from vehicle** – For standard base model shocks you should be able to push down on the lower control arm while pulling the studs from the bottom of the shock out of the lower control arm. Then remove shock from vehicle. The longer Bilstein shocks can be tricky to remove on the left side. In order to remove the shock on the left side you may need to remove the lower control arm bolts. Make match marks on the cams so you can put the control arms back in the stock locations. Remove front lower control arm bolt and slide the rear bolt out as far as you can. This will allow you to push the lower control arm down enough to get the studs out of the lower control arm. Pull the bottom of the shock out of the lower control arm, then remove shock from vehicle.

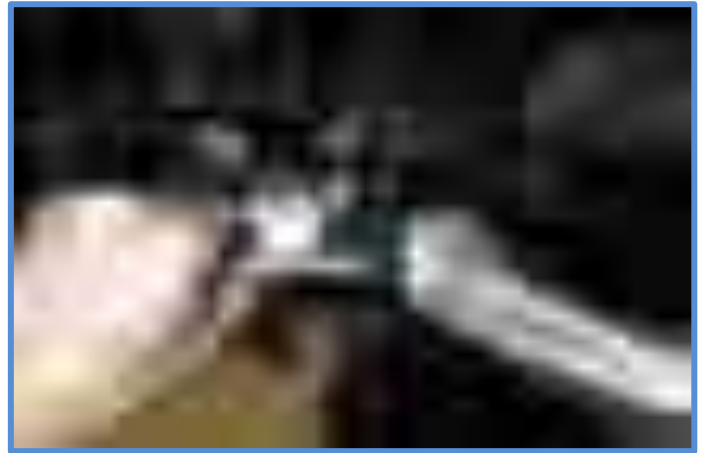

Place the lower control arm back into the lower mount and install the cam bolts to the same position prior to removal. The vehicle will need to be aligned properly after the install but keeping the factory settings will get you to the alignment shop. Tighten lower control arm bolts to factory specs after the vehicle is sitting back on the ground. Removing right shock should not require removing lower control arm bolts. Remove right shock and move to next step...

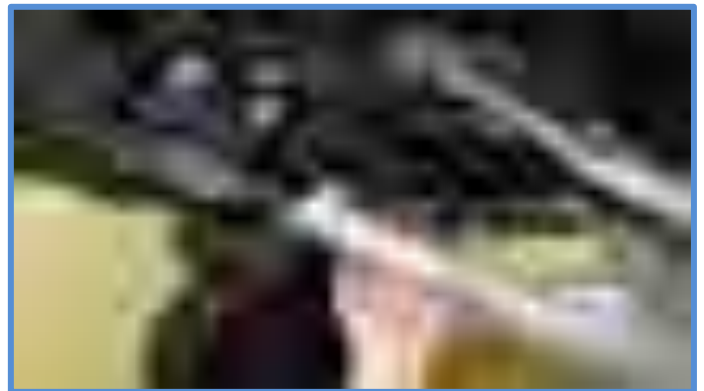

**IMPORTANT:** Read all instructions thoroughly from start to finish before beginning the install. Check parts list and make sure all parts are included in the kit. If the instructions are not properly followed severe frame, driveline and/or suspension damage may result. Check for frame and suspension damage prior to installation.

This kit does not require welding. Do not weld on any component. Welding may void the warranty and/or cause the product to fail. If any parts are missing, or for tech assistance; Contact King Off Road Racing Shocks: 714-530-8701 Most important after the install, Feel the difference and have fun.



**2021+ Ford Bronco 2.5 Front Coilover**

King Shocks 12472 Edison Way Garden Grove, CA 92841  
714-530-8701 [www.kingshocks.com](http://www.kingshocks.com)

8. **Installing King Shocks** - Shocks are side specific, make sure you are installing shocks on the correct side - *(hose and reservoir will be towards the front of the vehicle)*. Maneuver the top of the shock into the upper mount then place the shock on the lower control arm.



9. Place the supplied 3/8 HD Washers (CW1701) on the mounting studs followed by the 3/8 nuts (CN2711). Thread the nuts on to hold shock in place and proceed to next step.



**IMPORTANT:** Read all instructions thoroughly from start to finish before beginning the install. Check parts list and make sure all parts are included in the kit. If the instructions are not properly followed severe frame, driveline and/or suspension damage may result. Check for frame and suspension damage prior to installation.

This kit does not require welding. Do not weld on any component. Welding may void the warranty and/or cause the product to fail. If any parts are missing, or for tech assistance; Contact King Off Road Racing Shocks: 714-530-8701 Most important after the install, Feel the difference and have fun.



2021+ Ford Bronco 2.5 Front Coilover

King Shocks 12472 Edison Way Garden Grove, CA 92841  
714-530-8701 [www.kingshocks.com](http://www.kingshocks.com)

10. Install the provided 12mm X 80mm bolt (CB3829) with washer (CW1001) and reducer sleeve up through the lower control arm and lower mounting lug. Install the provided nut with washer on the top side.

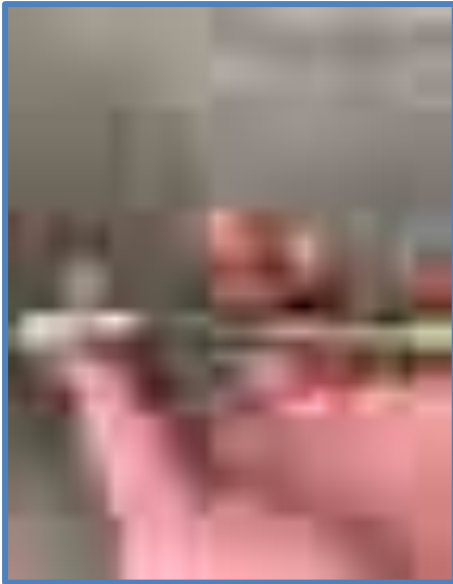

11. Reconnect tie rod and tighten to factory specs.



12. Reconnect the upper control arm and tighten to factory specs.



**IMPORTANT:** Read all instructions thoroughly from start to finish before beginning the install. Check parts list and make sure all parts are included in the kit. If the instructions are not properly followed severe frame, driveline and/or suspension damage may result. Check for frame and suspension damage prior to installation.

This kit does not require welding. Do not weld on any component. Welding may void the warranty and/or cause the product to fail. If any parts are missing, or for tech assistance; Contact King Off Road Racing Shocks: 714-530-8701 Most important after the install, Feel the difference and have fun.





**2021+ Ford Bronco 2.5 Front Coilover**

King Shocks 12472 Edison Way Garden Grove, CA 92841  
714-530-8701 [www.kingshocks.com](http://www.kingshocks.com)

13. Now you can torque the upper and lower mounting hardware. Torque the upper nuts to 35 ft/lbs. using a 9/16 socket. Torque lower bolts to 90 ft/lbs. using a 19mm wrench/socket.



14. Reinstall ABS/brake line bracket.



15. Reconnect the sway bar links.



**IMPORTANT:** Read all instructions thoroughly from start to finish before beginning the install. Check parts list and make sure all parts are included in the kit. If the instructions are not properly followed severe frame, driveline and/or suspension damage may result. Check for frame and suspension damage prior to installation.

This kit does not require welding. Do not weld on any component. Welding may void the warranty and/or cause the product to fail. If any parts are missing, or for tech assistance; Contact King Off Road Racing Shocks: 714-530-8701 Most important after the install, Feel the difference and have fun.



## 2021+ Ford Bronco 2.5 Front Coilover

King Shocks 12472 Edison Way Garden Grove, CA 92841  
714-530-8701 [www.kingshocks.com](http://www.kingshocks.com)

16. **Mounting reservoirs** - First attach the reservoir clamps to the reservoir brackets as shown below. Install the 1/4 X 1/2" BHCS (CB2420) with red locktite and tighten using a 5/32 Hex Key.

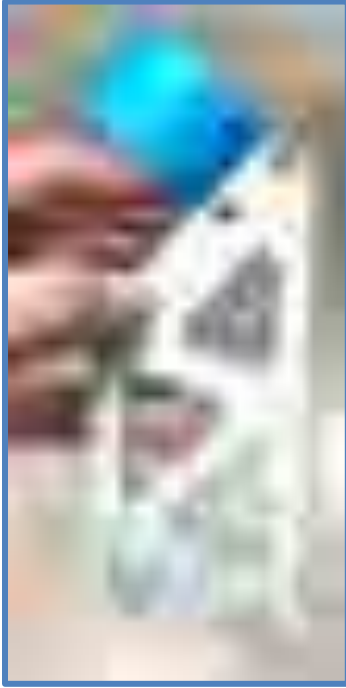

17. Remove the two factory bolts and the factory cross member extensions (if applicable) from the front cross member as shown below.



**IMPORTANT:** Read all instructions thoroughly from start to finish before beginning the install. Check parts list and make sure all parts are included in the kit. If the instructions are not properly followed severe frame, driveline and/or suspension damage may result. Check for frame and suspension damage prior to installation.

This kit does not require welding. Do not weld on any component. Welding may void the warranty and/or cause the product to fail. If any parts are missing, or for tech assistance; Contact King Off Road Racing Shocks: 714-530-8701 Most important after the install, Feel the difference and have fun.



## 2021+ Ford Bronco 2.5 Front Coilover

King Shocks 12472 Edison Way Garden Grove, CA 92841  
714-530-8701 [www.kingshocks.com](http://www.kingshocks.com)

18. Slide the reservoir into the reservoir clamp then place the bracket on the nuts on the front cross member. Install the provided M12 X 30mm bolts (CB3833) with washers (CW1001). Push the bracket forward and in towards frame as much as possible and tighten bolts.

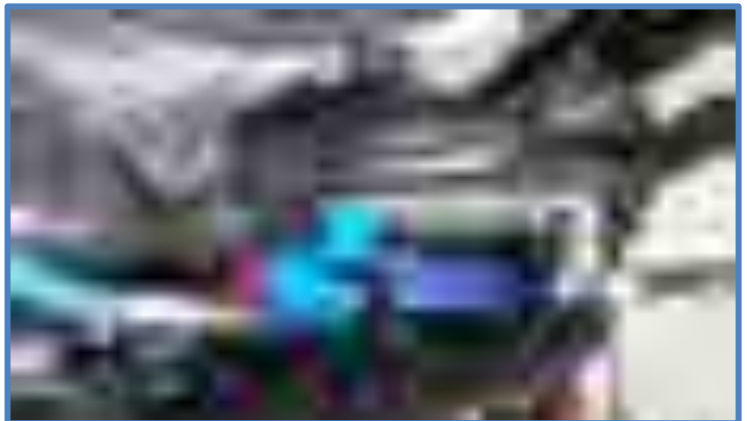

19. Install the 1/4 X 1" bolts (CB1501) in the reservoir clamp and tighten using a 3/16 Hex Key.



**IMPORTANT:** Read all instructions thoroughly from start to finish before beginning the install. Check parts list and make sure all parts are included in the kit. If the instructions are not properly followed severe frame, driveline and/or suspension damage may result. Check for frame and suspension damage prior to installation.

This kit does not require welding. Do not weld on any component. Welding may void the warranty and/or cause the product to fail. If any parts are missing, or for tech assistance; Contact King Off Road Racing Shocks: 714-530-8701 Most important after the install, Feel the difference and have fun.



**2021+ Ford Bronco 2.5 Front Coilover**

King Shocks 12472 Edison Way Garden Grove, CA 92841  
714-530-8701 [www.kingshocks.com](http://www.kingshocks.com)



**DOUBLE CHECK ALL HARDWARE:**

Make sure everything is installed correctly and all hardware is tight before reinstalling tires. Install tires, remove jack stands and lower vehicle to the ground. Recheck all hardware and lug nuts after 100 miles and periodically after that as part of routine maintenance.

**Alignment is critical:**

A professional alignment must be performed before driving this vehicle at highway speeds. Do not attempt to drive your vehicle after this install without having the alignment readjusted to factory specs!

**IMPORTANT:** Read all instructions thoroughly from start to finish before beginning the install. Check parts list and make sure all parts are included in the kit. If the instructions are not properly followed severe frame, driveline and/or suspension damage may result. Check for frame and suspension damage prior to installation.

This kit does not require welding. Do not weld on any component. Welding may void the warranty and/or cause the product to fail. If any parts are missing, or for tech assistance; Contact King Off Road Racing Shocks: 714-530-8701 Most important after the install, Feel the difference and have fun.



**2021+ Ford Bronco 2.5 Front Coilover**

King Shocks 12472 Edison Way Garden Grove, CA 92841  
714-530-8701 [www.kingshocks.com](http://www.kingshocks.com)

**Front Parts List:**

- 2 – 2.5 Front Coilover Shocks (25001-392)
- 2 – Reservoir Brackets (25048-063)
- 1 – Hardware Kit (KH02-181)

**Tools Required:**

- Floor Jack/Jack Stands
- Metric Wrench/Socket Set
- Standard Wrench/Socket Set

**2021 Ford Bronco**  
*DEM PERFORMANCE SERIES*

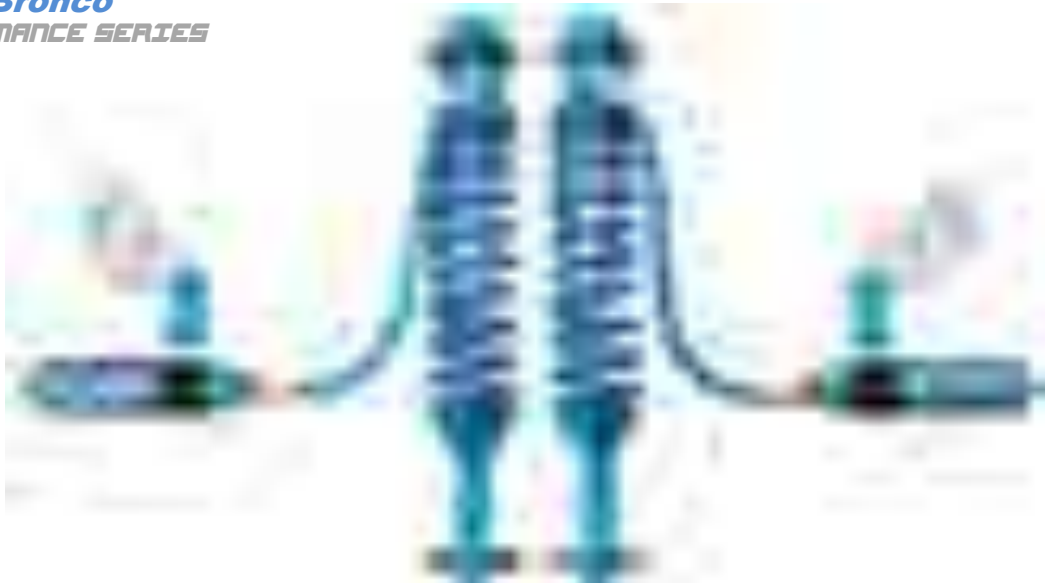

**FRONT:** With the vehicle on level ground, set the emergency brake and block the rear tires. Using a floor jack, raise the front end and support the frame rails with jack stands for safety. Remove front tires. **NOTE: Never work under an unsupported vehicle.**

1. Unbolt the ABS and brake line bracket from the knuckle. Be careful not to damage the brake and ABS lines as you are removing and installing shocks.



**IMPORTANT:** Read all instructions thoroughly from start to finish before beginning the install. Check parts list and make sure all parts are included in the kit. If the instructions are not properly followed severe frame, driveline and/or suspension damage may result. Check for frame and suspension damage prior to installation.

This kit does not require welding. Do not weld on any component. Welding may void the warranty and/or cause the product to fail. If any parts are missing, or for tech assistance; Contact King Off Road Racing Shocks: 714-530-8701 Most important after the install, Feel the difference and have fun.



**2021+ Ford Bronco 2.5 Front Coilover**

King Shocks 12472 Edison Way Garden Grove, CA 92841  
714-530-8701 [www.kingshocks.com](http://www.kingshocks.com)

2. Remove the lower mounting nuts using an 18mm wrench or socket.



3. Remove the upper mounting nuts using a 15mm wrench or socket.



4. Separate the upper control arm from the knuckle. Using an 18mm wrench or socket remove the nut for the control arm ball joint, then disconnect upper arm from knuckle.



**IMPORTANT:** Read all instructions thoroughly from start to finish before beginning the install. Check parts list and make sure all parts are included in the kit. If the instructions are not properly followed severe frame, driveline and/or suspension damage may result. Check for frame and suspension damage prior to installation.

This kit does not require welding. Do not weld on any component. Welding may void the warranty and/or cause the product to fail. If any parts are missing, or for tech assistance; Contact King Off Road Racing Shocks: 714-530-8701 Most important after the install, Feel the difference and have fun.



**2021+ Ford Bronco 2.5 Front Coilover**

King Shocks 12472 Edison Way Garden Grove, CA 92841  
714-530-8701 [www.kingshocks.com](http://www.kingshocks.com)

5. Remove the nut from the tie rod end using a 21mm socket and separate the tie rod from the knuckle.



6. Disconnect the sway bar links on both sides of the vehicle. Remove the nut using a 21mm wrench, you may need to hold the stud with a hex key to keep the stud from spinning.



**IMPORTANT:** Read all instructions thoroughly from start to finish before beginning the install. Check parts list and make sure all parts are included in the kit. If the instructions are not properly followed severe frame, driveline and/or suspension damage may result. Check for frame and suspension damage prior to installation.

This kit does not require welding. Do not weld on any component. Welding may void the warranty and/or cause the product to fail. If any parts are missing, or for tech assistance; Contact King Off Road Racing Shocks: 714-530-8701 Most important after the install, Feel the difference and have fun.



## 2021+ Ford Bronco 2.5 Front Coilover

King Shocks 12472 Edison Way Garden Grove, CA 92841  
714-530-8701 [www.kingshocks.com](http://www.kingshocks.com)

7. **Remove shocks from vehicle** – For standard base model shocks you should be able to push down on the lower control arm while pulling the studs from the bottom of the shock out of the lower control arm. Then remove shock from vehicle. The longer Bilstein shocks can be tricky to remove on the left side. In order to remove the shock on the left side you may need to remove the lower control arm bolts. Make match marks on the cams so you can put the control arms back in the stock locations. Remove front lower control arm bolt and slide the rear bolt out as far as you can. This will allow you to push the lower control arm down enough to get the studs out of the lower control arm. Pull the bottom of the shock out of the lower control arm, then remove shock from vehicle.



Place the lower control arm back into the lower mount and install the cam bolts to the same position prior to removal. The vehicle will need to be aligned properly after the install but keeping the factory settings will get you to the alignment shop. Tighten lower control arm bolts to factory specs after the vehicle is sitting back on the ground. Removing right shock should not require removing lower control arm bolts. Remove right shock and move to next step...

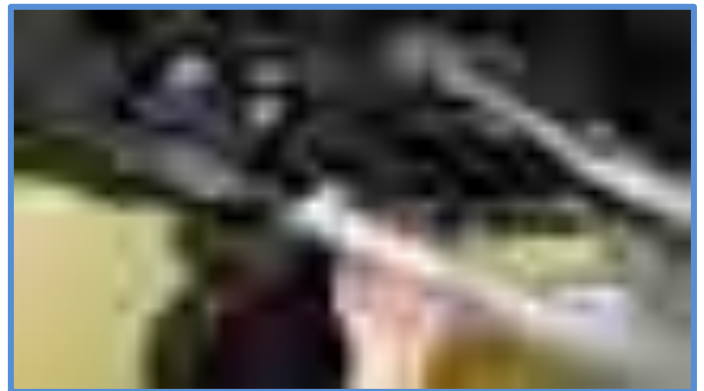

**IMPORTANT:** Read all instructions thoroughly from start to finish before beginning the install. Check parts list and make sure all parts are included in the kit. If the instructions are not properly followed severe frame, driveline and/or suspension damage may result. Check for frame and suspension damage prior to installation.

This kit does not require welding. Do not weld on any component. Welding may void the warranty and/or cause the product to fail. If any parts are missing, or for tech assistance; Contact King Off Road Racing Shocks: 714-530-8701 Most important after the install, Feel the difference and have fun.





**2021+ Ford Bronco 2.5 Front Coilover**

King Shocks 12472 Edison Way Garden Grove, CA 92841  
714-530-8701 [www.kingshocks.com](http://www.kingshocks.com)

8. **Installing King Shocks** - Shocks are side specific, make sure you are installing shocks on the correct side - *(hose and reservoir will be towards the front of the vehicle)*. Maneuver the top of the shock into the upper mount then place the shock on the lower control arm.



9. Place the supplied 3/8 HD Washers (CW1701) on the mounting studs followed by the 3/8 nuts (CN2711). Thread the nuts on to hold shock in place and proceed to next step.



**IMPORTANT:** Read all instructions thoroughly from start to finish before beginning the install. Check parts list and make sure all parts are included in the kit. If the instructions are not properly followed severe frame, driveline and/or suspension damage may result. Check for frame and suspension damage prior to installation.

This kit does not require welding. Do not weld on any component. Welding may void the warranty and/or cause the product to fail. If any parts are missing, or for tech assistance; Contact King Off Road Racing Shocks: 714-530-8701 Most important after the install, Feel the difference and have fun.



**2021+ Ford Bronco 2.5 Front Coilover**

King Shocks 12472 Edison Way Garden Grove, CA 92841  
714-530-8701 [www.kingshocks.com](http://www.kingshocks.com)

10. Install the provided 12mm X 80mm bolt (CB3829) with washer (CW1001) and reducer sleeve up through the lower control arm and lower mounting lug. Install the provided nut with washer on the top side.

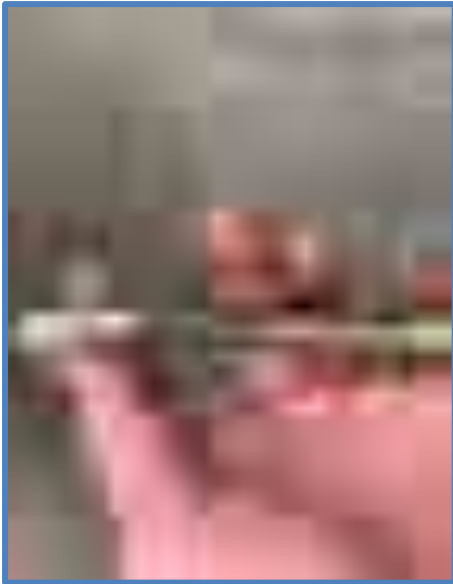

11. Reconnect tie rod and tighten to factory specs.



12. Reconnect the upper control arm and tighten to factory specs.



**IMPORTANT:** Read all instructions thoroughly from start to finish before beginning the install. Check parts list and make sure all parts are included in the kit. If the instructions are not properly followed severe frame, driveline and/or suspension damage may result. Check for frame and suspension damage prior to installation.

This kit does not require welding. Do not weld on any component. Welding may void the warranty and/or cause the product to fail. If any parts are missing, or for tech assistance; Contact King Off Road Racing Shocks: 714-530-8701 Most important after the install, Feel the difference and have fun.



**2021+ Ford Bronco 2.5 Front Coilover**

King Shocks 12472 Edison Way Garden Grove, CA 92841  
714-530-8701 [www.kingshocks.com](http://www.kingshocks.com)

13. Now you can torque the upper and lower mounting hardware. Torque the upper nuts to 35 ft/lbs. using a 9/16 socket. Torque lower bolts to 90 ft/lbs. using a 19mm wrench/socket.



14. Reinstall ABS/brake line bracket.



15. Reconnect the sway bar links.



**IMPORTANT:** Read all instructions thoroughly from start to finish before beginning the install. Check parts list and make sure all parts are included in the kit. If the instructions are not properly followed severe frame, driveline and/or suspension damage may result. Check for frame and suspension damage prior to installation.

This kit does not require welding. Do not weld on any component. Welding may void the warranty and/or cause the product to fail. If any parts are missing, or for tech assistance; Contact King Off Road Racing Shocks: 714-530-8701 Most important after the install, Feel the difference and have fun.



**2021+ Ford Bronco 2.5 Front Coilover**

King Shocks 12472 Edison Way Garden Grove, CA 92841  
714-530-8701 [www.kingshocks.com](http://www.kingshocks.com)

16. **Mounting reservoirs** - First attach the reservoir clamps to the reservoir brackets as shown below. Install the 1/4 X 1/2" BHCS (CB2420) with red locktite and tighten using a 5/32 Hex Key.

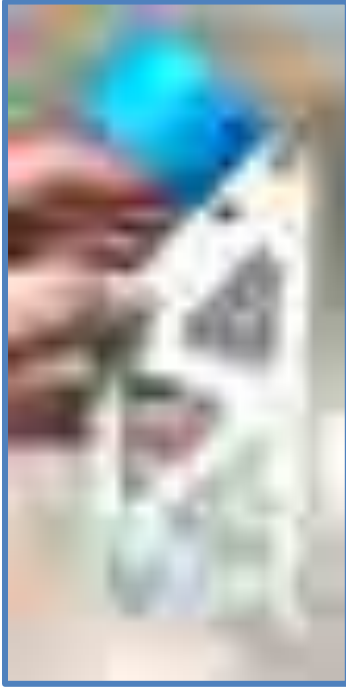

17. Remove the two factory bolts and the factory cross member extensions (if applicable) from the front cross member as shown below.



**IMPORTANT:** Read all instructions thoroughly from start to finish before beginning the install. Check parts list and make sure all parts are included in the kit. If the instructions are not properly followed severe frame, driveline and/or suspension damage may result. Check for frame and suspension damage prior to installation.

This kit does not require welding. Do not weld on any component. Welding may void the warranty and/or cause the product to fail. If any parts are missing, or for tech assistance; Contact King Off Road Racing Shocks: 714-530-8701 Most important after the install, Feel the difference and have fun.



## 2021+ Ford Bronco 2.5 Front Coilover

King Shocks 12472 Edison Way Garden Grove, CA 92841  
714-530-8701 [www.kingshocks.com](http://www.kingshocks.com)

18. Slide the reservoir into the reservoir clamp then place the bracket on the nuts on the front cross member. Install the provided M12 X 30mm bolts (CB3833) with washers (CW1001). Push the bracket forward and in towards frame as much as possible and tighten bolts.

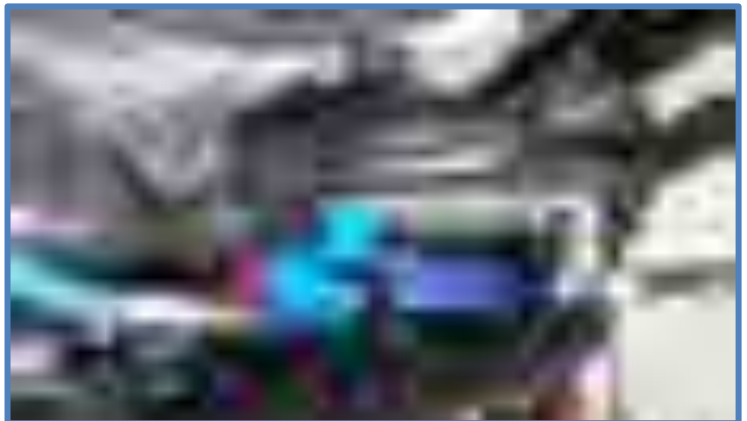

19. Install the 1/4 X 1" bolts (CB1501) in the reservoir clamp and tighten using a 3/16 Hex Key.



**IMPORTANT:** Read all instructions thoroughly from start to finish before beginning the install. Check parts list and make sure all parts are included in the kit. If the instructions are not properly followed severe frame, driveline and/or suspension damage may result. Check for frame and suspension damage prior to installation.

This kit does not require welding. Do not weld on any component. Welding may void the warranty and/or cause the product to fail. If any parts are missing, or for tech assistance; Contact King Off Road Racing Shocks: 714-530-8701 Most important after the install, Feel the difference and have fun.



**2021+ Ford Bronco 2.5 Front Coilover**

King Shocks 12472 Edison Way Garden Grove, CA 92841  
714-530-8701 [www.kingshocks.com](http://www.kingshocks.com)



**DOUBLE CHECK ALL HARDWARE:**

Make sure everything is installed correctly and all hardware is tight before reinstalling tires. Install tires, remove jack stands and lower vehicle to the ground. Recheck all hardware and lug nuts after 100 miles and periodically after that as part of routine maintenance.

**Alignment is critical:**

A professional alignment must be performed before driving this vehicle at highway speeds. Do not attempt to drive your vehicle after this install without having the alignment readjusted to factory specs!

**IMPORTANT:** Read all instructions thoroughly from start to finish before beginning the install. Check parts list and make sure all parts are included in the kit. If the instructions are not properly followed severe frame, driveline and/or suspension damage may result. Check for frame and suspension damage prior to installation.

This kit does not require welding. Do not weld on any component. Welding may void the warranty and/or cause the product to fail. If any parts are missing, or for tech assistance; Contact King Off Road Racing Shocks: 714-530-8701 Most important after the install, Feel the difference and have fun.



**2021+ Ford Bronco 2.5 Rear Coilover**

King Shocks 12472 Edison Way Garden Grove, CA 92841  
714-530-8701 [www.kingshocks.com](http://www.kingshocks.com)

**Rear Parts List:**

- 2 – 2.5 Rear Coilover Shocks (25001-393)
- 2 – Reservoir Brackets (25048-064/065)
- 1 – Hardware Kit (KH02-182)

**Tools Required:**

- Floor Jack/Jack Stands
- Metric Wrench/Socket Set
- Standard Wrench/Socket Set

**2021 Ford Bronco**  
*DEM PERFORMANCE SERIES*



**REAR:** With the vehicle on level ground, block the front tires. Using a floor jack, raise the rear end and support the frame rails with jack stands for safety. Remove rear tires. **NOTE: Never work under an unsupported vehicle.**

1. Remove the existing shocks by removing the lower mounting bolt and upper mount nuts. First remove the lower bolt using a 27mm socket. Support the axle with a jack or jack stands when removing the bolt.



**IMPORTANT:** Read all instructions thoroughly from start to finish before beginning the install. Check parts list and make sure all parts are included in the kit. If the instructions are not properly followed severe frame, driveline and/or suspension damage may result. Check for frame and suspension damage prior to installation.

This kit does not require welding. Do not weld on any component. Welding may void the warranty and/or cause the product to fail. If any parts are missing, or for tech assistance; Contact King Off Road Racing Shocks: 714-530-8701 Most important after the install, Feel the difference and have fun.



**2021+ Ford Bronco 2.5 Rear Coilover**

King Shocks 12472 Edison Way Garden Grove, CA 92841  
714-530-8701 [www.kingshocks.com](http://www.kingshocks.com)

2. Remove the nuts from the upper mount using a 15mm wrench/socket or ratchet wrench, then remove shocks from vehicle.

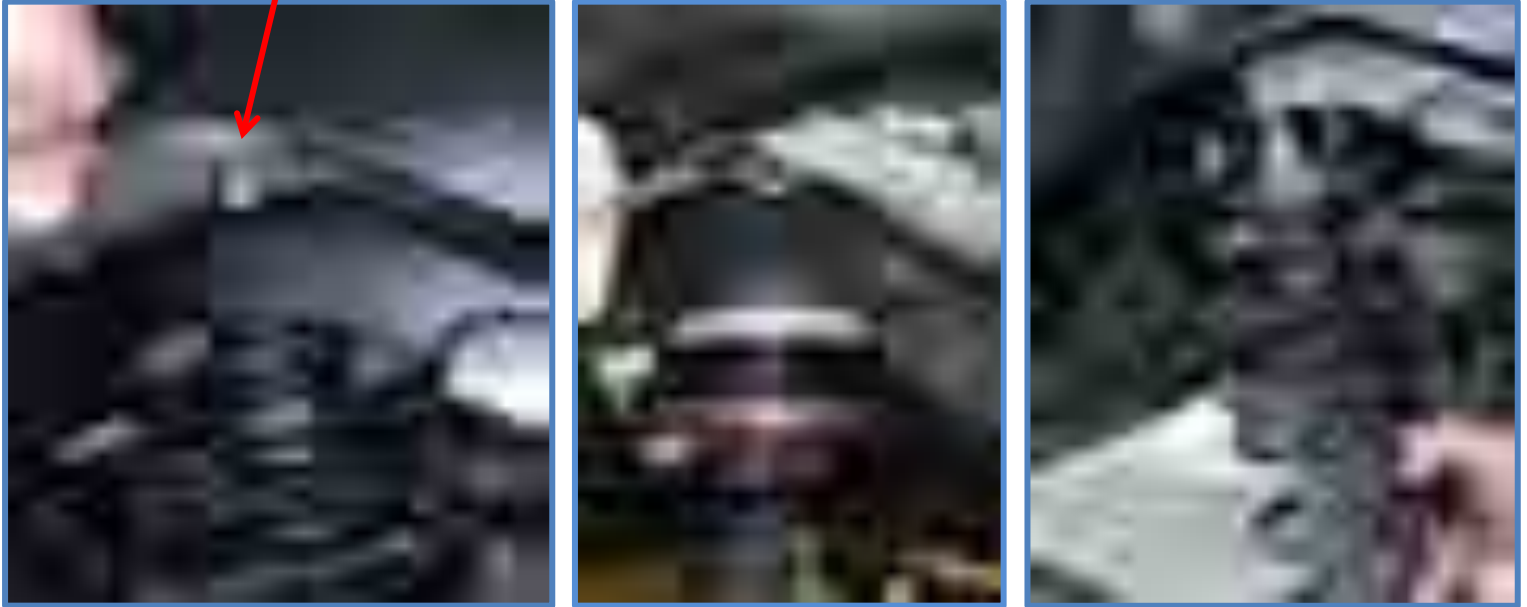

3. **Install King Shocks** – Be aware the shocks are side specific, make sure you are installing shocks on the proper side. See photos for proper orientation. Place the shock into the upper mount and install the 3/8 Heavy Duty washers (CW1701) and 3/8 nuts (CN2711) on upper mounting studs and tighten to 35 ft/lbs.

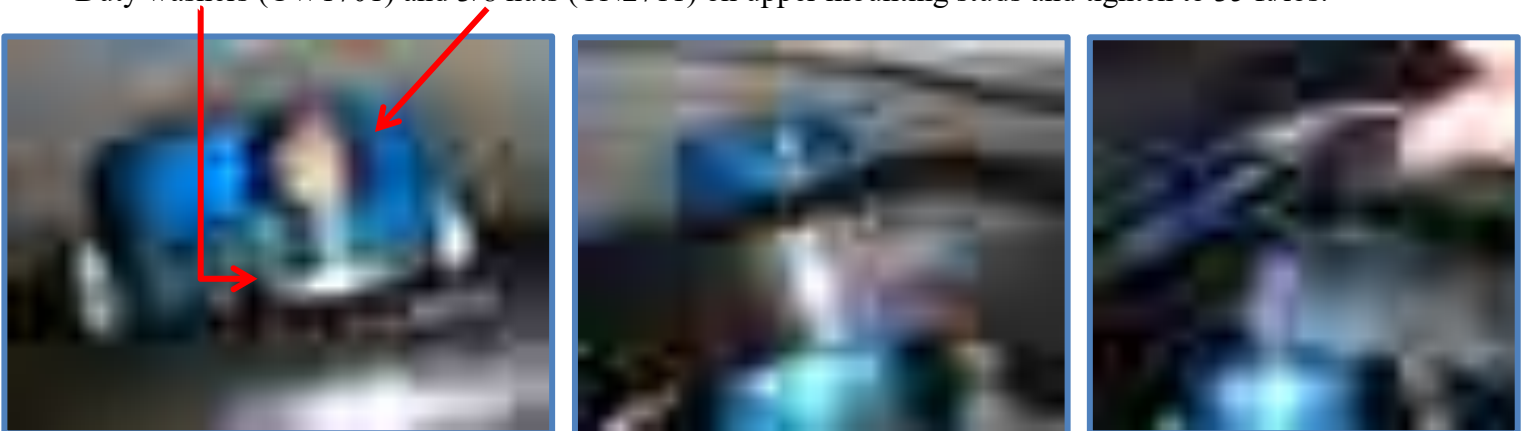

**Photo to the right shows the left side installed.**

**The hose and reservoir will be towards the rear.**

**The fitting at the end cap points in towards the frame and the hose will loop out to the reservoir.**



**IMPORTANT:** Read all instructions thoroughly from start to finish before beginning the install. Check parts list and make sure all parts are included in the kit. If the instructions are not properly followed severe frame, driveline and/or suspension damage may result. Check for frame and suspension damage prior to installation.

This kit does not require welding. Do not weld on any component. Welding may void the warranty and/or cause the product to fail. If any parts are missing, or for tech assistance; Contact King Off Road Racing Shocks: 714-530-8701 Most important after the install, Feel the difference and have fun.





**2021+ Ford Bronco 2.5 Rear Coilover**

King Shocks 12472 Edison Way Garden Grove, CA 92841  
714-530-8701 [www.kingshocks.com](http://www.kingshocks.com)

4. Place rod end into the lower mount and install the factory bolt and nut. Tighten lower bolt to factory specs.



5. **Mounting Reservoirs** – First attach the reservoir clamps to the reservoir brackets as shown below. Install the 1/4 X 1/2" BHCS (CB2420) with red locktite and tighten using a 5/32 Hex Key.

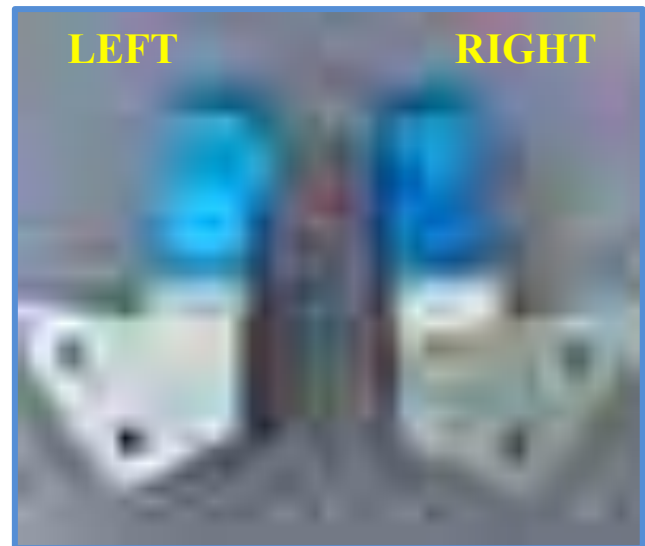
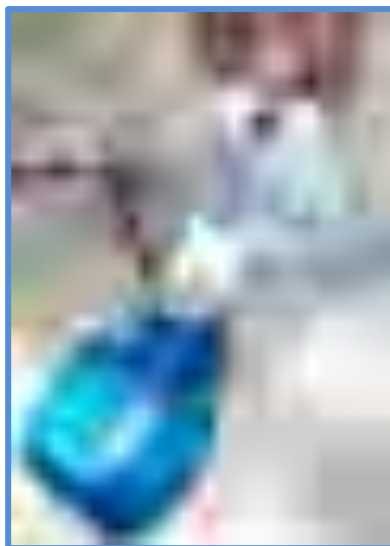

**IMPORTANT:** Read all instructions thoroughly from start to finish before beginning the install. Check parts list and make sure all parts are included in the kit. If the instructions are not properly followed severe frame, driveline and/or suspension damage may result. Check for frame and suspension damage prior to installation.

This kit does not require welding. Do not weld on any component. Welding may void the warranty and/or cause the product to fail. If any parts are missing, or for tech assistance; Contact King Off Road Racing Shocks: 714-530-8701 Most important after the install, Feel the difference and have fun.



## 2021+ Ford Bronco 2.5 Rear Coilover

King Shocks 12472 Edison Way Garden Grove, CA 92841  
714-530-8701 [www.kingshocks.com](http://www.kingshocks.com)

6. Place the reservoir bracket on the frame and line up holes in bracket with the holes in frame as shown below. Install the provided 3/8 X 1" bolts (CB4701) with HD washer (CW1701). Place the larger 3/8 fender washer on the back side followed by the 3/8 nut and tighten using a 9/16 wrench/socket.



7. Slide the reservoir into the reservoir clamp. Install the 1/4 X 1" bolts (CB1501) in the reservoir clamp and tighten using a 3/16 Allen wrench.



**IMPORTANT:** Read all instructions thoroughly from start to finish before beginning the install. Check parts list and make sure all parts are included in the kit. If the instructions are not properly followed severe frame, driveline and/or suspension damage may result. Check for frame and suspension damage prior to installation.

This kit does not require welding. Do not weld on any component. Welding may void the warranty and/or cause the product to fail. If any parts are missing, or for tech assistance; Contact King Off Road Racing Shocks: 714-530-8701 Most important after the install, Feel the difference and have fun.



**2021+ Ford Bronco 2.5 Rear Coilover**

King Shocks 12472 Edison Way Garden Grove, CA 92841  
714-530-8701 [www.kingshocks.com](http://www.kingshocks.com)

**Final install should look similar to photos below.**



**DOUBLE CHECK ALL HARDWARE:**

Make sure everything is installed correctly and all hardware is tight before reinstalling tires. Install tires, remove jack stands and lower vehicle to the ground. Recheck all hardware and lug nuts after 100 miles and periodically after that as part of routine maintenance.



King Shocks  
12472 Edison Way  
Garden Grove, CA 92841  
714-530-8701  
[www.kingshocks.com](http://www.kingshocks.com)

**IMPORTANT:** Read all instructions thoroughly from start to finish before beginning the install. Check parts list and make sure all parts are included in the kit. If the instructions are not properly followed severe frame, driveline and/or suspension damage may result. Check for frame and suspension damage prior to installation.

This kit does not require welding. Do not weld on any component. Welding may void the warranty and/or cause the product to fail. If any parts are missing, or for tech assistance; Contact King Off Road Racing Shocks: 714-530-8701  
Most important after the install, Feel the difference and have fun.



**2021+ Ford Bronco 2.5 Rear Coilover**

King Shocks 12472 Edison Way Garden Grove, CA 92841  
714-530-8701 [www.kingshocks.com](http://www.kingshocks.com)

**Rear Parts List:**

- 2 – 2.5 Rear Coilover Shocks (25001-393)
- 2 – Reservoir Brackets (25048-064/065)
- 1 – Hardware Kit (KH02-182)

**Tools Required:**

- Floor Jack/Jack Stands
- Metric Wrench/Socket Set
- Standard Wrench/Socket Set

**2021 Ford Bronco**  
OEM PERFORMANCE SERIES



**REAR:** With the vehicle on level ground, block the front tires. Using a floor jack, raise the rear end and support the frame rails with jack stands for safety. Remove rear tires. **NOTE: Never work under an unsupported vehicle.**

1. Remove the existing shocks by removing the lower mounting bolt and upper mount nuts. First remove the lower bolt using a 27mm socket. Support the axle with a jack or jack stands when removing the bolt.

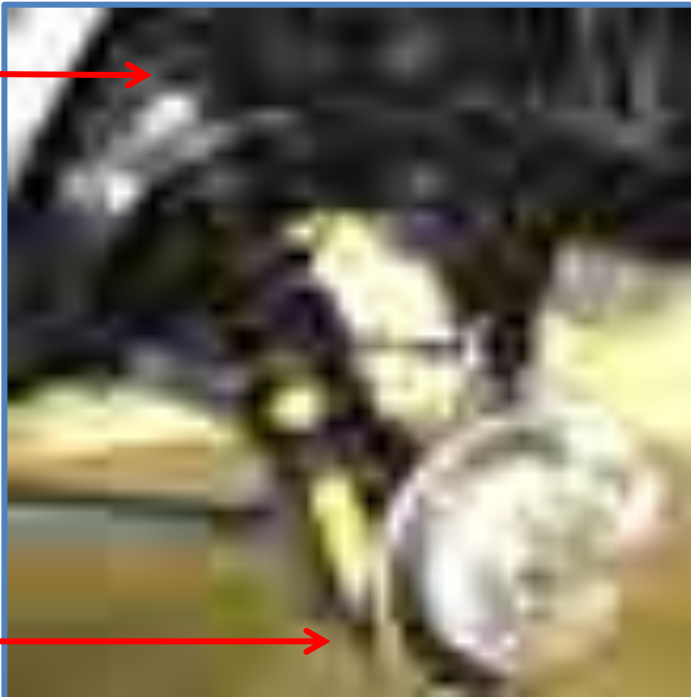

**IMPORTANT:** Read all instructions thoroughly from start to finish before beginning the install. Check parts list and make sure all parts are included in the kit. If the instructions are not properly followed severe frame, driveline and/or suspension damage may result. Check for frame and suspension damage prior to installation.

This kit does not require welding. Do not weld on any component. Welding may void the warranty and/or cause the product to fail. If any parts are missing, or for tech assistance; Contact King Off Road Racing Shocks: 714-530-8701 Most important after the install, Feel the difference and have fun.



## 2021+ Ford Bronco 2.5 Rear Coilover

King Shocks 12472 Edison Way Garden Grove, CA 92841  
714-530-8701 [www.kingshocks.com](http://www.kingshocks.com)

2. Remove the nuts from the upper mount using a 15mm wrench/socket or ratchet wrench, then remove shocks from vehicle.

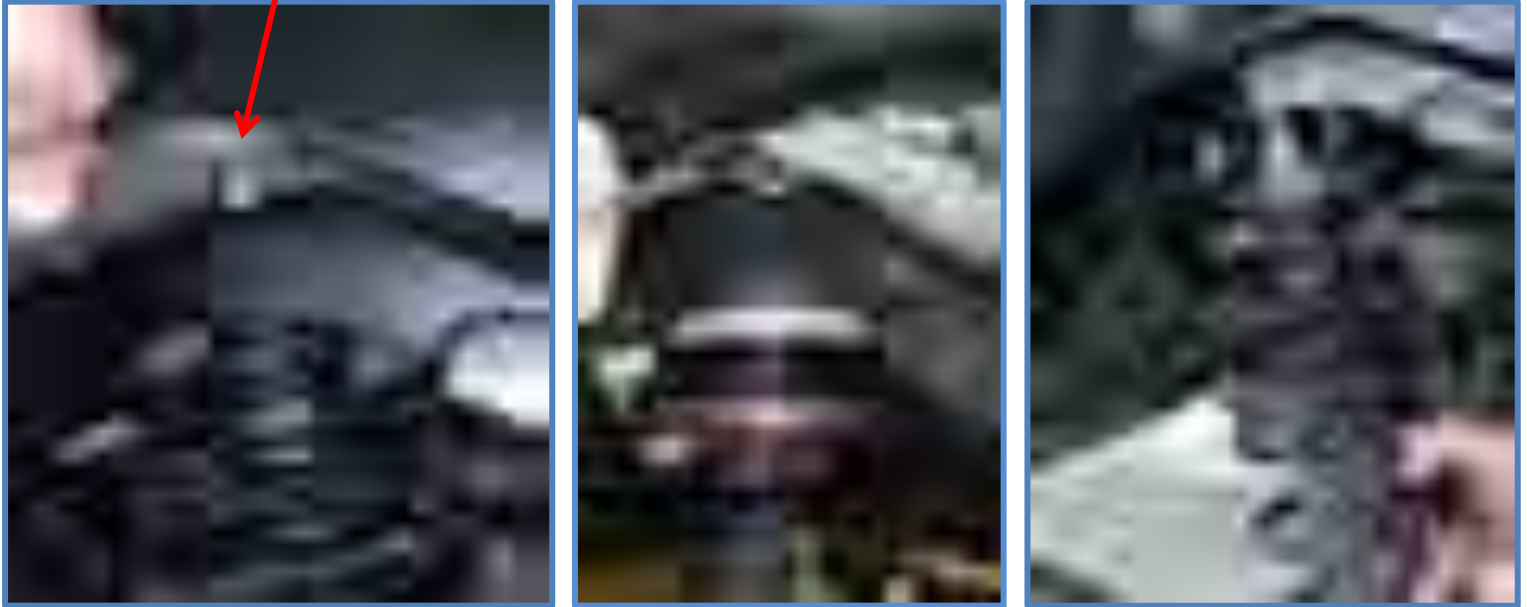

3. **Install King Shocks** – Be aware the shocks are side specific, make sure you are installing shocks on the proper side. See photos for proper orientation. Place the shock into the upper mount and install the 3/8 Heavy Duty washers (CW1701) and 3/8 nuts (CN2711) on upper mounting studs and tighten to 35 ft/lbs.

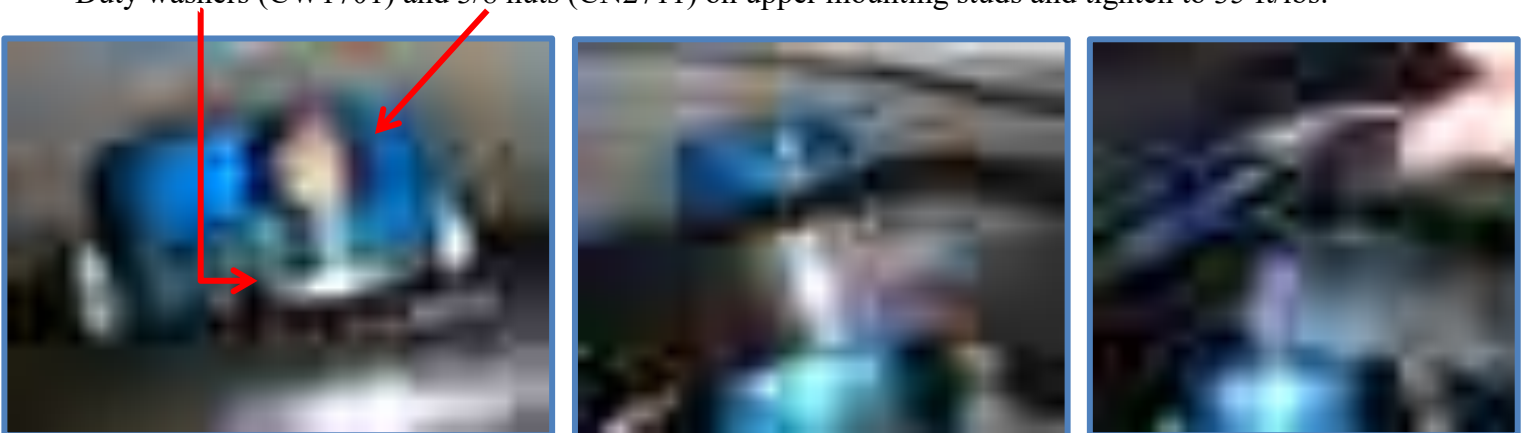

Photo to the right shows the left side installed.

The hose and reservoir will be towards the rear.

The fitting at the end cap points in towards the frame and the hose will loop out to the reservoir.



**IMPORTANT:** Read all instructions thoroughly from start to finish before beginning the install. Check parts list and make sure all parts are included in the kit. If the instructions are not properly followed severe frame, driveline and/or suspension damage may result. Check for frame and suspension damage prior to installation.

This kit does not require welding. Do not weld on any component. Welding may void the warranty and/or cause the product to fail. If any parts are missing, or for tech assistance; Contact King Off Road Racing Shocks: 714-530-8701 Most important after the install, Feel the difference and have fun.



**2021+ Ford Bronco 2.5 Rear Coilover**

King Shocks 12472 Edison Way Garden Grove, CA 92841  
714-530-8701 [www.kingshocks.com](http://www.kingshocks.com)

4. Place rod end into the lower mount and install the factory bolt and nut. Tighten lower bolt to factory specs.



5. **Mounting Reservoirs** – First attach the reservoir clamps to the reservoir brackets as shown below. Install the 1/4 X 1/2" BHCS (CB2420) with red locktite and tighten using a 5/32 Hex Key.

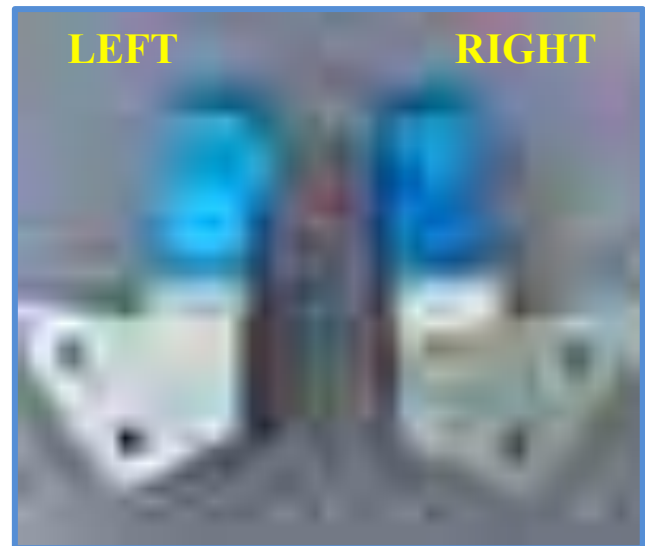
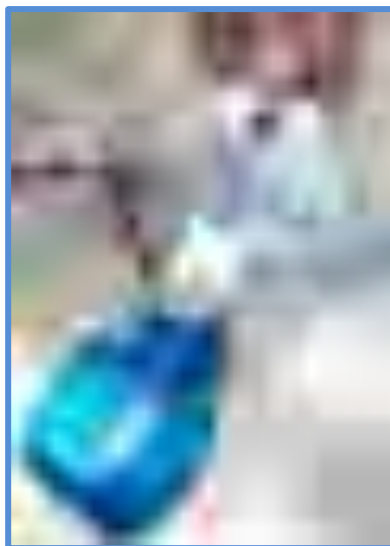

**IMPORTANT:** Read all instructions thoroughly from start to finish before beginning the install. Check parts list and make sure all parts are included in the kit. If the instructions are not properly followed severe frame, driveline and/or suspension damage may result. Check for frame and suspension damage prior to installation.

This kit does not require welding. Do not weld on any component. Welding may void the warranty and/or cause the product to fail. If any parts are missing, or for tech assistance; Contact King Off Road Racing Shocks: 714-530-8701 Most important after the install, Feel the difference and have fun.



## 2021+ Ford Bronco 2.5 Rear Coilover

King Shocks 12472 Edison Way Garden Grove, CA 92841  
714-530-8701 [www.kingshocks.com](http://www.kingshocks.com)

6. Place the reservoir bracket on the frame and line up holes in bracket with the holes in frame as shown below. Install the provided 3/8 X 1" bolts (CB4701) with HD washer (CW1701). Place the larger 3/8 fender washer on the back side followed by the 3/8 nut and tighten using a 9/16 wrench/socket.

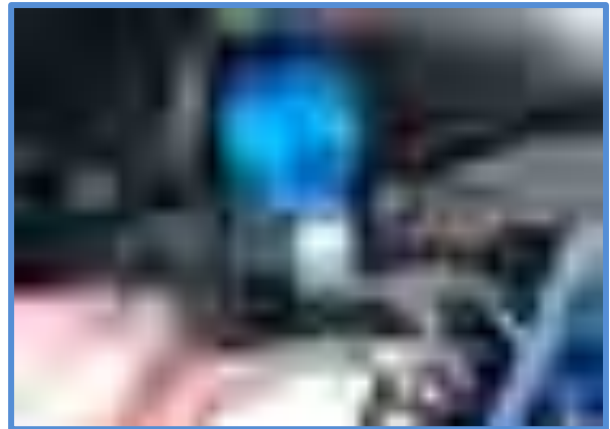

7. Slide the reservoir into the reservoir clamp. Install the 1/4 X 1" bolts (CB1501) in the reservoir clamp and tighten using a 3/16 Allen wrench.



**IMPORTANT:** Read all instructions thoroughly from start to finish before beginning the install. Check parts list and make sure all parts are included in the kit. If the instructions are not properly followed severe frame, driveline and/or suspension damage may result. Check for frame and suspension damage prior to installation.

This kit does not require welding. Do not weld on any component. Welding may void the warranty and/or cause the product to fail. If any parts are missing, or for tech assistance; Contact King Off Road Racing Shocks: 714-530-8701 Most important after the install, Feel the difference and have fun.



**2021+ Ford Bronco 2.5 Rear Coilover**

King Shocks 12472 Edison Way Garden Grove, CA 92841  
714-530-8701 [www.kingshocks.com](http://www.kingshocks.com)

**Final install should look similar to photos below.**



**DOUBLE CHECK ALL HARDWARE:**

Make sure everything is installed correctly and all hardware is tight before reinstalling tires. Install tires, remove jack stands and lower vehicle to the ground. Recheck all hardware and lug nuts after 100 miles and periodically after that as part of routine maintenance.



King Shocks  
12472 Edison Way  
Garden Grove, CA 92841  
714-530-8701  
[www.kingshocks.com](http://www.kingshocks.com)

**IMPORTANT:** Read all instructions thoroughly from start to finish before beginning the install. Check parts list and make sure all parts are included in the kit. If the instructions are not properly followed severe frame, driveline and/or suspension damage may result. Check for frame and suspension damage prior to installation.

This kit does not require welding. Do not weld on any component. Welding may void the warranty and/or cause the product to fail. If any parts are missing, or for tech assistance; Contact King Off Road Racing Shocks: 714-530-8701  
Most important after the install, Feel the difference and have fun.





## **M A N U F A C T U R I N G**

**2007-2018 JEEP WRANGLER JK / JKU  
2018-2019 JEEP WRANGLER JL / JLU  
2020 JEEP GLADIATOR JT**

**2019**



**EVO Manufacturing was founded in 2008 by Mel Wade, an avid 4 wheeler/master mechanic and Andrew Perle, raised in desert racing and a mechanical engineer. The 2 saw a need for well engineered, properly tuned suspension systems and accessories in the Jeep Wrangler market. They paired to do just that. Through their experience, EVO Manufacturing (EVO MFG) solidifies performance and quality. Driven by industry leaders, engineered and tested like no other, EVO MFG's focus on innovation is unmatched. Our efforts are guided by bringing the highest quality and performance minded products to you. Engineered and manufactured in the USA, proven worldwide. EVO MFG is unsurpassed!**



**1835 W Commonwealth Ave, Fullerton, CA 92833  
Phone: (714) 879-8913      [www.EVOMFG.com](http://www.EVOMFG.com)**

# TABLE OF CONTENTS

**2018-2019 JEEP WRANGLER JL/JLU  
SUSPENSION SYSTEMS ..... 4-9**

**2018-2019 JEEP WRANGLER JL/JLU  
SUSPENSION COMPONENTS & UPGRADES ..... 10-12**

**2020 JEEP GLADIATOR JT  
SUSPENSION SYSTEMS ..... 13-16**

**2020 JEEP GLADIATOR JT  
COMPONENTS & UPGRADES ..... 17-18**

**2007-2018 JEEP WRANGLER JK/JKU  
SUSPENSION SYSTEMS ..... 19-25**

**2007-2018 JEEP JK/JKU  
COMPONENTS & UPGRADES ..... 26-27**

**2018-2019 JEEP WRANGLER JL/JLU  
2020 JEEP GLADIATOR JT BUMPERS,  
TIRE CARRIERS & ARMOR ..... 28-32**

**2007-2018 JEEP WRANGLER JK/JKU  
BUMPERS AND TIRE CARRIERS ..... 33**

**2007-2018 JEEP WRANGLER JK/JKU  
ARMOR ..... 35**

**2007-2018 JEEP WRANGLER JK/JKU  
PROTEK ARMOR AND SKIDS ..... 36-37**

**2007-2018 JEEP WRANGLER JK / JKU  
ACCESSORIES ..... 38**

# SUSPENSION SYSTEMS

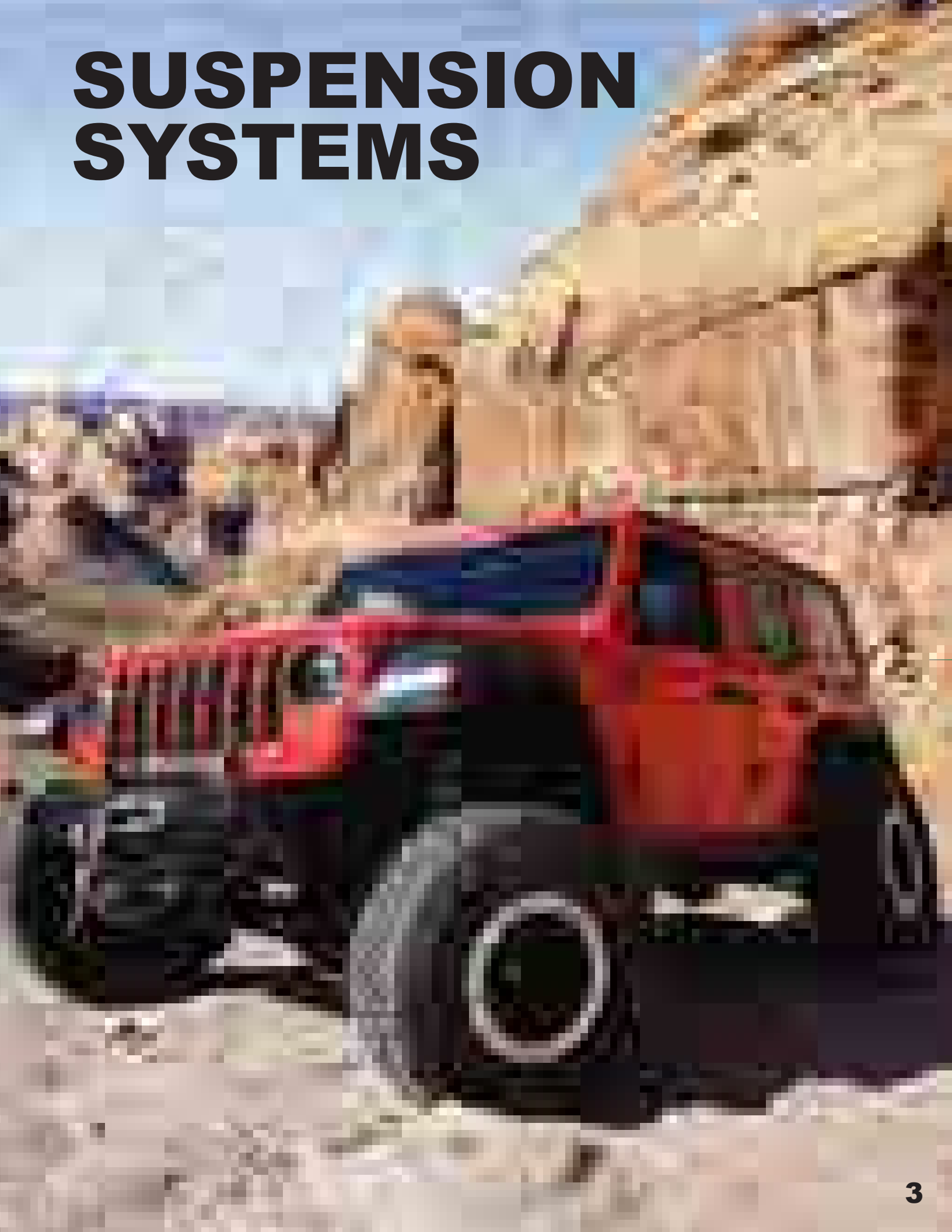

# 2018-2019 JEEP WRANGLER JL/JLU SUSPENSION SYSTEMS

## JL/JLU SUSPENSION SYSTEM STAGE INFORMATION

- |                 |   |
|-----------------|---|
| <b>STAGE 1:</b> | Includes the basic components to lift your JL/JLU   |
| <b>STAGE 2:</b> | Includes all components of stage 1 with the addition of adjustable front Lower enforcer control arms. This allows for front caster adjustments.         |
| <b>STAGE 3:</b> | Includes all components of stage 2 with the addition of adjustable rear upper Enforcer control arms. This allows for rear axle pinion angle adjustments |
| <b>STAGE 4:</b> | Includes all component of stage 1 with the addition of "all 8"<br>(Front and rear upper and lower) adjustable enforcer control arms.                    |

Plus ("P") kits include the addition of front and rear adjustable track bars  
"K" kits include a full set, front and rear king 2.5" dia remote reservoir shocks.  
PRO kits are front and rear coilover suspension systems

# 2018-2019 JEEP WRANGLER JL/JLU SUSPENSION SYSTEMS

## HIGH CLEARANCE PRO COILOVER LONG ARM

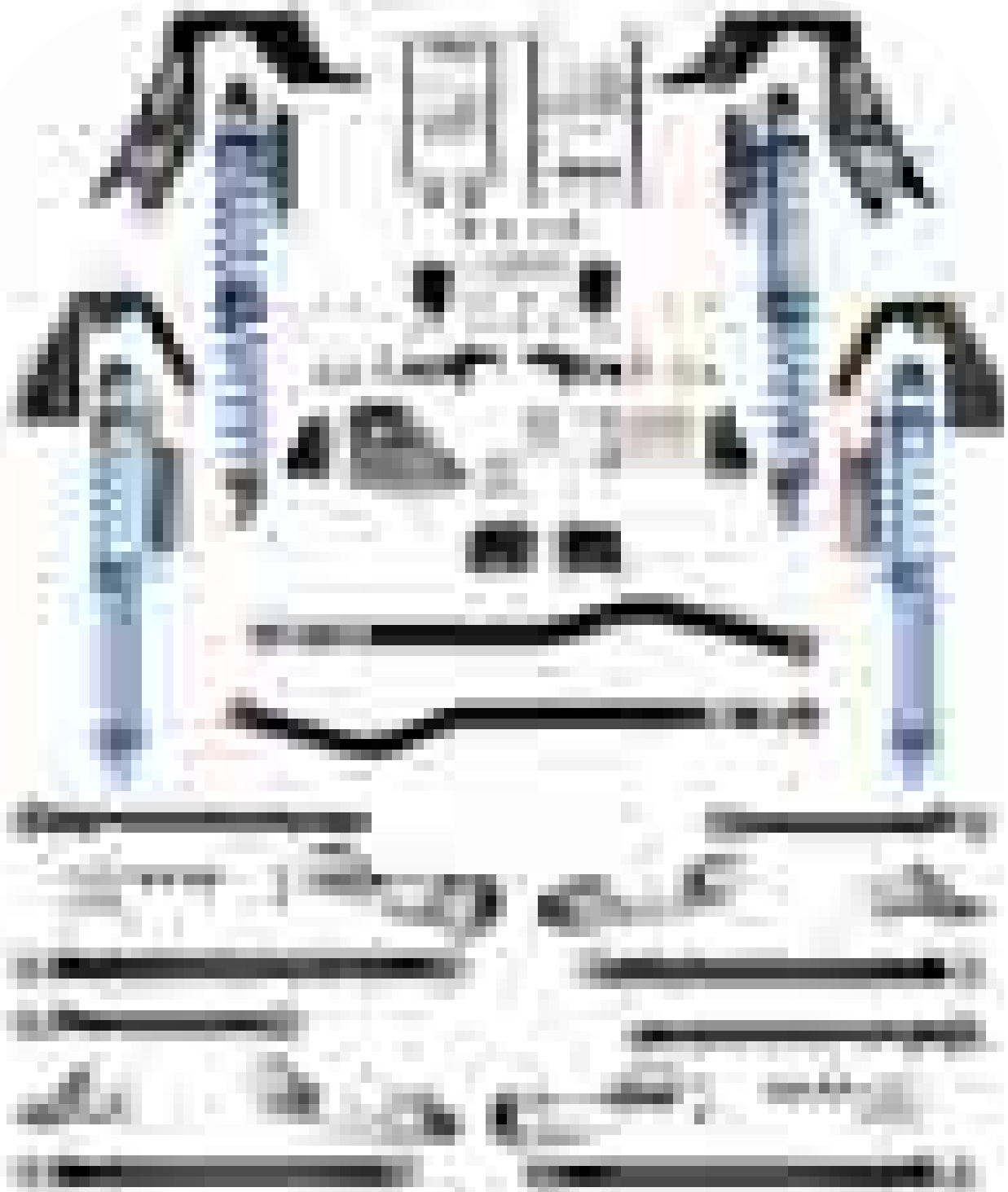

EVO-242B JLU HIGH CLEARANCE PRO PLUS COILOVER LONG ARM  
EVO-242BP JLU HIGH CLEARANCE PRO PLUS COILOVER LONG ARM PLUS

Compression adjust coilovers available - special order/leadtime

# 2018-2019 JEEP WRANGLER JL/JLU SUSPENSION SYSTEMS

## ENFORCER PRO COILOVER



### JL / JLU ENFORCER PRO

<b>STAGE 1</b>	EVO-241B-1	ENFORCER PRO STAGE 1
	EVO-241B-1P	ENFORCER PRO STAGE 1 PLUS
<b>STAGE 2</b>	EVO-241B-2	ENFORCER PRO STAGE 2
	EVO-241B-2P	ENFORCER PRO STAGE 2 PLUS
<b>STAGE 3</b>	EVO-241B-3	ENFORCER PRO STAGE 3
	EVO-241B-3P	ENFORCER PRO STAGE 3 PLUS
<b>STAGE 4</b>	EVO-241B-4	ENFORCER PRO STAGE 4
	EVO-241B-4P	ENFORCER PRO STAGE 4 PLUS

Compression adjust coilovers available- special order/leadtime



# 2018-2019 JEEP WRANGLER JL/JLU SUSPENSION SYSTEMS

## HIGH CLEARANCE LONG ARM 2.5" 3.5" OR 4.5" LIFT HEIGHTS



### JL / JLU HIGH CLEARANCE LONG ARM

<b>2.5"</b>	EVO-3015	2.5" HIGH CLEARANCE LONG ARM
	EVO-3015P	2.5" HIGH CLEARANCE LONG ARM PLUS
	EVO-3015K	2.5" HIGH CLEARANCE LONG ARM, W/ 2.5" DIA KING RESERVOIR SHOCKS
	EVO-3015PK	2.5" HIGH CLEARANCE LONG ARM PLUS, W/ 2.5" DIA KING RESERVOIR SHOCKS
<b>3.5"</b>	EVO-3016	3.5" HIGH CLEARANCE LONG ARM
	EVO-3016P	3.5" HIGH CLEARANCE LONG ARM PLUS
	EVO-3016K	3.5" HIGH CLEARANCE LONG ARM, W/ 2.5" DIA KING RESERVOIR SHOCKS
	EVO-3016PK	3.5" HIGH CLEARANCE LONG ARM PLUS, W/ 2.5" DIA KING RESERVOIR SHOCKS
<b>4.5"</b>	EVO-3056	4.5" HIGH CLEARANCE LONG ARM
	EVO-3056P	4.5" HIGH CLEARANCE LONG ARM PLUS
	EVO-3056K	4.5" HIGH CLEARANCE LONG ARM, W/ 2.5" DIA KING RESERVOIR SHOCKS
	EVO-3056PK	4.5" HIGH CLEARANCE LONG ARM PLUS, W/ 2.5" DIA KING RESERVOIR SHOCKS

Compression adjust shocks available- special order/leadtime

# 2018-2019 JEEP WRANGLER JL/JLU SUSPENSION SYSTEMS

## ENFORCER SYSTEMS 2.5" 3.5" OR 4.5" LIFT HEIGHTS



### JL / JLU ENFORCER SYSTEMS

<b>2.5"</b>	EVO-3011S4	2.5" ENFORCER STAGE 4
	EVO-3011S4P	2.5" ENFORCER STAGE 4 PLUS
	EVO-3011S4K	2.5" ENFORCER STAGE 4, W/ 2.5" DIA KING RESERVOIR SHOCKS
	EVO-3011S4PK	2.5" ENFORCER STAGE 4 PLUS, W/ 2.5" DIA KING RESERVOIR SHOCKS
<b>3.5"</b>	EVO-3013S4	3.5" ENFORCER STAGE 4
	EVO-3013S4P	3.5" ENFORCER STAGE 4 PLUS
	EVO-3013S4K	3.5" ENFORCER STAGE 4, W/ 2.5" DIA KING RESERVOIR SHOCKS
	EVO-3013S4PK	3.5" ENFORCER STAGE 4 PLUS, W/ 2.5" DIA KING RESERVOIR SHOCKS
<b>4.5"</b>	EVO-3054S4	4.5" ENFORCER STAGE 4
	EVO-3054S4P	4.5" ENFORCER STAGE 4 PLUS
	EVO-3054S4K	4.5" ENFORCER STAGE 4, W/ 2.5" DIA KING RESERVOIR SHOCKS
	EVO-3054S4PK	4.5" ENFORCER STAGE 4 PLUS, W/ 2.5" DIA KING RESERVOIR SHOCKS

STAGE 1 "S1", STAGE 2 "S2" STAGE 3 "S3" ALSO AVAILABLE.  
REFERENCE STAGE INFORMATION ON PAGE 4.  
COMPRESSION ADJUST SHOCKS AVAILABLE- SPECIAL ORDER/LEADTIME

# 2018-2019 JEEP WRANGLER JL/JLU SUSPENSION SYSTEMS

## ENFORCER OVERLAND 2.5" 3.5" OR 4.5" LIFT HEIGHTS



### JL / JLU ENFORCER OVERLAND SYSTEMS

<b>2.5"</b>	EVO-3012S4	2.5" ENFORCER OVERLAND STAGE 4
	EVO-3012S4P	2.5" ENFORCER OVERLAND STAGE 4 PLUS
	EVO-3012S4K	2.5" ENFORCER OVERLAND STAGE 4, W/ 2.5" DIA KING RESERVOIR SHOCKS
	EVO-3012S4PK	2.5" ENFORCER OVERLAND STAGE 4 PLUS, W/ 2.5" DIA KING RESERVOIR SHOCKS
<b>3.5"</b>	EVO-3014S4	3.5" ENFORCER OVERLAND STAGE 4
	EVO-3014S4P	3.5" ENFORCER OVERLAND STAGE 4 PLUS
	EVO-3014S4K	3.5" ENFORCER OVERLAND STAGE 4, W/ 2.5" DIA KING RESERVOIR SHOCKS
	EVO-3014S4PK	3.5" ENFORCER OVERLAND STAGE 4 PLUS, W/ 2.5" DIA KING RESERVOIR SHOCKS
<b>4.5"</b>	EVO-3055S4	4.5" ENFORCER OVERLAND STAGE 4
	EVO-3055S4P	4.5" ENFORCER OVERLAND STAGE 4 PLUS
	EVO-3055S4K	4.5" ENFORCER OVERLAND STAGE 4, W/ 2.5" DIA KING RESERVOIR SHOCKS
	EVO-3055S4PK	4.5" ENFORCER OVERLAND STAGE 4 PLUS, W/ 2.5" DIA KING RESERVOIR SHOCKS

STAGE 1 "S1", STAGE 2 "S2" STAGE 3 "S3" ALSO AVAILABLE.  
REFERENCE STAGE INFORMATION ON PAGE 4.  
COMPRESSION ADJUST SHOCKS AVAILABLE- SPECIAL ORDER/LEADTIME

# 2018-2019 JEEP WRANGLER JL/JLU SUSPENSION COMPONENTS & UPGRADES



EVO-3010 HIGH CLEARANCE LONG ARM UPGRADE



EVO-3006B FRONT LOWER ADJUSTABLE  
ENFORCER CONTROL ARMS



EVO-3007B FRONT UPPER ADJUSTABLE  
ENFORCER CONTROL ARMS

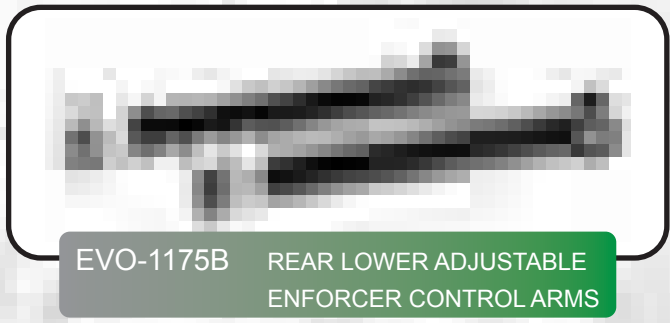

EVO-1175B REAR LOWER ADJUSTABLE  
ENFORCER CONTROL ARMS

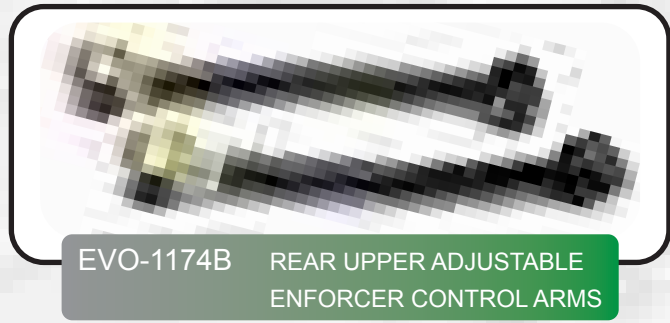

EVO-1174B REAR UPPER ADJUSTABLE  
ENFORCER CONTROL ARMS

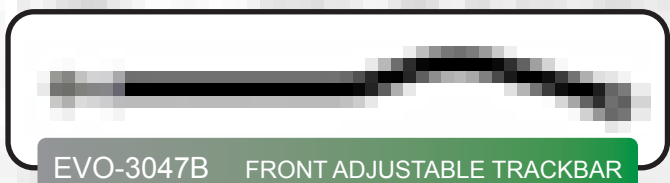

EVO-3047B FRONT ADJUSTABLE TRACKBAR

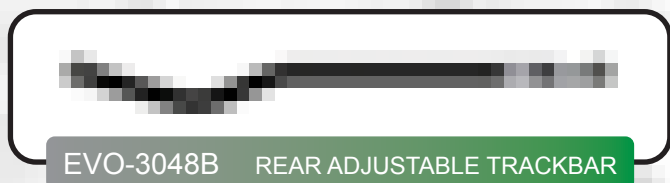

EVO-3048B REAR ADJUSTABLE TRACKBAR

# 2018-2019 JEEP WRANGLER JL/JLU SUSPENSION COMPONENTS & UPGRADES

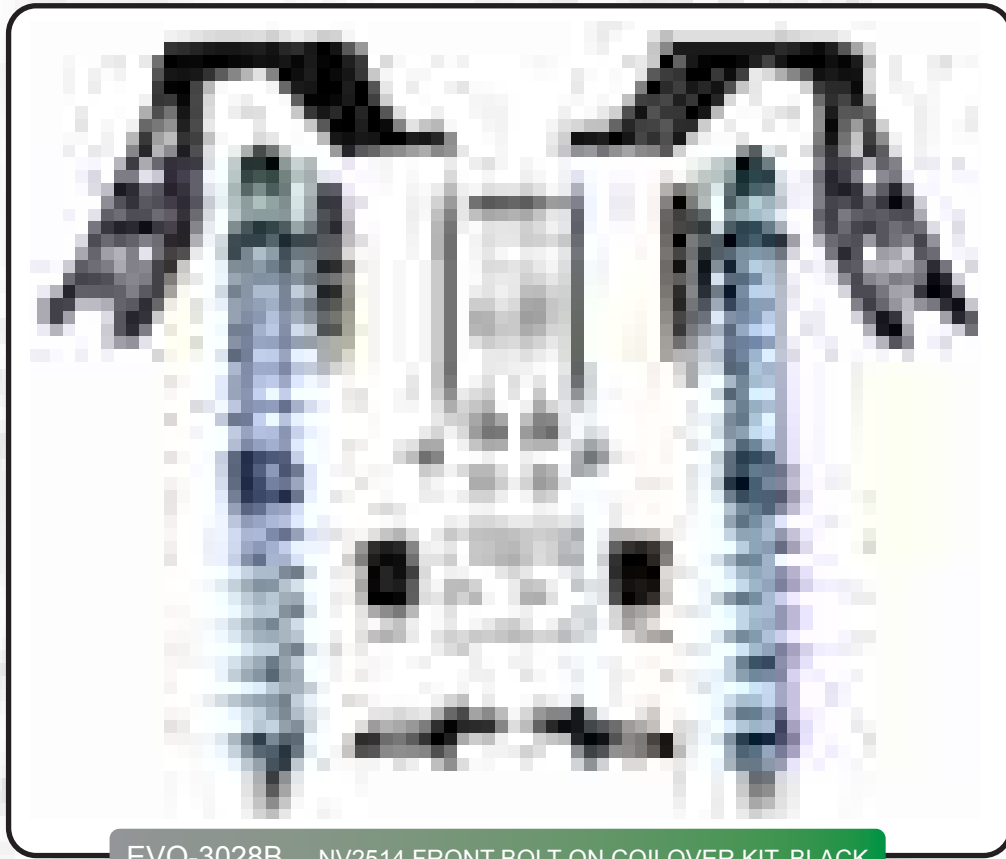

EVO-3028B NV2514 FRONT BOLT-ON COILOVER KIT, BLACK



EVO-3029B NV2514 REAR BOLT-ON COILOVER KIT, BLACK

COMPRESSION ADJUST COILOVERS AVAILABLE- SPECIAL ORDER/LEADTIME

# 2018-2019 JEEP WRANGLER JL/JLU SUSPENSION COMPONENTS & UPGRADES

## PLUSH RIDE COILS

2.5"	EVO-3021	2.5" FRONT PLUSH RIDE COILS, PAIR
	EVO-3022	2.5" REAR PLUSH RIDE COILS, PAIR
3.5"	EVO-3023	3.5" FRONT PLUSH RIDE COILS, PAIR
	EVO-3024	3.5" REAR PLUSH RIDE COILS, PAIR
4.5"	EVO-3052	4.5" FRONT PLUSH RIDE COILS, PAIR
	EVO-3053	4.5" REAR PLUSH RIDE COILS, PAIR

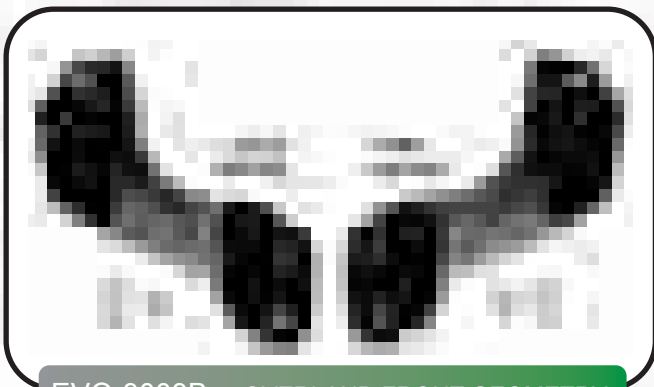
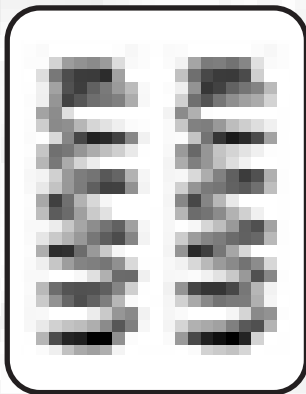
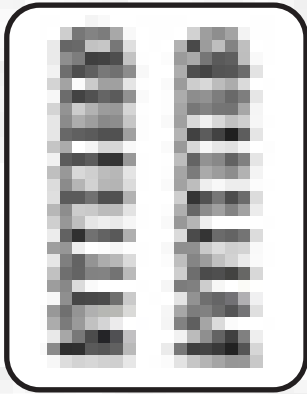

EVO-3003B OVERLAND FRONT GEOMETRY CORRECTION BRACKETS



EVO-1077 FRONT BUMPSTOP EXTENSIONS

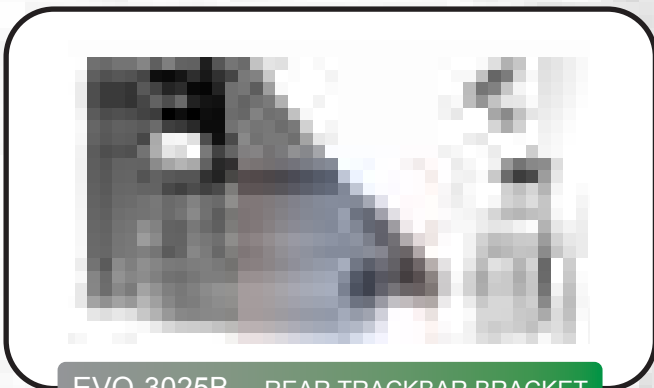

EVO-3025B REAR TRACKBAR BRACKET

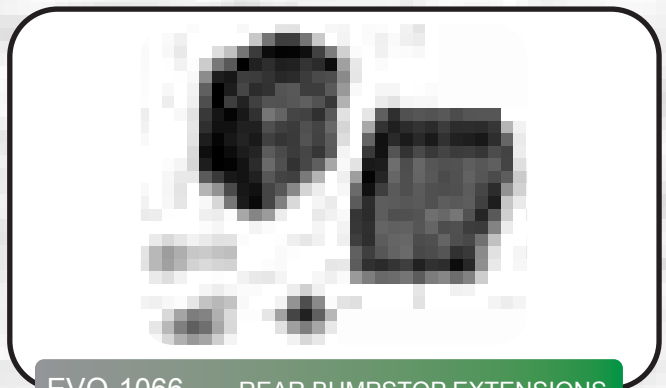

EVO-1066 REAR BUMPSTOP EXTENSIONS

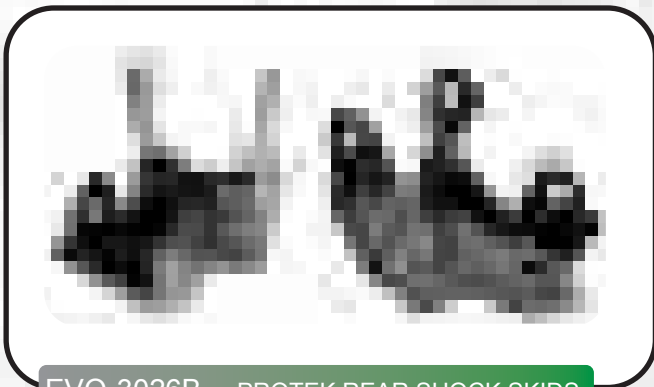

EVO-3026B PROTEK REAR SHOCK SKIDS



EVO-3027B PROTEK FRONT SHOCK RELOCATION BRACKETS, BLACK

# 2020 JEEP GLADIATOR JT SUSPENSION SYSTEMS



## GLADIATOR JT SUSPENSION SYSTEM STAGE INFORMATION

- |                 |   |
|-----------------|---|
| <b>STAGE 1:</b> | Includes the basic components to lift your Gladiator JT   |
| <b>STAGE 2:</b> | Includes all components of stage 1 with the addition of adjustable front Lower enforcer control arms. This allows for front caster adjustments.         |
| <b>STAGE 3:</b> | Includes all components of stage 2 with the addition of adjustable rear upper Enforcer control arms. This allows for rear axle pinion angle adjustments |
| <b>STAGE 4:</b> | Includes all component of stage 1 with the addition of "all 8" (Front and rear upper and lower) adjustable enforcer control arms.                       |

Plus Kits "P" include the addition of front and rear adjustable track bars  
"K" Kits include a full set, front and rear king 2.5" dia remote reservoir shocks.  
PRO Kits are front and rear coilover suspension systems  
Fusion Kits are front coilover rear coil and shock suspension systems

# 2020 JEEP GLADIATOR JT SUSPENSION SYSTEMS

## GLADIATOR JT ENFORCER FUSION SYSTEMS 4.5" OR 6.5" LIFT HEIGHTS



EVO-248BS4P  
EVO-249BS4P

4.5" ENFORCER FUSION STAGE 4 PLUS  
6.5" ENFORCER FUSION STAGE 4 PLUS



# 2020 JEEP GLADIATOR JT SUSPENSION SYSTEMS

## GLADIATOR JT ENFORCER SYSTEMS 2.5" 4.5" 6.5" LIFT HEIGHTS

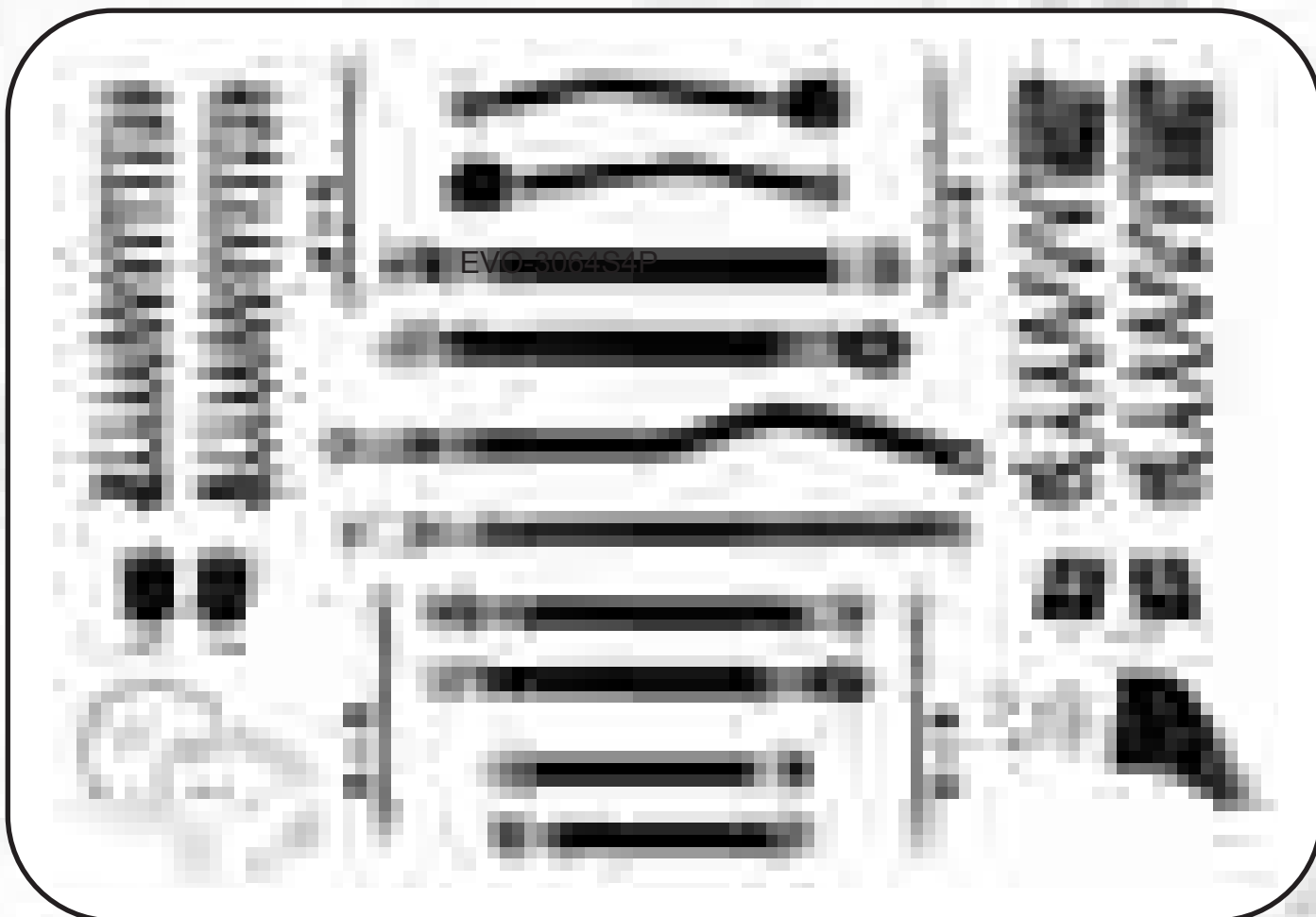

### GLADIATOR JT ENFORCER SYSTEMS

<b>2.5"</b>	EVO-3060S4	2.5" ENFORCER STAGE 4
	EVO-3060S4P	2.5" ENFORCER STAGE 4 PLUS
	EVO-3060S4K	2.5" ENFORCER STAGE 4, W/ 2.5" DIA KING RESERVOIR SHOCKS
	EVO-3060S4PK	2.5" ENFORCER STAGE 4 PLUS, W/ 2.5" DIA KING RESERVOIR SHOCKS
<b>4.5"</b>	EVO-3062S4	4.5" ENFORCER STAGE 4
	EVO-3062S4P	4.5" ENFORCER STAGE 4 PLUS
	EVO-3062S4K	4.5" ENFORCER STAGE 4, W/ 2.5" DIA KING RESERVOIR SHOCKS
	EVO-3062S4PK	4.5" ENFORCER STAGE 4 PLUS, W/ 2.5" DIA KING RESERVOIR SHOCKS
<b>6.5"</b>	EVO-3064S4	6.5" ENFORCER STAGE 4
	EVO-3064S4P	6.5" ENFORCER STAGE 4 PLUS
	EVO-3064S4K	6.5" ENFORCER STAGE 4, W/ 2.5" DIA KING RESERVOIR SHOCKS
	EVO-3064S4PK	6.5" ENFORCER STAGE 4 PLUS, W/ 2.5" DIA KING RESERVOIR SHOCKS

STAGE 1 "S1", STAGE 2 "S2" STAGE 3 "S3" ALSO AVAILABLE.  
REFERENCE STAGE INFORMATION ON PAGE 13.  
COMPRESSION ADJUST SHOCKS AVAILABLE- SPECIAL ORDER/LEADTIME

# 2020 JEEP GLADIATOR JT SUSPENSION SYSTEMS

## GLADIATOR JT ENFORCER OVERLAND SYSTEMS 2.5" 4.5" 6.5" LIFT HEIGHTS

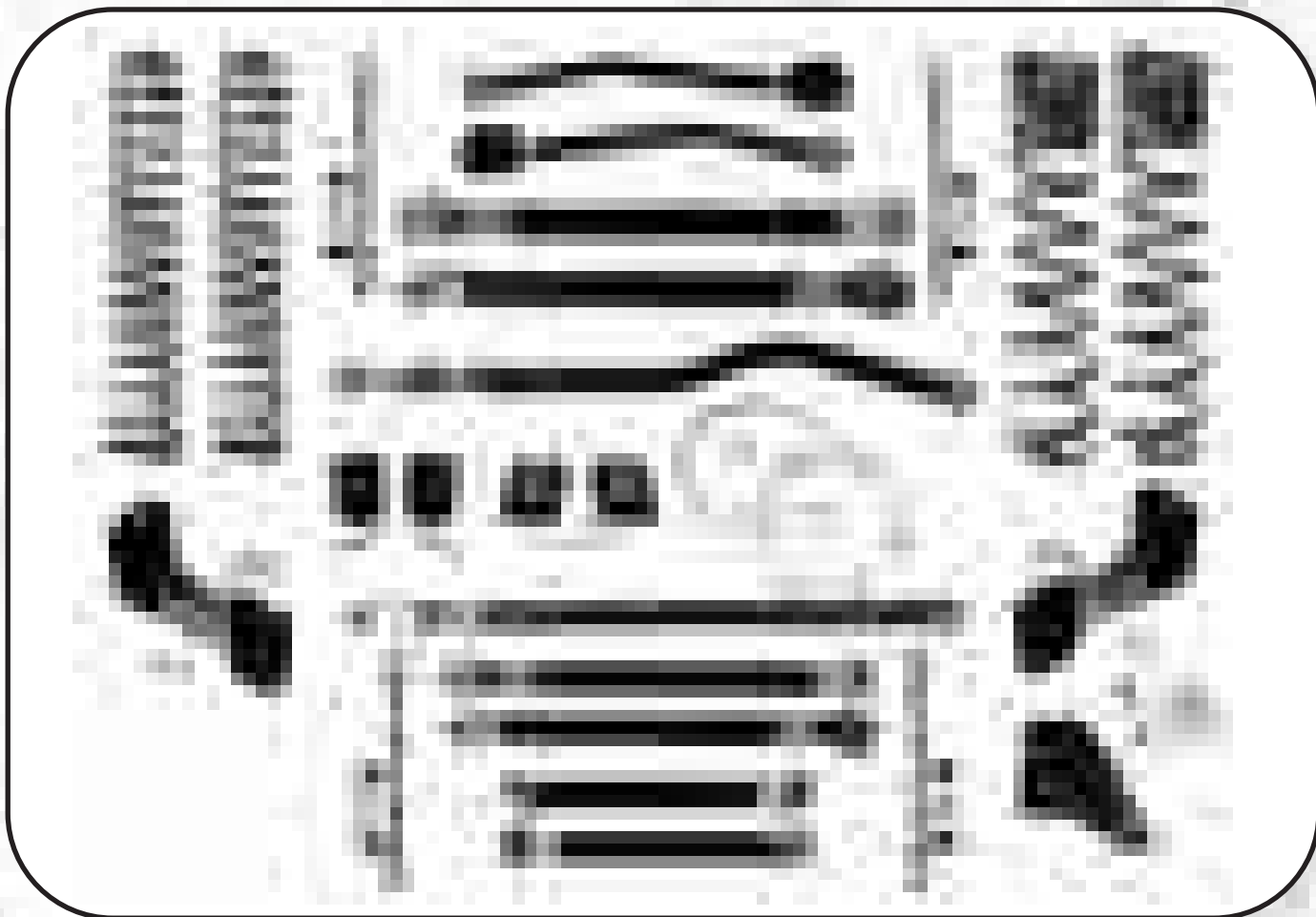

### GLADIATOR JT ENFORCER OVERLAND SYSTEMS

<b>2.5"</b>	EVO-3061S4	2.5" ENFORCER OVERLAND STAGE 4
	EVO-3061S4P	2.5" ENFORCER OVERLAND STAGE 4 PLUS
	EVO-3061S4K	2.5" ENFORCER OVERLAND STAGE 4, W/ 2.5" DIA KING RESERVOIR SHOCKS
	EVO-3061S4PK	2.5" ENFORCER OVERLAND STAGE 4 PLUS, W/ 2.5" DIA KING RESERVOIR SHOCKS
<b>4.5"</b>	EVO-3063S4	4.5" ENFORCER OVERLAND STAGE 4
	EVO-3063S4P	4.5" ENFORCER OVERLAND STAGE 4 PLUS
	EVO-3063S4K	4.5" ENFORCER OVERLAND STAGE 4, W/ 2.5" DIA KING RESERVOIR SHOCKS
	EVO-3063S4P	4.5" ENFORCER OVERLAND STAGE 4 PLUS, W/ 2.5" DIA KING RESERVOIR SHOCKS
<b>6.5"</b>	EVO-3065S4	6.5" ENFORCER OVERLAND STAGE 4
	EVO-3065S4P	6.5" ENFORCER OVERLAND STAGE 4 PLUS
	EVO-3065S4K	6.5" ENFORCER OVERLAND STAGE 4, W/ 2.5" DIA KING RESERVOIR SHOCKS
	EVO-3065S4PK	6.5" ENFORCER OVERLAND STAGE 4 PLUS, W/ 2.5" DIA KING RESERVOIR SHOCKS

STAGE 1 "S1", STAGE 2 "S2" STAGE 3 "S3" ALSO AVAILABLE.

REFERENCE STAGE INFORMATION ON PAGE 13.

COMPRESSION ADJUST SHOCKS AVAILABLE- SPECIAL ORDER/LEADTIME

# 2020 JEEP GLADIATOR JT COMPONENTS & UPGRADES



EVO-3028B NV2514 FRONT BOLT-ON COILOVER KIT, BLACK

COMPRESSION ADJUST COILOVERS AVAILABLE, SPECIAL ORDER/LEADTIME

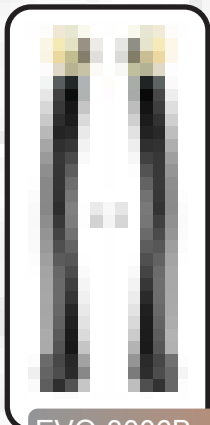

EVO-3006B FRONT LOWER ADJUSTABLE ENFORCER CONTROL ARMS

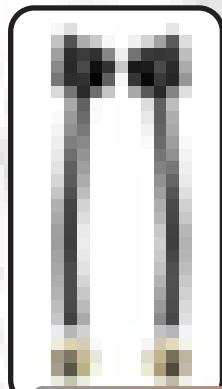

EVO-3007B FRONT UPPER ADJUSTABLE ENFORCER CONTROL ARMS

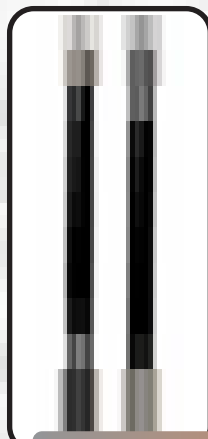

EVO-3082B REAR LOWER ADJUSTABLE ENFORCER CONTROL ARMS

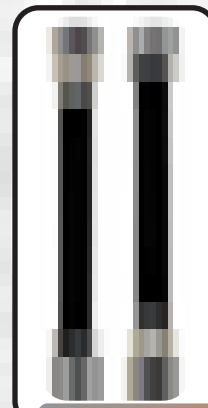

EVO-3081B REAR UPPER ADJUSTABLE ENFORCER CONTROL ARMS



EVO-3047 FRONT ADJUSTABLE TRACKBAR

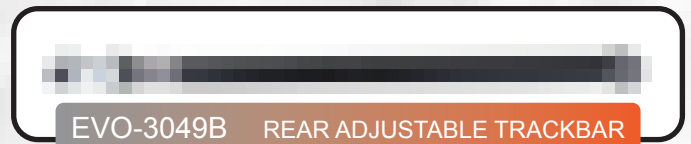

EVO-3049B REAR ADJUSTABLE TRACKBAR

# 2020 JEEP GLADIATOR JT COMPONENTS & UPGRADES

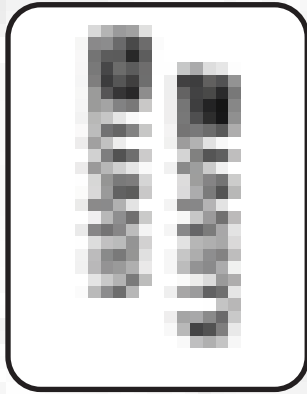
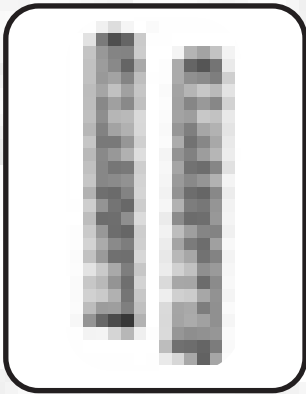

## PLUSH RIDE COILS

2.5"	EVO-3068	2.5" FRONT PLUSH RIDE COILS, PAIR
	EVO-3069	2.5" REAR PLUSH RIDE COILS, PAIR
4.5"	EVO-3076	4.5" FRONT PLUSH RIDE COILS, PAIR
	EVO-3077	4.5" REAR PLUSH RIDE COILS, PAIR
6.5"	EVO-3078	6.5" FRONT PLUSH RIDE COILS, PAIR
	EVO-3079	6.5" REAR PLUSH RIDE COILS, PAIR

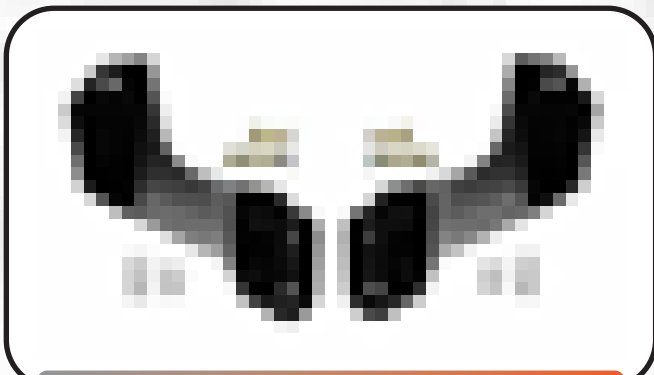

EVO-3003B OVERLAND FRONT GEOMETRY CORRECTION BRACKETS



EVO-1077 FRONT BUMPSTOP EXTENSIONS



EVO-3027B PROTEK FRONT SHOCK RELOCATION BRACKETS

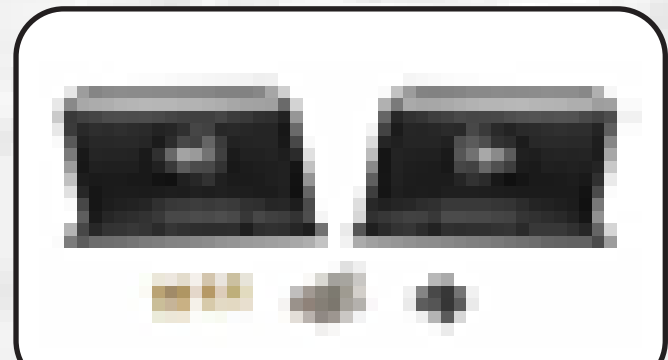
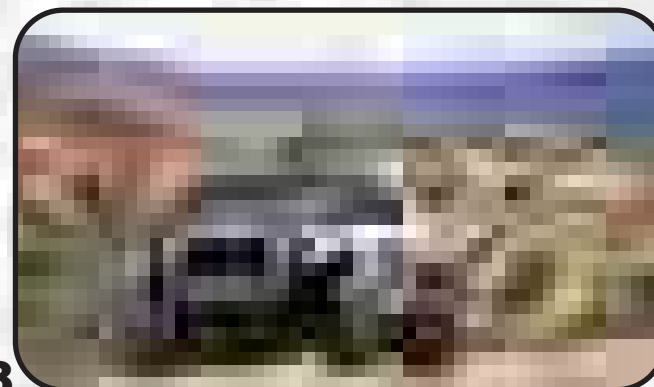

EVO-3080B-25 2.5" REAR BUMP STOP EXTENSION PAIR  
EVO-3080B-3 3.0" REAR BUMP STOP EXTENSION PAIR  
EVO-3080B-4 4.0" REAR BUMP STOP EXTENSION PAIR

# 2007-2018 JEEP WRANGLER JK/JKU SUSPENSION SYSTEMS

## JK/JKU SUSPENSION SYSTEM STAGE INFORMATION

### STAGE 1:

Includes the necessary parts to lift your jk/jku with the addition of adjustable front lower enforcer control arms. This allows for front caster adjustments.

### STAGE 2:

Includes all components of stage 2 with the addition of adjustable rear upper enforcer control arms. This allows for rear axle pinion angle adjustments

### STAGE 3:

Includes all component of stage 1 with the addition of "all 8" (front and rear upper and lower) adjustable enforcer control arms.

PRO kits are front and rear King coilover suspension systems

# 2007-2018 JEEP WRANGLER JK/JKU SUSPENSION SYSTEMS

## Double Throwdown Component Systems



EVO-1010 FRONT DOUBLE THROWDOWN



EVO-1008 REAR DOUBLE THROWDOWN

# 2007-2018 JEEP WRANGLER JK/JKU SUSPENSION SYSTEMS

## Double Throwdown Long Arm Suspension Systems

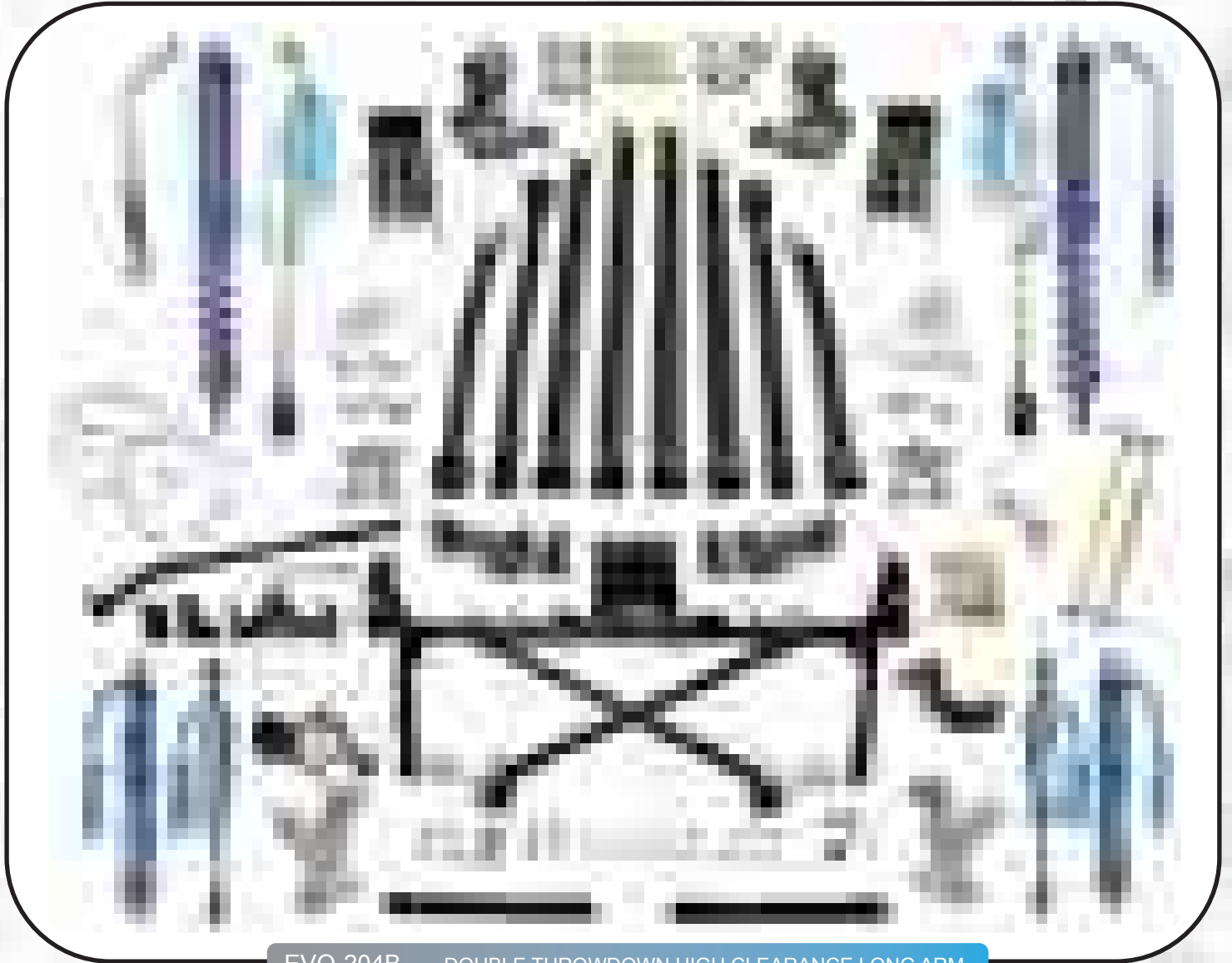

EVO-204B

DOUBLE THROWDOWN HIGH CLEARANCE LONG ARM

# 2007-2018 JEEP WRANGLER JK/JKU SUSPENSION SYSTEMS

## High Clearance PRO Coilover Long Arm Suspension Systems



EVO-202B HIGH CLEARANCE PRO COILOVER LONG ARM

COMPRESSION ADJUST COILOVERS AVAILABLE - SPECIAL ORDER/LEADTIME



# 2007-2018 JEEP WRANGLER JK/JKU SUSPENSION SYSTEMS

## Enforcer PRO Suspension Systems



### 2007-2018 JK/JKU ENFORCER PRO COILOVER

<b>STAGE 1</b>	EVO-201-1B	ENFORCER PRO STAGE 1
<b>STAGE 2</b>	EVO-201-2B	ENFORCER PRO STAGE 2
<b>STAGE 3</b>	EVO-201-3B	ENFORCER PRO STAGE 3

COMPRESSION ADJUST COILOVERS AVAILABLE- SPECIAL ORDER/LEADTIME

# 2007-2018 JEEP WRANGLER JK/JKU SUSPENSION SYSTEMS

## DOUBLE D LONG ARM SUSPENSION SYSTEMS 3" OR 4" LIFT HEIGHTS



EVO-1084-35	3" JK/JKU LONG ARM
EVO-1084-37	4" JK/JKU LONG ARM

# 2007-2018 JEEP WRANGLER JK/JKU SUSPENSION SYSTEMS

## ENFORCER SUSPENSION SYSTEMS 3" OR 4" LIFT HEIGHTS



### JK / JKU ENFORCER 3" OR 4" LIFTS

<b>STAGE 1</b>	EVO-230-35S1	3" ENFORCER STAGE 1 WITH DRAGLINK FLIP
<b>STAGE 2</b>	EVO-230-35S2	3" ENFORCER STAGE 2 WITH DRAGLINK FLIP
<b>STAGE 3</b>	EVO-230-35S3	3" ENFORCER STAGE 3 WITH DRAGLINK FLIP
<b>STAGE 1</b>	EVO-230-37S1	4" ENFORCER STAGE 1 WITH DRAGLINK FLIP
<b>STAGE 2</b>	EVO-230-37S2	4" ENFORCER STAGE 2 WITH DRAGLINK FLIP
<b>STAGE 3</b>	EVO-230-37S3	4" ENFORCER STAGE 3 WITH DRAGLINK FLIP

REFERENCE STAGE INFORMATION ON PAGE 19.

# 2007-2018 JEEP JK/JKU COMPONENTS & UPGRADES

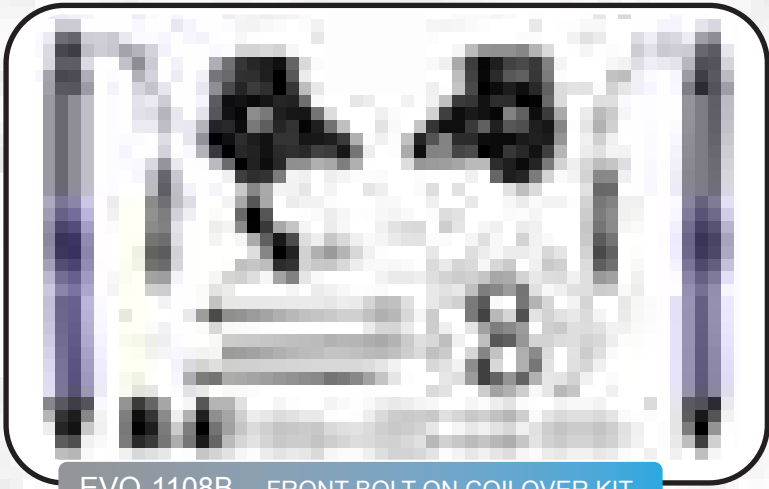

EVO-1108B FRONT BOLT ON COILOVER KIT



EVO-1109B REAR BOLT ON COILOVER KIT



EVO-1200 HIGH CLEARANCE LONG ARM UPGRADE

# 2007-2018 JEEP JK/JKU COMPONENTS & UPGRADES

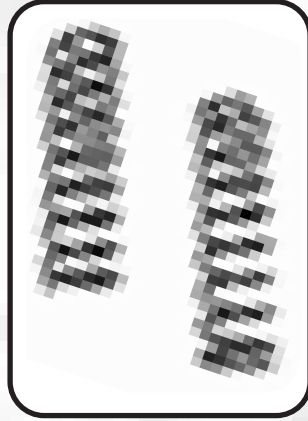
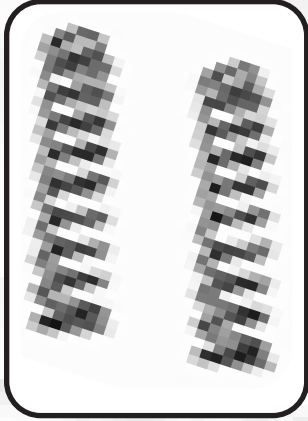

## PLUSH RIDE COILS

3"	EVO-1401	3" FRONT PLUSH RIDE SPRING PAIR
	EVO-1402	3" REAR PLUSH RIDE SPRING PAIR
4"	EVO-1061	4" FRONT PLUSH RIDE SPRING PAIR
	EVO-1062	4" REAR PLUSH RIDE SPRING PAIR

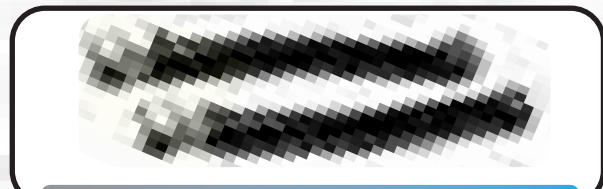

EVO-1064 FRONT LOWER ADJUSTABLE ENFORCER CONTROL ARMS

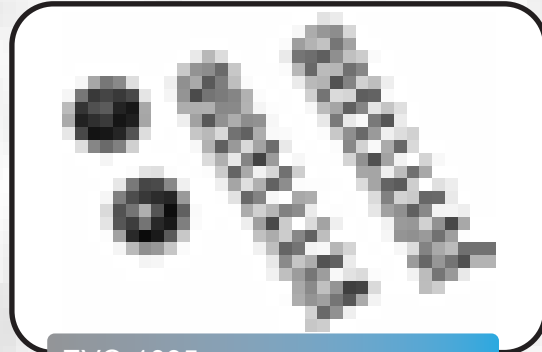

EVO-1095 HD LEVELING KIT

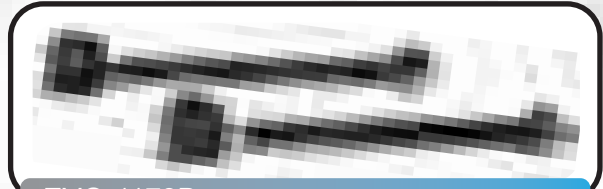

EVO-1173B FRONT UPPER ADJUSTABLE ENFORCER CONTROL ARMS



EVO-1077 FRONT BUMPSTOP EXTENSIONS

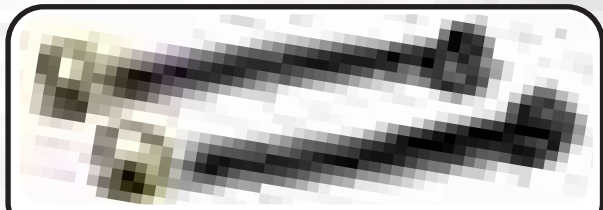

EVO-1174B REAR UPPER ADJUSTABLE ENFORCER CONTROL ARMS

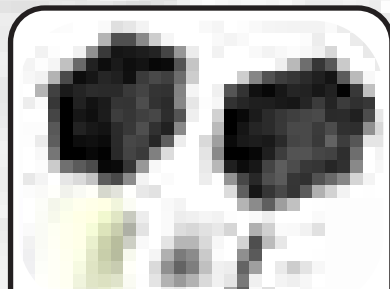

EVO-1066 REAR BUMPSTOP EXTENSIONS



EVO-1175B REAR LOWER ADJUSTABLE ENFORCER CONTROL ARMS



EVO-1071 DRAGLINK FLIP KIT

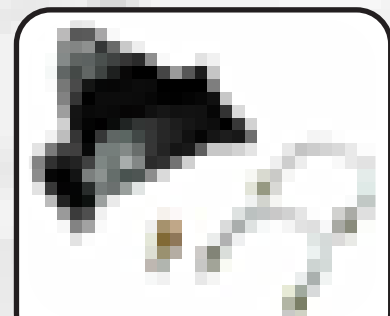

EVO-1072B REAR RCC TRACKBAR BRACKET

**2018-2019 JEEP WRANGLER JL/JLU  
2020 JEEP GLADIATOR JT  
BUMPERS , TIRE CARRIERS & ARMOR**



# 2018-2019 JEEP WRANGLER JL/JLU 2020 JEEP GLADIATOR JT BUMPERS AND TIRE CARRIERS



EVO-3057 ¼ POUNDER FRONT WINCH BUMPER, RAW STEEL  
EVO-3057B ¼ POUNDER FRONT WINCH BUMPER, BLACK

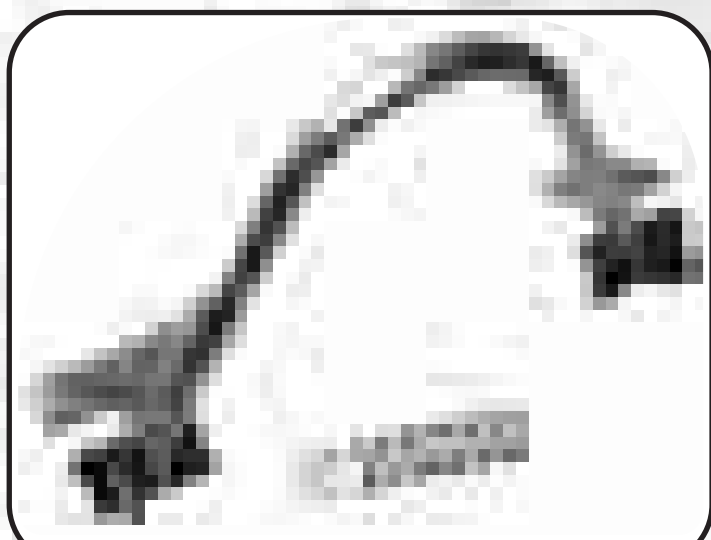

EVO-1079 REVOLUTION STINGER FOR ¼ POUNDER  
EVO-1079B REVOLUTION STINGER FOR ¼ POUNDER



EVO-3032 JL/JLU HD HINGED TIRE CARRIER, RAW  
EVO-3032B JL/JLU HD HINGED TIRE CARRIER, BLACK

# 2018-2019 JEEP WRANGLER JL/JLU 2020 JEEP GLADIATOR JT BUMPERS AND TIRE CARRIERS



EVO-3070 JEEP GLADIATOR JT CREW BOMBER ROCKERS

EVO-3071 JEEP GLADIATOR JT CREW BOMBER ROCKERS WITH ROCK SKINS



EVO-3033 JEEP WRANGLER JL/.JLU BOMBER ROCKERS

EVO-3036 JEEP WRANGLER JL/.JLU BOMBER ROCKERS WITH ROCK SKINS



# 2018-2019 JEEP WRANGLER JL/JLU 2020 JEEP GLADIATOR JT BUMPERS AND TIRE CARRIERS

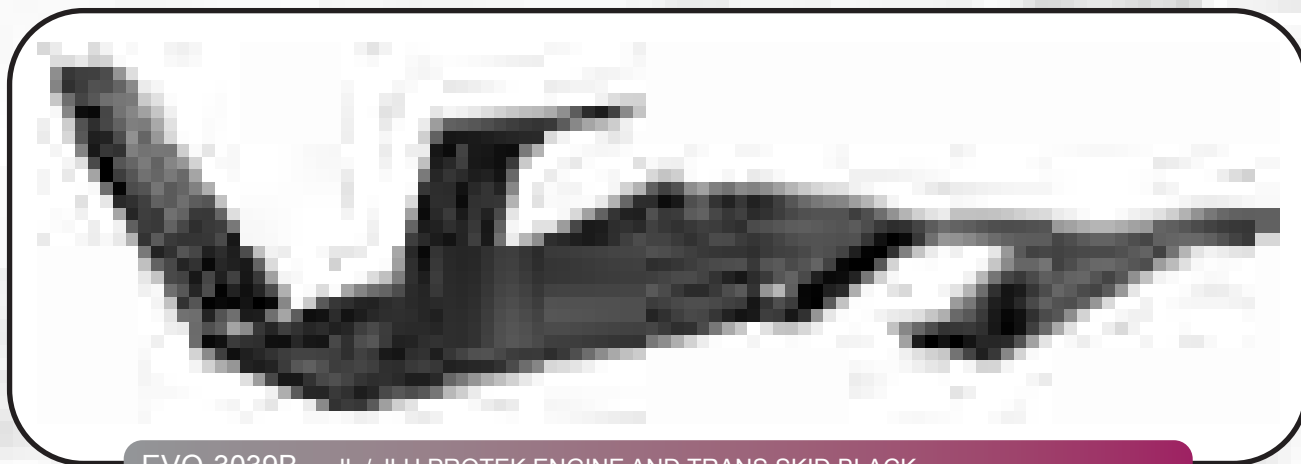

- EVO-3039B JL / JLU PROTEK ENGINE AND TRANS SKID BLACK
- EVO-3040B JL / JLU PROTEK EXHAUST LOOP SKID BLACK
- EVO-3041B JL / JLU PROTEK ENGINE, TRANS, EXHAUST LOOP SKID PACKAGE BLACK

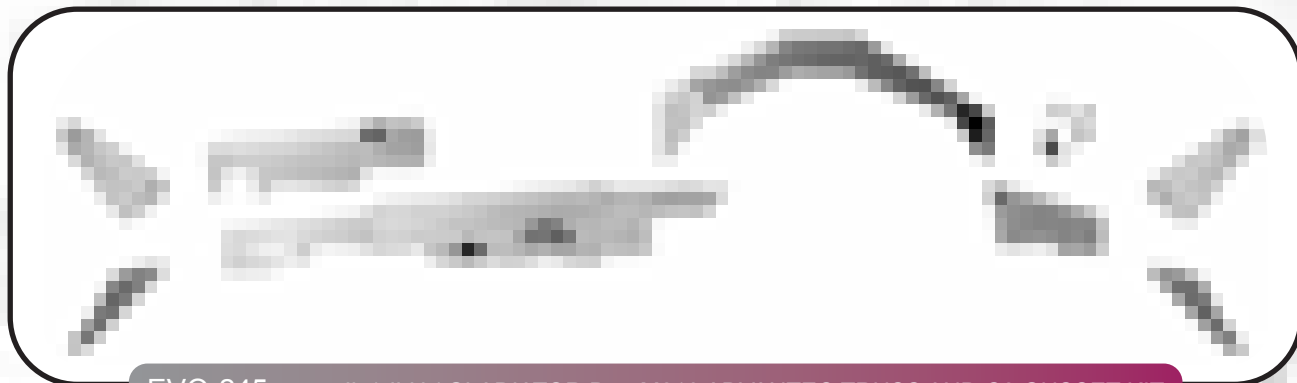

- EVO-245 JL / JLU / GLADIATOR D44 M210 ADVANTEC TRUSS AND C2 GUSSET KIT
- EVO-3050 JL / JLU / GLADIATOR D44 M210 ADVENTEC TRUSS KIT
- EVO-3051 JL / JLU / GLADIATOR ADVANTEC C2 GUSSET KIT

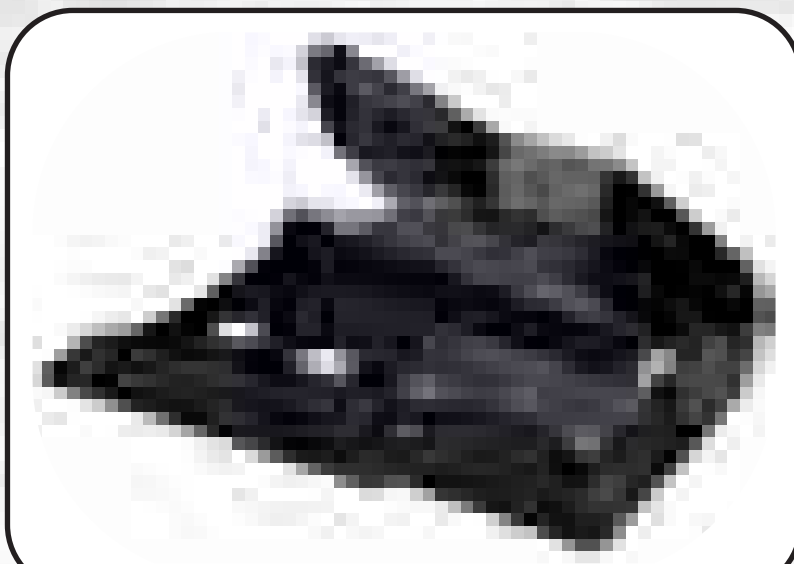

- EVO-3042B JL / JLU / GLADIATOR FRONT AXLE FAD/CAD SKID BLACK

# 2018-2019 JEEP WRANGLER JL/JLU 2020 JEEP GLADIATOR JT BUMPERS AND TIRE CARRIERS



EVO-3038 JEEP WRANGLER JL UNLIMITED TRAIL ROOF RACK, RAW  
EVO-3075AL JEEP GLADIATOR JT HALF CAB ROOF RACK, RAW



EVO-3073 MID HEIGHT ADVENTURE BED RACK



EVO-3074 CAB HEIGHT ADVENTURE BED RACK



**2007-2018 JEEP WRANGLER  
JK / JKU ACCESSORIES**

# 2007-2018 JEEP WRANGLER JK/JKU BUMPERS AND TIRE CARRIERS

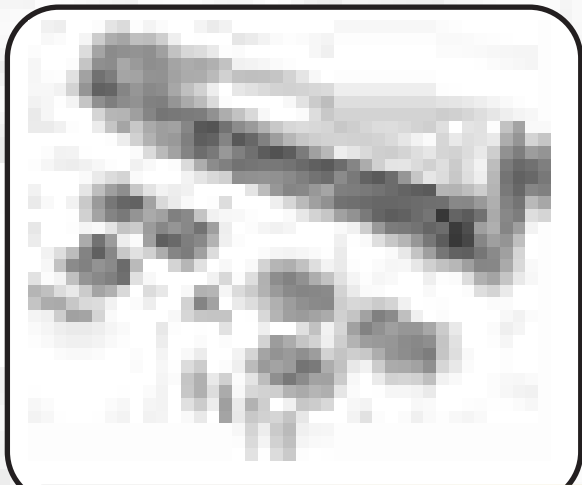

EVO-3057 1/4 POUNDER FRONT WINCH BUMPER, RAW STEEL  
EVO-3057B 1/4 POUNDER FRONT WINCH BUMPER, BLACK



EVO-1130 PRO SERIES FRONT HOOP WINCH BUMPER  
EVO-1130NH PRO SERIES FRONT WINCH BUMPER, NO HOOP

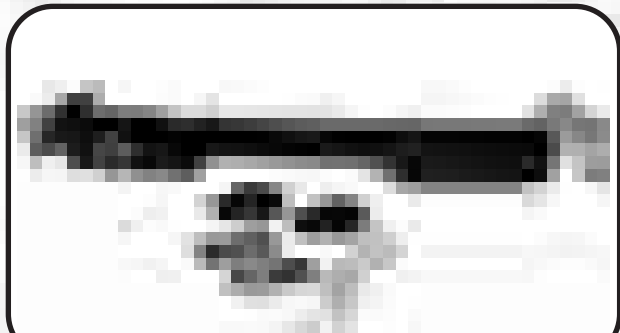

EVO-208B REAR DRING AND FACIA PACKAGE KIT BLACK  
EVO-1083B REAR BOLT ON D RING SHACKLE MOUNTS BLACK  
EVO-1111B REAR BUMPER FASCIA



EVO-1132 PRO SERIES REAR BUMPER



EVO-1079 REVOLUTION STINGER FOR 1/4 POUNDER  
EVO-1079B REVOLUTION STINGER FOR 1/4 POUNDER

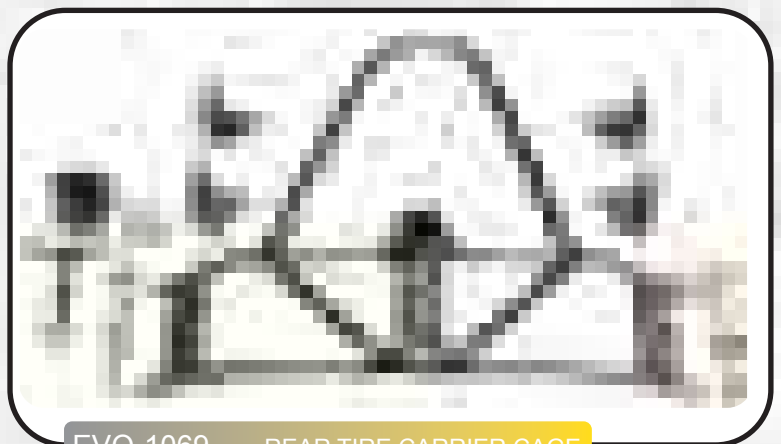

EVO-1069 REAR TIRE CARRIER CAGE

# 2007-2018 JEEP WRANGLER JK/JKU ARMOR



EVO-1048-2D ROCK SLIDERS 2 DOOR  
EVO-1048-4D ROCK SLIDERS 4 DOOR  
EVO-1048-2DSTEP ROCKSLIDER STEP 2 DOOR  
EVO-1048-4DSTEP ROCKSLIDER STEP 4 DOOR

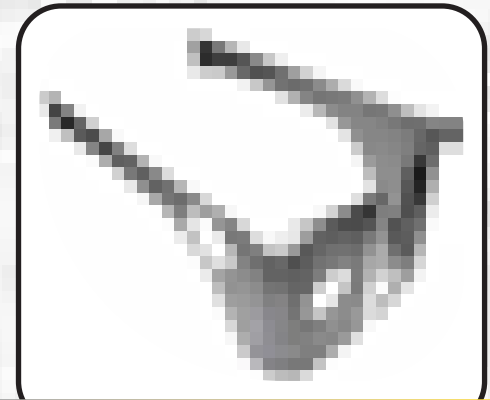

EVO-1070-2D REAR ROCK SKIN 2 DOOR  
EVO-1070-4D REAR ROCK SKIN 4 DOOR

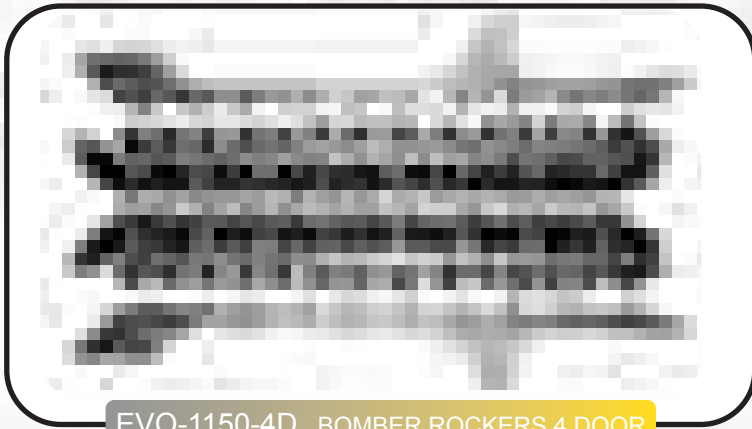

EVO-1150-4D BOMBER ROCKERS 4 DOOR



EVO-1019-4D 4 DOOR REAR BUILDER ARMOR

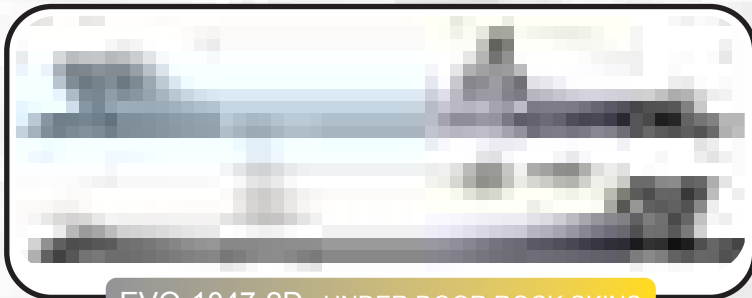

EVO-1047-2D UNDER DOOR ROCK SKINS  
EVO-1047-4D UNDER DOOR ROCK SKINS

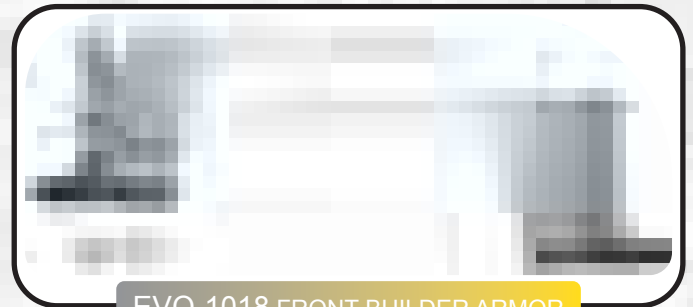

EVO-1018 FRONT BUILDER ARMOR

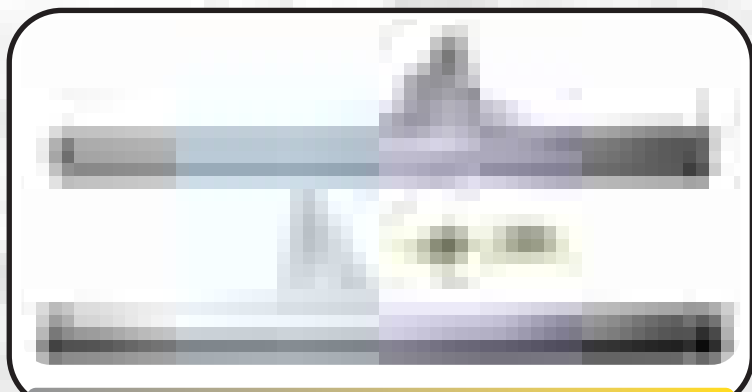

EVO-1021-4D 4 DOOR BUILDER ARMOR UNDER DOOR

# 2007-2018 JEEP WRANGLER JK/JKU PROTEK ARMOR AND SKIDS

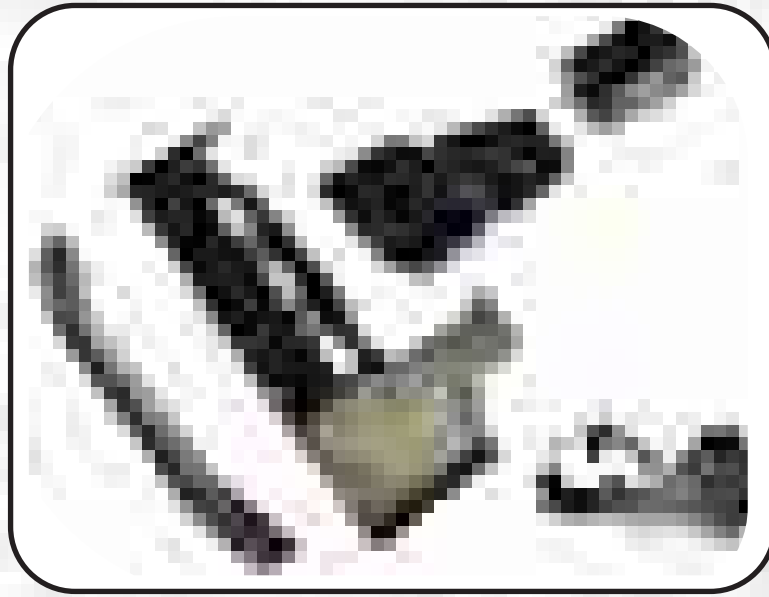

## 2007-2011 PROTEK SKID SYSTEMS

- EVO-209 3.8L PROTEK ENGINE, TRANS AND EXHAUST SKID PLATES AUTO TRANS
- EVO-210 3.8L PROTEK ENGINE, TRANS AND EXHAUST SKID PLATES MANUAL TRANS
- EVO-209X 3.8L PROTEK PACKAGE AUTO TRANS
- EVO-210X 3.8L PROTEK PACKAGE MANUAL TRANS

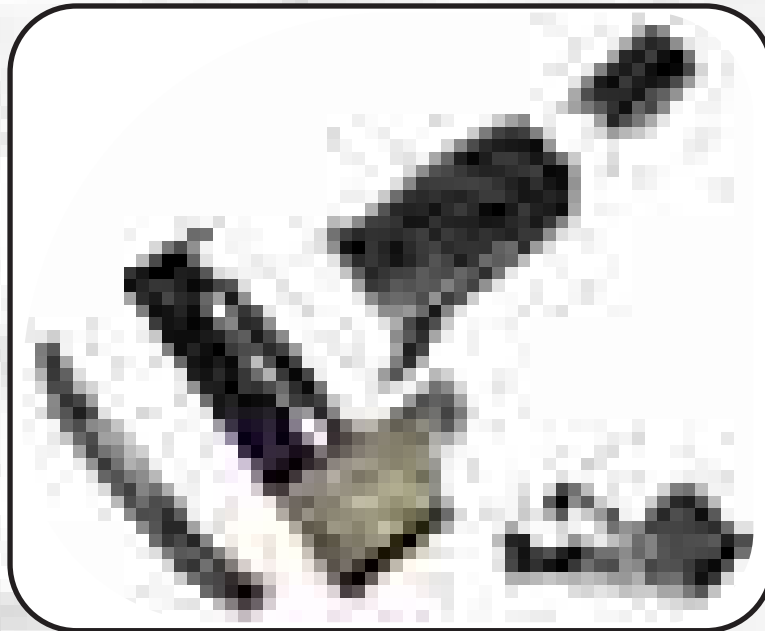

## 2011-2018 PROTEK SKID SYSTEMS

- EVO-211 3.6L PROTEK ENGINE, TRANS AND EXHAUST SKID PLATES AUTO TRANS
- EVO-212 3.6L PROTEK ENGINE, TRANS AND EXHAUST SKID PLATES MANUAL TRANS
- EVO-211X 3.6L PROTEK PACKAGE AUTO TRANS
- EVO-212X 3.6L PROTEK PACKAGE MANUAL TRANS

# 2007-2018 JEEP WRANGLER JK/JKU PROTEK ARMOR AND SKIDS



- EVO-1143-30 PROTEK FRONT AXLE TRUSS AND C2 GUSSETS, DANA 30
- EVO-1143-44 PROTEK FRONT AXLE TRUSS AND C2 GUSSETS, DANA 44
- EVO-220-30 PROTEK FRONT AXLE ARMOR TRUSS, DANA 30
- EVO-220-44 PROTEK FRONT AXLE ARMOR TRUSS, DANA 44



EVO-1138 PROTEK REAR AXLE TRUSS

# 2007-2018 JEEP WRANGLER JK / JKU ACCESSORIES



EVO-1087  
NO LIMITS MANUAL RUBICON  
SWAYBAR DISCONNECT, JK



EVO-1152  
NO LIMITS ON DEMAND SWAY  
BAR DISCONNECT



EVO-1097  
ARB AIR COMPRESSOR  
MOUNT KIT



EVO-1197  
VENTED INNER FENDERS,  
COIL SPRING SUSPENSION



EVO-1198  
VENTED INNER FENDER  
LINERS, COILOVER

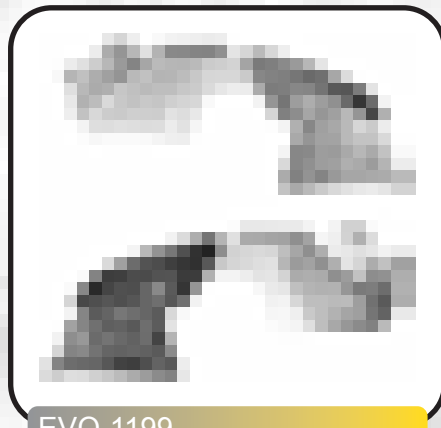

EVO-1199  
VENTED INNER FENDER LINERS,  
DOUBLE THROWDOWN

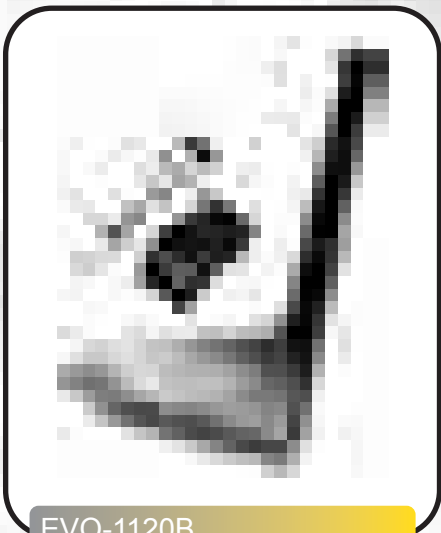

EVO-1120B  
TAILGATE JACK MOUNT BLACK

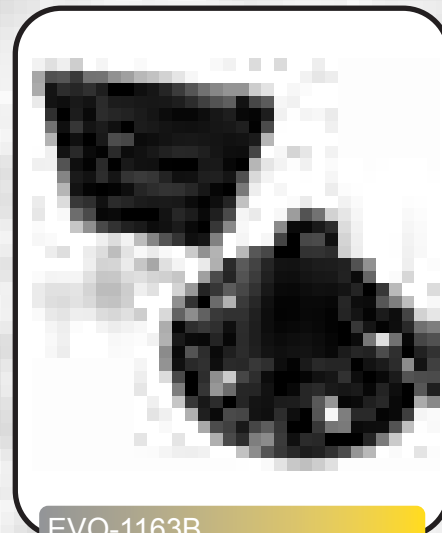

EVO-1163B  
LICENSE PLATE RELOCATE

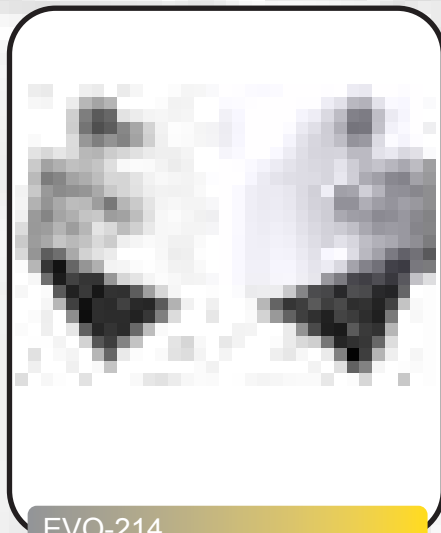

EVO-214  
MINI INNER FENDER LINERS



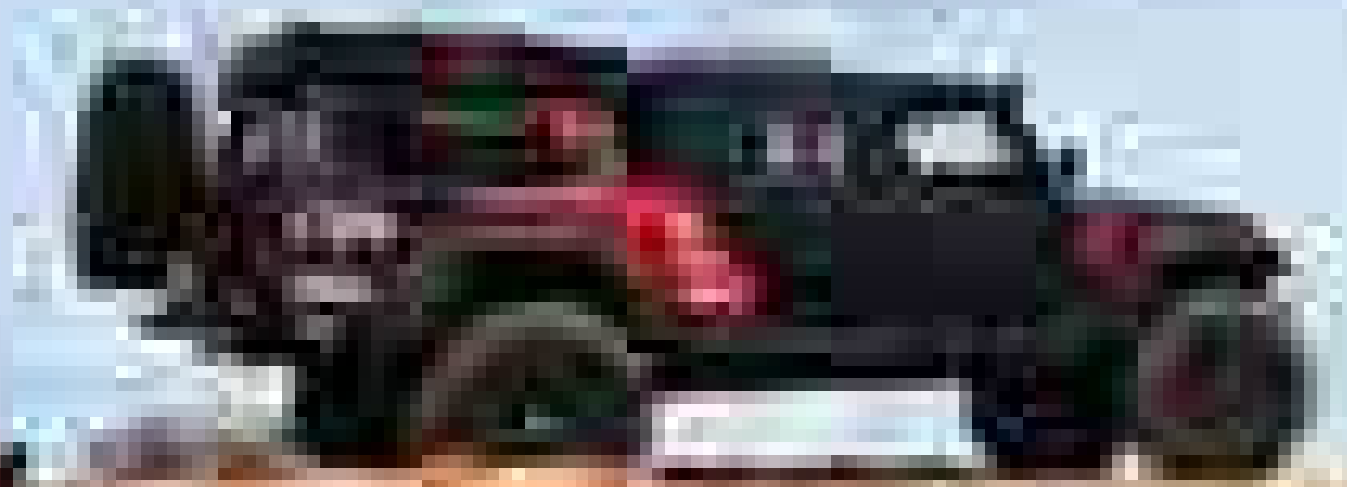



**@evo\_mfg**



**evomfg**

**WWW.EVOMFG.COM**



**MANUFACTURING**

1835 W Commonwealth Ave, Fullerton, CA 92833  
Phone: (714) 879-8913      [www.EVOMFG.com](http://www.EVOMFG.com)



## EVO-1091B EVO MFG 2012+ JK Oil Pan Skid

**PLEASE READ:** It is recommended that the oil pan be drained before install. Although it is sealed with RTV silicone and will retain to the engine block well with all bolts removed. If you decide to install EVO Skid without draining the oil, do so when oil is cold and at **YOUR OWN RISK**.

1. Recommended: follow manufacturer's instructions on draining engine oil.
2. With oil drained, using a 10mm wrench remove all bolts from oil pan. **DO NOT REMOVE PAN FROM ENGINE.**
3. Carefully install EVO Oil Pan Skid over factory oil pan. Make sure you do not hit or tap on factory pan.
4. Using the two nuts (one on driver front, one on pass rear corners) quickly hand tighten the nuts on these two studs. This will keep the pan and skid held to the engine.



5. Begin to thread **BY HAND** all factory bolts into engine through both the EVO Skid and factory oil pan holes. Make sure to thread all bolts in at least 3 full turns on each bolt before using a wrench. You are threading into aluminum and therefore they are easy to strip. **Thread first few turns by hand is a very important step.**



6. Using a 10mm wrench and/or ratchet begin to thread all bolts until they begin to touch the EVO Skid. **VERY IMPORTANT: Do not fully tighten any bolts/nuts at this stage.**
7. With all bolts just slightly touching the EVO Skid, begin to tighten all bolts in a crossing fashion to 85 **in/lbs**. The pan/skid will work its way to become tight and compressing the RTV sealant. You will need to go over all bolts in this crossing fashion a few times until all bolts are tight.
8. Double check that all bolts are tight by starting at one bolt and going around in a circle and ending at the bolt you started with. You may need to do this a couple times aswell. Importance is placed on having all bolts equally tight.
9. With all bolts tight, follow factory specifications on finishing the oil change.

**Before you start engine: MAKE SURE YOU HAVE ENGINE OIL INSTALLED.  
500 miles after install, check for any oil residue or leaks from pan.**



**EVO-1092 2012+ JK Auto Transmission Skid**

**EVO-1104 2012+ JK Manual Transmission Skid**

**Note: Requires install of EVO-1091 Oil Pan Skid for installation**



**First Column: Photos of Manual Skid**

**Second Column: Photos of Auto Skid**

1. Remove two nuts on top of transmission cross member that secure the transmission mount top plate. These are the two nuts that are on each side of the transmission that the treaded stud if facing up.
2. Manuals: With these two nuts removed, slide the EVO transmission skid over these two studs where the studs stick through the two slots cut into the EVO Skid. Thread factory nuts onto studs.
3. Autos: With these two nuts removed, using a floor jack, lift the transfer case about a ½" so the studs are just protruding past the transmission mounting plate. Now slide the EVO skid onto the stud on the driver side. Make sure stud is lined up with the hole in the EVO Skid and then carefully lower transmission/transercase with the jack. On passenger side, install the supplied passenger side mount bracket onto transmission stud, round hole on EVO Bracket at this end, big slot side on top EVO Skid. Install both factory nuts at transmission and supplied 3/8" hardware at mating between EVO Passenger skid mounting bracket and EVO Skid.
4. Using the supplied 7/16" Hardware, install front of skid to oil pan. Transmission skid should be on the lower side of the two tabs on back of the EVO oil pan skid.
5. Tighten all bolts: Factory bolts 37 ft/lbs, 7/16" bolts to 60 ft/lbs, 3/8" bolt to 40 ft/lbs



## EVO-1093

### JK Transmission Crossmember and Exhaust Skid



1. Remove factory transference skid (4 bolts: 2 on the center of the transmission cross member, 1 on gas tank, 1 on driver side frame)
2. Some JKs have a skid plate/bar on the front of the transmission cross member, remove this as well. Save Hardware, Factory bar you will not reuse.
3. Remove two bolts on passenger side that attach the gas tank skid to the transmission cross member
4. Remove only the nut on the driver side lower front control arm at the control arm mount at the frame. Leave bolt installed.
5. Carefully lift EVO Transmission Crossmember/Exhaust Skid up. Pay attention to round tab on driver side with a hole in it. This hole needs to connect with factory lower control arm bolt. Using Factory hardware, thread the two bolts a couple of turn's by hand that hold the gas tank skid to the transmission crossmember. Overlapping the EVO Skid on top of the skid for the gas tank. (Factory gas tank skid portion will be sandwiched between the transmission crossmember and EVO Skid).
6. Thread a couple of turns by hand the nut back onto factory lower control arm sandwiching the EVO Skid against the frame. Thread the center bolt into transmission crossmember.
7. If your JK came with a skid/bar forward of the transmission crossmember use this hardware. If not use supplied EVO hardware. Thread a couple of turns the two forward most holes on the bottom of the frame on both the driver and passenger sides through the EVO Skid.
8. Reinstall the factory transference skid over the EVO Skid at the transmission crossmember and factory location at the gas tank and driver side frame will factory hardware. Tighten all Hardware: Lower Control Arm Bolt 125 ft/lbs, All others 80 ft/lbs





## **EVO-S102**

### **Front and Rear Bolt on Coilover HD Spring Set**



#### **Notes:**

**12" spring replaces front lower spring.**

**10" spring replaces your rear upper spring.**

### **12" Spring replaces the front lower spring on your EVO MFG Front Bolt on Coilovers**

- Raise front of vehicle off the ground so the shocks are fully extended
- Remove lower shock bolt
- Turn the blue coil adjustment nut all the way to the top of the shock
- Lift up on the coil plate and slide the coil plate off of the shock shaft using the slot provided on the coil plate. ( Note: be careful as this will allow the springs and coil slider to drop freely from the shock )
- Remove lower spring
- Install new 12" HD Spring
- Reinstall coil plate on shock
- Install lower shock bolt and torque to spec.
- Lower vehicle on ground
- Adjust coil adjustment nut and set desired ride height (Note: Passenger side will have roughly  $\frac{3}{4}$ " more adjustment than driver side.)

### **10" Spring replaces the rear upper spring on your EVO MFG Rear Bolt on Coilovers**

- Raise rear of the vehicle off the ground so the shocks are fully extended
- Remove lower shock bolt
- Turn the blue coil adjustment nut all the way to the top of the shock
- Lift up on the coil plate and slide the coil plate off of the shock shaft using the slot provided on the coil plate. ( Note: be careful as this will allow the springs and coil slider to drop freely from the shock )
- Remove lower spring
- Remove coil slider
- Remove upper spring
- Install new 10" HD Spring
- Reinstall coil slider
- Reinstall lower spring
- Reinstall coil plate on shock
- Install lower shock bolt and torque to spec.
- Lower vehicle on ground
- Adjust coil adjustment nut and set desired ride height (Note: Passenger side will have roughly  $\frac{3}{4}$ " more adjustment than driver side.)



## 2018 + Jeep Wrangler JL 2.5 Front Shocks

King Shocks 12472 Edison Way Garden Grove, CA 92841  
714-530-8701 [www.kingshocks.com](http://www.kingshocks.com)

### Front Parts List:

- 2 – 2.5 Front Shocks (25001-373 0-2.5" Lift OR → 25001-375 3-5" Lift)
- 2 – Front Reservoir Brackets (25044-021L/22R)
- 2 – Res Brkt Nut Plate (25044-023)
- 2 – Reservoir Clamp – 3 Hole (21042-003)
- 4 – 1/4 X 1" FHCS (CB5501)
- 2 – 1/4 X 1" SHCS (CB1501)
- 2 – 1/4 X 1" Bolts (CB4502)
- 2 – 1/4" SAE Washers (CW1501)

### Tools Required:

- Floor Jack/Jack Stands
- Metric Wrench/Socket Set
- Standard Wrench/Socket Set



**FRONT:** With the vehicle on level ground, set the emergency brake and block the rear tires. Using a floor jack, raise the front end and support the frame rails with jack stands for safety. Remove tires. **NOTE: Never work under an unsupported vehicle.**

1. Keep a jack under the axle while removing and installing shocks; (**For Non-Rubicon models:** shocks have internal rebound spring... you will need to jack the axle up a couple inches to take the tension off of the shock while removing lower bolt.) First remove the lower nut using an 18mm socket and wrench. Jack the axle up and pull down on shock until you can pull the bolt out by hand, Do Not attempt to run the bolt out with an impact without the axle being supported, you will damage the threads and the axle will drop abruptly when the bolt comes out.

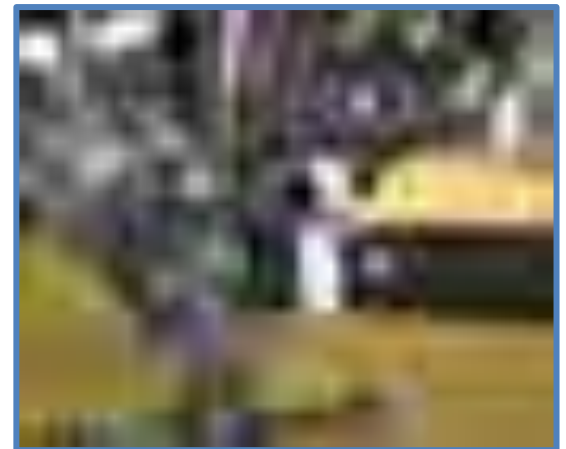
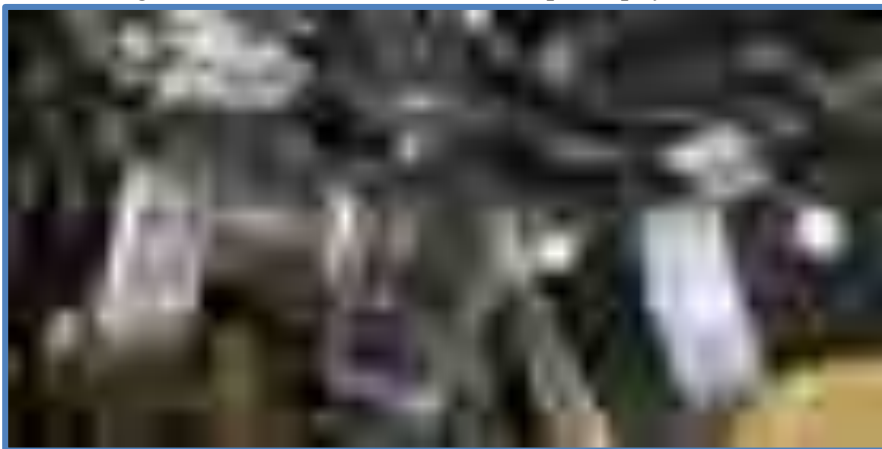

**IMPORTANT:** Read all instructions thoroughly from start to finish before beginning the install. Check parts list and make sure all parts are included in the kit. If the instructions are not properly followed severe frame, driveline and/or suspension damage may result. Check for frame and suspension damage prior to installation.

This kit does not require welding. Do not weld on any component. Welding may void the warranty and/or cause the product to fail. If any parts are missing, or for tech assistance; Contact King Off Road Racing Shocks: 714-530-8701 Most important after the install, Feel the difference and have fun.



## 2018 + Jeep Wrangler JL 2.5 Front Shocks

King Shocks 12472 Edison Way Garden Grove, CA 92841  
714-530-8701 [www.kingshocks.com](http://www.kingshocks.com)

2. Remove the upper bolt using an 18mm wrench or socket and remove shock.

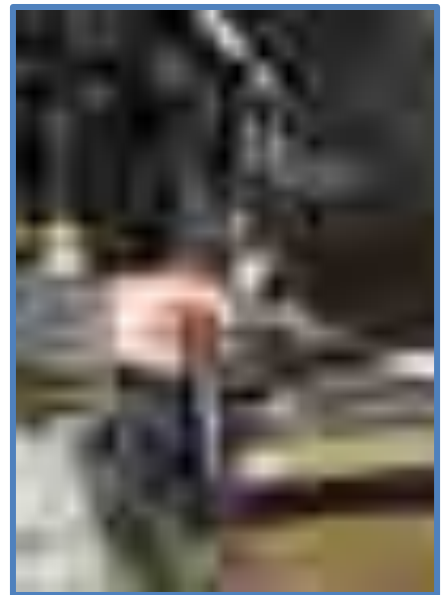
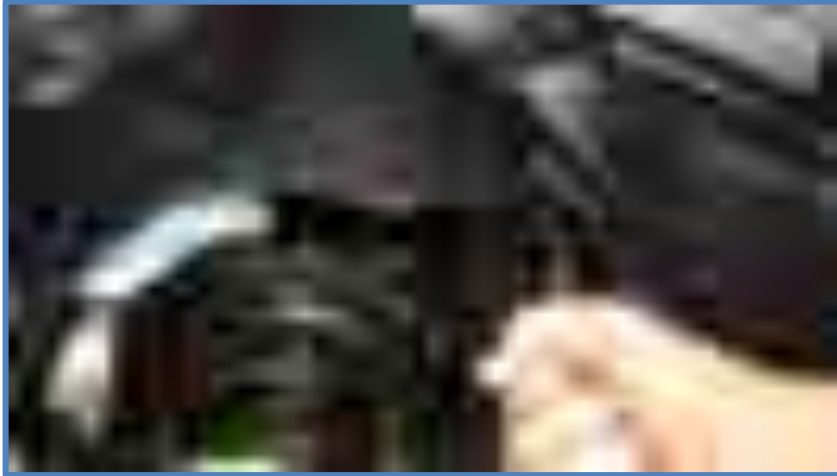

3. Remove the brake line bracket bolt using a 10mm wrench or socket.

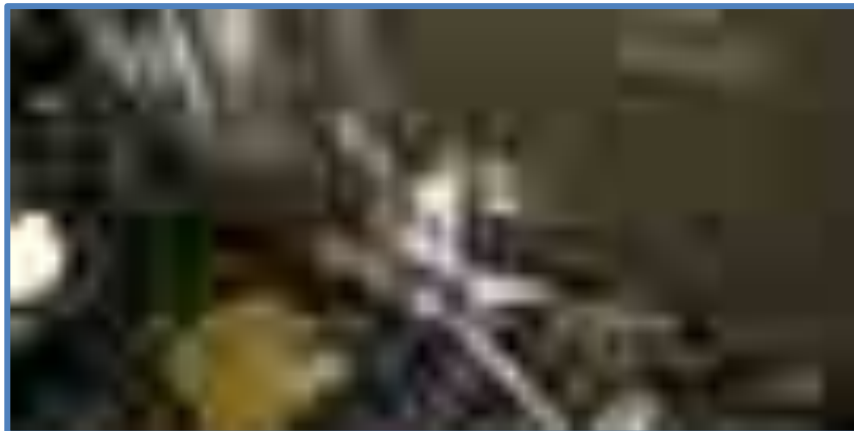

**IMPORTANT:** Read all instructions thoroughly from start to finish before beginning the install. Check parts list and make sure all parts are included in the kit. If the instructions are not properly followed severe frame, driveline and/or suspension damage may result. Check for frame and suspension damage prior to installation.

This kit does not require welding. Do not weld on any component. Welding may void the warranty and/or cause the product to fail. If any parts are missing, or for tech assistance; Contact King Off Road Racing Shocks: 714-530-8701 Most important after the install, Feel the difference and have fun.



## 2018 + Jeep Wrangler JL 2.5 Front Shocks

King Shocks 12472 Edison Way Garden Grove, CA 92841  
714-530-8701 [www.kingshocks.com](http://www.kingshocks.com)

4. On the left side of the vehicle you will need to pry the plastic push pin holding the differential breather tube from the frame. Using a screw driver or special prying tool, carefully remove the plastic push pin from the frame. Try not to damage this piece as you will reinsert it into the reservoir bracket after it's installed.

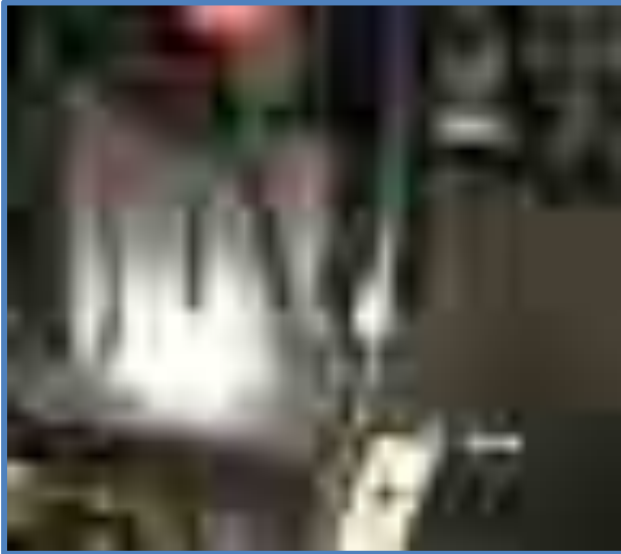

5. **Installing reservoir brackets** – First bolt the clamp to the reservoir bracket using the provided 1/4 X 1" FHCS (CB5501) using a 5/32 Allen wrench. Be aware the brackets are side specific. Photos show the **RIGHT SIDE**. See below for proper orientation.

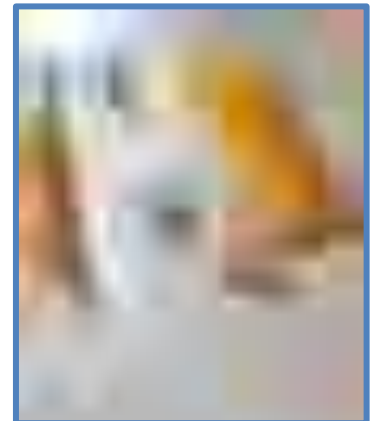
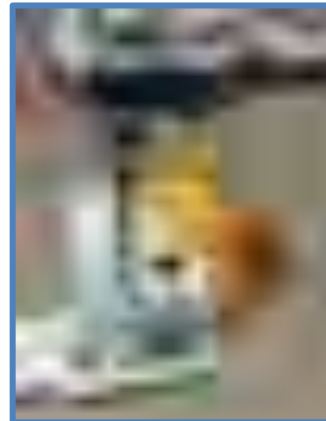
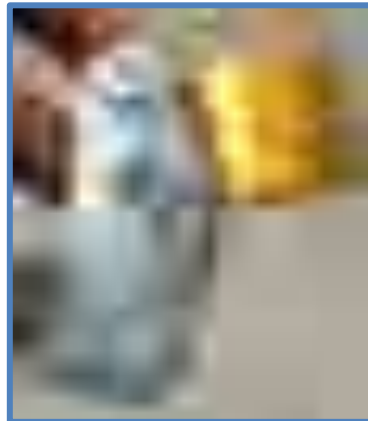
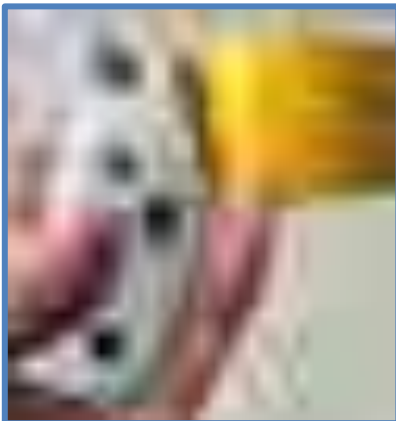

**IMPORTANT:** Read all instructions thoroughly from start to finish before beginning the install. Check parts list and make sure all parts are included in the kit. If the instructions are not properly followed severe frame, driveline and/or suspension damage may result. Check for frame and suspension damage prior to installation.

This kit does not require welding. Do not weld on any component. Welding may void the warranty and/or cause the product to fail. If any parts are missing, or for tech assistance; Contact King Off Road Racing Shocks: 714-530-8701 Most important after the install, Feel the difference and have fun.



## 2018 + Jeep Wrangler JL 2.5 Front Shocks

King Shocks 12472 Edison Way Garden Grove, CA 92841  
714-530-8701 [www.kingshocks.com](http://www.kingshocks.com)

6. Place the reservoir bracket on the frame underneath the brake line bracket. Use the factory bolt to install the brake line bracket over the reservoir bracket. Install the bolt but leave loose for now. Insert the plastic push pin for the diff. breather tube into the hole provided in the reservoir bracket.

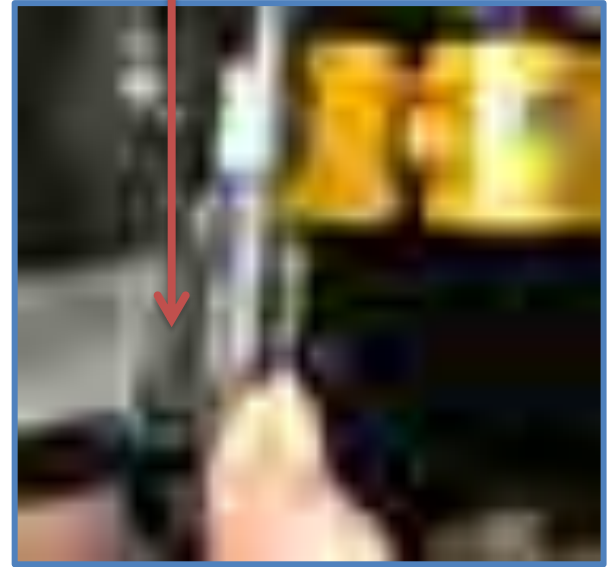
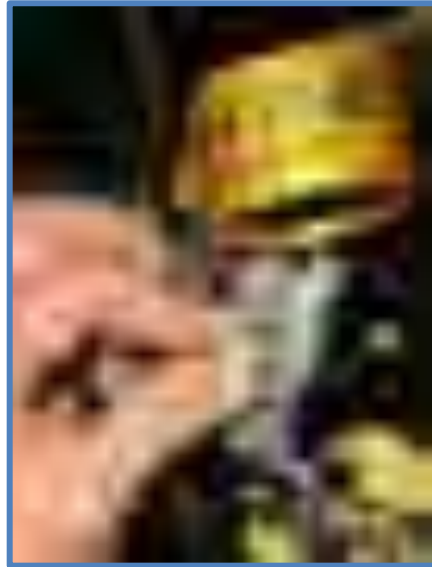
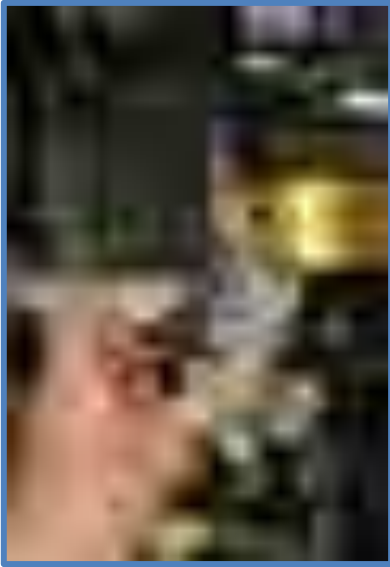

7. Now use the bent threaded nut plate included in the kit to secure the reservoir bracket on the other end. Place the nut plate in the large hole in the frame and line up with the hole in the reservoir bracket. Use the 1/4 X 1" bolts (CB4502 with washer CW1501) to thread into the nut plate.



**IMPORTANT:** Read all instructions thoroughly from start to finish before beginning the install. Check parts list and make sure all parts are included in the kit. If the instructions are not properly followed severe frame, driveline and/or suspension damage may result. Check for frame and suspension damage prior to installation.

This kit does not require welding. Do not weld on any component. Welding may void the warranty and/or cause the product to fail. If any parts are missing, or for tech assistance; Contact King Off Road Racing Shocks: 714-530-8701 Most important after the install, Feel the difference and have fun.



## 2018 + Jeep Wrangler JL 2.5 Front Shocks

King Shocks 12472 Edison Way Garden Grove, CA 92841  
714-530-8701 [www.kingshocks.com](http://www.kingshocks.com)

8. Tighten the factory brake line bolt using a 10mm wrench or socket. Tighten the 1/4" bolt using a 7/16 wrench or socket. Be very careful not to over tighten these bolts.



9. **Installing Shocks** – Be aware the shocks are side specific, make sure you have the proper shock for the side you are working on (photos below show LEFT SIDE). Begin placing the shock into position on the vehicle while inserting the reservoir into the clamp. Place the end cap into the upper mount, install the factory bolt and tighten to 60 ft-lbs.



**IMPORTANT:** Read all instructions thoroughly from start to finish before beginning the install. Check parts list and make sure all parts are included in the kit. If the instructions are not properly followed severe frame, driveline and/or suspension damage may result. Check for frame and suspension damage prior to installation.

This kit does not require welding. Do not weld on any component. Welding may void the warranty and/or cause the product to fail. If any parts are missing, or for tech assistance; Contact King Off Road Racing Shocks: 714-530-8701 Most important after the install, Feel the difference and have fun.



## 2018 + Jeep Wrangler JL 2.5 Front Shocks

King Shocks 12472 Edison Way Garden Grove, CA 92841  
714-530-8701 [www.kingshocks.com](http://www.kingshocks.com)

10. Rotate the reservoir in the clamp so the hose is tight to the frame. Install the 1/4" X 1" SHCS (CB1501) in the clamp and tighten until the reservoir is secure.



11. Place the rod end into the lower mount, install the factory bolt and tighten to 60 ft-lbs.



**IMPORTANT:** Read all instructions thoroughly from start to finish before beginning the install. Check parts list and make sure all parts are included in the kit. If the instructions are not properly followed severe frame, driveline and/or suspension damage may result. Check for frame and suspension damage prior to installation.

This kit does not require welding. Do not weld on any component. Welding may void the warranty and/or cause the product to fail. If any parts are missing, or for tech assistance; Contact King Off Road Racing Shocks: 714-530-8701 Most important after the install, Feel the difference and have fun.



**2018 + Jeep Wrangler JL 2.5 Front Shocks**

King Shocks 12472 Edison Way Garden Grove, CA 92841  
714-530-8701 [www.kingshocks.com](http://www.kingshocks.com)

**Final install should look similar to photo below****DOUBLE CHECK ALL HARDWARE:**

Make sure everything is installed correctly and all hardware is tight before reinstalling tires. Install tires, remove jack stands and lower vehicle to the ground. Recheck all hardware and lug nuts after 100 miles and periodically after that as part of routine maintenance.

**IMPORTANT:** Read all instructions thoroughly from start to finish before beginning the install. Check parts list and make sure all parts are included in the kit. If the instructions are not properly followed severe frame, driveline and/or suspension damage may result. Check for frame and suspension damage prior to installation.

This kit does not require welding. Do not weld on any component. Welding may void the warranty and/or cause the product to fail. If any parts are missing, or for tech assistance; Contact King Off Road Racing Shocks: 714-530-8701 Most important after the install, Feel the difference and have fun.



## 2018 + Jeep Wrangler JL 2.5 Rear Shocks

King Shocks 12472 Edison Way Garden Grove, CA 92841  
714-530-8701 [www.kingshocks.com](http://www.kingshocks.com)

### Rear Parts List:

2 – 2.5 Rear Shocks (25001-374 0-2.5" Lift) OR  
2 – 2.5 Rear Shocks (25001-376 3-5" Lift) ←

### Tools Required:

Floor Jack/Jack Stands  
Metric Wrench/Socket Set  
Standard Wrench/Socket Set



**REAR:** With the vehicle on level ground, block the front tires. Using a floor jack, raise the rear end and support the frame rails with jack stands for safety. Remove tires. **NOTE: Never work under an unsupported vehicle.**

1. First remove the plastic cover behind the rear shock. Use an 8mm wrench or socket to remove the three screws and remove the plastic piece.

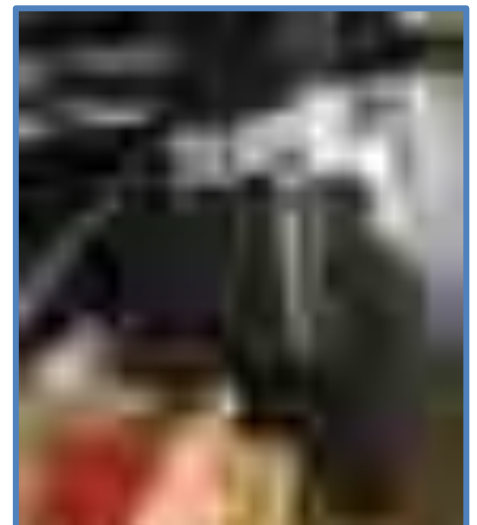
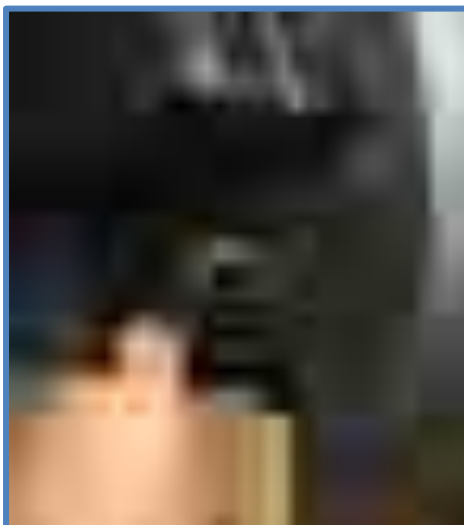

**IMPORTANT:** Read all instructions thoroughly from start to finish before beginning the install. Check parts list and make sure all parts are included in the kit. If the instructions are not properly followed severe frame, driveline and/or suspension damage may result. Check for frame and suspension damage prior to installation.

This kit does not require welding. Do not weld on any component. Welding may void the warranty and/or cause the product to fail. If any parts are missing, or for tech assistance; Contact King Off Road Racing Shocks: 714-530-8701 Most important after the install, Feel the difference and have fun.



## 2018 + Jeep Wrangler JL 2.5 Rear Shocks

King Shocks 12472 Edison Way Garden Grove, CA 92841  
714-530-8701 [www.kingshocks.com](http://www.kingshocks.com)

2. Keep a jack under the axle while removing and installing shocks; (**For Non-Rubicon models:** shocks have internal rebound spring... you will need to jack the axle up a couple inches to take the tension off of the shock while removing lower bolt.) First remove the lower nut using an 18mm socket and wrench. Jack the axle up and pull down on shock until you can pull the bolt out by hand, Do Not attempt to run the bolt out with an impact without the axle being supported, you will damage the threads and the axle will drop abruptly when the bolt comes out.



3. Remove upper bolt using an 18mm wrench or socket and remove shock.



**IMPORTANT:** Read all instructions thoroughly from start to finish before beginning the install. Check parts list and make sure all parts are included in the kit. If the instructions are not properly followed severe frame, driveline and/or suspension damage may result. Check for frame and suspension damage prior to installation.

This kit does not require welding. Do not weld on any component. Welding may void the warranty and/or cause the product to fail. If any parts are missing, or for tech assistance; Contact King Off Road Racing Shocks: 714-530-8701 Most important after the install, Feel the difference and have fun.

**2018 + Jeep Wrangler JL 2.5 Rear Shocks**

King Shocks 12472 Edison Way Garden Grove, CA 92841  
714-530-8701 [www.kingshocks.com](http://www.kingshocks.com)

4. Install King Shocks so that the reservoir is facing towards the rear of the vehicle. Place the end cap into the upper mount and install the factory bolt and tighten to 60 ft-lbs. Place the rod end into the lower mount, install the factory bolt and nut and tighten to 60 ft-lbs.



**IMPORTANT:** Read all instructions thoroughly from start to finish before beginning the install. Check parts list and make sure all parts are included in the kit. If the instructions are not properly followed severe frame, driveline and/or suspension damage may result. Check for frame and suspension damage prior to installation.

This kit does not require welding. Do not weld on any component. Welding may void the warranty and/or cause the product to fail. If any parts are missing, or for tech assistance; Contact King Off Road Racing Shocks: 714-530-8701 Most important after the install, Feel the difference and have fun.



## 2018 + Jeep Wrangler JL 2.5 Rear Shocks

King Shocks 12472 Edison Way Garden Grove, CA 92841  
714-530-8701 [www.kingshocks.com](http://www.kingshocks.com)

5. You will need to trim the plastic covers if you are reinstalling them. Cut out the section shown in the pictures below and test fit. Trim plastic until it is not touching the shock and reinstall using the factory screws.

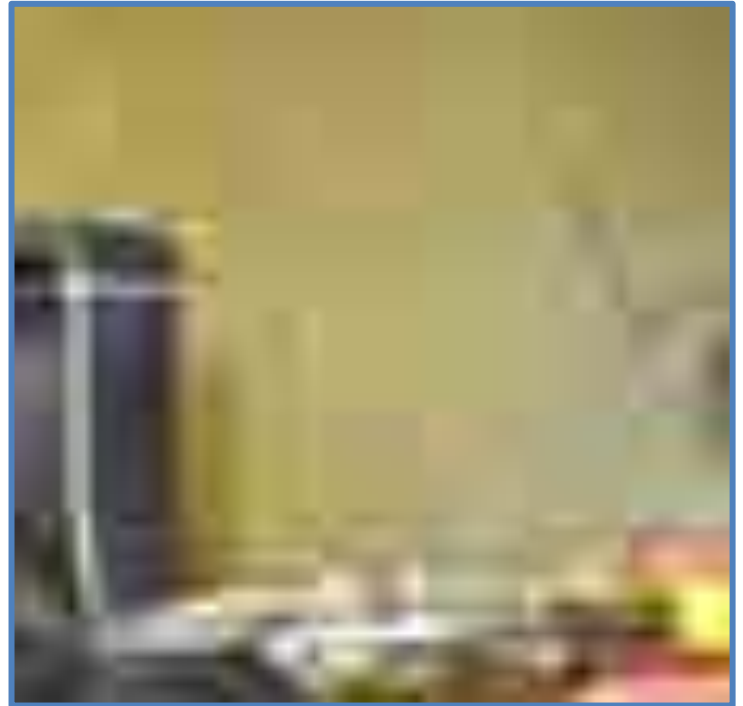

**IMPORTANT:** Read all instructions thoroughly from start to finish before beginning the install. Check parts list and make sure all parts are included in the kit. If the instructions are not properly followed severe frame, driveline and/or suspension damage may result. Check for frame and suspension damage prior to installation.

This kit does not require welding. Do not weld on any component. Welding may void the warranty and/or cause the product to fail. If any parts are missing, or for tech assistance; Contact King Off Road Racing Shocks: 714-530-8701 Most important after the install, Feel the difference and have fun.



## 2018 + Jeep Wrangler JL 2.5 Rear Shocks

King Shocks 12472 Edison Way Garden Grove, CA 92841  
714-530-8701 [www.kingshocks.com](http://www.kingshocks.com)



**DOUBLE CHECK ALL HARDWARE:** Make sure everything is installed correctly and all hardware is tight before reinstalling tires. Install tires; remove jack stands and lower vehicle to the ground. Recheck all hardware and lug nuts after 100 miles and periodically after that as part of routine maintenance.

**IMPORTANT:** Read all instructions thoroughly from start to finish before beginning the install. Check parts list and make sure all parts are included in the kit. If the instructions are not properly followed severe frame, driveline and/or suspension damage may result. Check for frame and suspension damage prior to installation.

This kit does not require welding. Do not weld on any component. Welding may void the warranty and/or cause the product to fail. If any parts are missing, or for tech assistance; Contact King Off Road Racing Shocks: 714-530-8701 Most important after the install, Feel the difference and have fun.